

Annual Energy Audit Report

FY 2023-24



**Thrissur Corporation Electricity Department
(TCED)**

Reg No. DIS0070KL

Thrissur, Kerala.

Prepared by



Centre for Energy Environment & Productivity

1039, 26th Street, H Block, Ponni Colony,

Anna Nagar, Chennai 600040

Ph: +91 9444882553 / 8668115663 E-Mail: ceepnagesh@gmail.com

July 2024

ACKNOWLEDGEMENTS

Bureau of Energy Efficiency (BEE) through its extraordinary gazette notification on 06th October 2021 made the regulation: Manner and Intervals for Conduct of Energy Audit in electricity distribution companies) Regulations, 2021. Through this every electricity distribution company shall conduct an annual energy audit for every financial year and submit the annual energy audit report to the Bureau and respective State Designated Agency (Energy Management Centre, Govt of Kerala) within a period of four months from the expiry of the relevant financial year.

Centre for Energy Environment and Productivity (CEEP) places on record its sincere thanks to M/s Thrissur Corporation Electricity Department (TCED) for entrusting the task of conducting Energy audit for its DISCOM during July 2024.

We would also like to thank the following officials of M/s Thrissur Corporation Electricity Department (TCED), Thrissur District-Kerala - 680001. for their proactive support and courtesy extended to the AEC team during the study and all other staff, especially the Assistant Engineers and sub staffs of each section, for their cooperation and support given during the whole process.

Mr. Jose T Simon

Electrical Engineer

Ms. Jayasree V S

Finance Manager

Mr. Nikhil B

Assistant engineer/Energy Auditor

Ms. Deepa S

IT Manager

12-08-2024

J Nagesh Kumar

Director/ AEA 0133

Centre for Energy Environment & Productivity

1039, 26th Street, H Block, Ponni Colony,

Anna Nagar, Chennai 600040

tallkumar@gmail.com, ceepnagesh@gmail.com

Centre for Energy, Environment and Productivity
Plot No. 1039, 26th Street, H-Block,
Ponni Colony, Anna Nagar, Chennai - 600 040.
PH : 044 2616 3483, 9444882553

ENERGY AUDIT TEAM

Table 1: Energy audit team

Sr No	Name	Qualification	EM/EA/AEA/ Registration No	Experience (In Years)
Team Leader				
1	Mr. J Nagesh Kumar	• Accredited Energy Auditor	AEA-0133	30
Team Members				
2	Mr. Sunil Kumar V K	• Certified Energy Auditor • Sector Expert	EA - 3642	32
3	Mr. Ashok K M P	• Certified Energy Auditor • M. E. (Energy Engineering)	EA- 34760/22	09
4	Ms. Della David	• Certified Energy Auditor • M. Tech (Power electronics)	EA -34867/22	15
5	Ms. Keerthana K	• Project Engineer	NIL	3
6	Ms. Neema Joy P	• Project Engineer	NIL	2

TABLE OF CONTENTS

ACKNOWLEDGEMENTS.....	2
ENERGY AUDIT TEAM.....	3
TABLE OF CONTENTS.....	4
LIST OF TABLES.....	5
LIST OF FIGURES.....	8
EXECUTIVE SUMMARY.....	9
1. PERFORMANCE SUMMARY.....	9
2. ENERGY CONSERVATION MEASURES SUMMARY.....	9
3. GENERAL OBSERVATIONS AND SUGGESTIONS.....	10
4. COMPLIANCE TO RENEWABLE PURCHASE OBLIGATIONS.....	10
BACKGROUND.....	11
1. ABOUT BEE.....	11
2. EXTANT OF REGULATIONS - DISCOM.....	11
3. PURPOSE OF AUDIT AND ACCOUNTING REPORT.....	12
4. PERIOD OF ENERGY AUDIT AND ACCOUNTING.....	12
5. PROGRESS IN COMPLIANCE TO PREREQUISITES TO ENERGY ACCOUNTING.....	12
DISCOM INTRODUCTION AND OVERVIEW.....	13
1. NAME AND ADDRESS OF DESIGNATED CONSUMER.....	13
2. ENERGY AUDIT CELL.....	13
3. SUMMARY PROFILE OF DISCOM – FORM-1.....	14
4. ASSET MAPPING OF DISCOM.....	18
5. ENERGY CONSERVATION MEASURES SUMMARY.....	122
ENERGY FLOW ANALYSIS.....	125
1. ENERGY FLOW.....	125
2. VALIDATION OF METERED DATA.....	126
3. VALIDATION OF ENERGY FLOW DATA.....	128
LOSS & SUBSIDY COMPUTATION.....	134
1. ENERGY ACCOUNTS ANALYSIS FOR PREVIOUS YEARS- FY 2022-23.....	134
2. ENERGY ACCOUNTS ANALYSIS FOR PRESENT YEAR- FY 2023-24.....	135
3. TECHNICAL LOSSES.....	137
4. HT/LT RATIO.....	219
5. SUBSIDY COMPUTATION AND ANALYSIS.....	220
6. TREND ANALYSIS.....	220
ENERGY AUDIT FINDINGS.....	221
1 COMPLIANCE TO BEE REGULATIONS.....	221
2 NOTES OF THE EA/EM ALONG WITH QUERIES AND REPLIES TO DATA GAPS.....	227
CONCLUSION AND ACTION PLANS.....	229
1 CRITICAL COMMENTS AND ANALYSIS BY ENERGY AUDITOR.....	229
2 ENERGY CONSERVATION MEASURES.....	230
ANNEXURE: COLLECTED DATA.....	237
1. ABOUT THE ACCREDITED ENERGY AUDIT FIRM.....	237
2. CHECKLIST PREPARED BY AUDITING FIRM.....	238

3.	APPROACH, SCOPE & METHODOLOGY OF ENERGY AUDIT	239
4.	INFRASTRUCTURE DETAILS	248
5.	ELECTRICAL DISTRIBUTION SYSTEM	250
6.	POWER PURCHASE DETAILS	256
7.	SINGLE LINE DIAGRAM	259
8.	CATEGORY OF SERVICE DETAILS	261
9.	FIELD VERIFICATION DATA	264
10.	LIST OF DOCUMENTS VERIFIED WITH EACH PARAMETER	271
11.	DETAILED FORMATS TO BE ANNEXED	272
12.	ABBREVIATIONS	290

LIST OF TABLES

TABLE 1: ENERGY AUDIT TEAM	3
TABLE 2: SUMMARY OF DISCOM – FORM-1	9
TABLE 3: ENERGY CONSERVATION MEASURES	9
TABLE 4: GENERAL OBSERVATIONS AND SUGGESTIONS	10
TABLE 5: SOLAR GENERATION SHARE	10
TABLE 6: PERIOD OF ENERGY AUDIT & ACCOUNTING – AS PER BEE GUIDELINES	12
TABLE 7: PROGRESS IN ENERGY ACCOUNTING	12
TABLE 8: NAME AND ADDRESS OF DESIGNATED CONSUMER	13
TABLE 9: ENERGY AUDIT CELL	13
TABLE 10: SUMMARY OF DISCOM – FORM-1	14
TABLE 11: T & D LOSS – SUMMARISED – FEEDER WISE	14
TABLE 12: MAJOR ENERGY PARAMETERS – TCED DISCOM	16
TABLE 13: METERED READING OF INPUT ENERGY	17
TABLE 14: FEEDER LIST	18
TABLE 15: HT LINE DISTANCE – BINI FEEDER	19
TABLE 16: HT LINE DISTANCE – CHEMBUKAVU FEEDER	23
TABLE 17: HT LINE DISTANCE – EAST FORT FEEDER	30
TABLE 18: HT LINE DISTANCE – JUBILEE MISSION FEEDER	35
TABLE 19: HT LINE DISTANCE – KOORKANCHERY FEEDER	37
TABLE 20: HT LINE DISTANCE – RAMANILAYAM FEEDER	41
TABLE 21: HT LINE DISTANCE – SHORNUR ROAD FEEDER	47
TABLE 22: HT LINE DISTANCE – VELIYANOOR FEEDER	56
TABLE 23: HT LINE DISTANCE – VIVEKODAYAM FEEDER	62
TABLE 24: HT LINE DISTANCE – DISTRICT HOSPITAL FEEDER	68
TABLE 25: HT LINE DISTANCE – ARANATTUKARA FEEDER	78
TABLE 26: HT LINE DISTANCE – KOTTAPURAM FEEDER	85
TABLE 27: HT LINE DISTANCE – VANCHIKULAM FEEDER	92
TABLE 28: HT LINE DISTANCE – KERALAVARMA FEEDER	99
TABLE 29: HT LINE DISTANCE – MISSION QUARTERS FEEDER	104
TABLE 30: HT LINE DISTANCE – M O ROAD FEEDER	111
TABLE 31: HT LINE DISTANCE – PARAVATTANI FEEDER	115
TABLE 32: HT LINE DISTANCE – POONKUNAM FEEDER	118
TABLE 33: ENERGY CONSERVATION MEASURES - SUMMARY	123

TABLE 34: ENERGY CONSERVATION MEASURES ADOPTED/TAKEN	124
TABLE 35: TCED INCOMER METER – DEVIATION WITH PQ ANALYSER.....	126
TABLE 36: DEVIATION OF FEEDER METERS	127
TABLE 37: OBSERVATIONS & RECOMMENDATION – ENERGY CONSUMPTION PROFILE	132
TABLE 38: FEEDER WISE SALES DATA FY 2023-24.....	133
TABLE 39: SUMMARY OF DISCOM – FY 2022-23	134
TABLE 40: AT & C LOSS – FY 2022-23	134
TABLE 41: DIVISION WISE LOSSES	135
TABLE 42: AT & C LOSS – FY 2023-24	136
TABLE 43: TCED DISTRIBUTION –LINE DETAILS	137
TABLE 44: LOSS ANALYSIS – BINI FEEDER.....	139
TABLE 45: LOSS ANALYSIS – RAMANILAYAM FEEDER.....	143
TABLE 46: LOSS ANALYSIS – SHORNUR ROAD FEEDER.....	147
TABLE 47: LOSS ANALYSIS - CHEMBUKAVU.....	155
TABLE 48: LOSS ANALYSIS – JMC.....	159
TABLE 49: LOSS ANALYSIS – VIVEKODHAYAM	159
TABLE 50: LOSS ANALYSIS – VELIYANOOR	163
TABLE 51: LOSS ANALYSIS – EAST FORT.....	166
TABLE 52: LOSS ANALYSIS – KERALAVARMA.....	171
TABLE 53: LOSS ANALYSIS – MISSION QUARTERS.....	177
TABLE 54: LOSS ANALYSIS – PARAVATTANY	181
TABLE 55: LOSS ANALYSIS – KOORKKENCHERY.....	185
TABLE 56: LOSS ANALYSIS – POONKUNAM.....	189
TABLE 57: LOSS ANALYSIS – M. O ROAD.....	195
TABLE 58: LOSS ANALYSIS – DH.....	202
TABLE 59: LOSS ANALYSIS – VANCHIKULAM	208
TABLE 60: T & D LOSS SUMMARY – MISSION QUARTERS FEEDER.....	214
TABLE 61: T & D LOSS – VELEYANOOR FEEDER	214
TABLE 62: T & D LOSS KOORKKENCHERY FEEDER	214
TABLE 63: T & D LOSS SUMMARY – PARAVATTANY FEEDER.....	215
TABLE 64: T & D LOSS SUMMARY – JMC FEEDER	215
TABLE 65: T & D LOSS SUMMARY – VIVEKODHAYAM FEEDER.....	215
TABLE 66: T & D LOSS SUMMARY – BINI FEEDER.....	216
TABLE 67: T & D LOSS SUMMARY – POONKUNAM FEEDER.....	216
TABLE 68: T & D LOSS – KERALAVARMA FEEDER.....	216
TABLE 69: T & D LOSS SUMMARY – RAMANILAYAM FEEDER.....	217
TABLE 70: T & D LOSS – M.O ROAD FEEDER.....	217
TABLE 71: T & D LOSS – CHEMBUKAVU FEEDER.....	218
TABLE 72: T & D LOSS – SHORNUR ROAD FEEDER.....	218
TABLE 73: T & D LOSS – DISTRICT HOSPITAL FEEDER.....	218
TABLE 74: T & D LOSS – EASTFORT FEEDER.....	219
TABLE 75: T & D LOSS – VANCHIKULAM FEEDER.....	219
TABLE 76: HISTORICAL ENERGY ACCOUNTS/LOSS OF THE DISCOM.....	220
TABLE 77: QUERIES AND REPLIES TO DATA GAPS	227
TABLE 78: ANALYSIS ON T&D LOSSES.....	229
TABLE 79: SOLAR GENERATION SHARE	229

TABLE 80 : OVERHEAD LINES DETAILS230

TABLE 81 : ECM 01231

TABLE 82: ECM 02232

TABLE 83: PF & REACTIVE POWER OF MAJOR FEEDERS233

TABLE 84: ECM 03234

TABLE 85: LOW LOADING TRANSFORMER LIST235

TABLE 86: ECM-04.....236

TABLE 87: CONTACT DETAILS OF AEA & CEA237

TABLE 88: ACTIVITY CHART – ENERGY AUDIT.....239

TABLE 89: EQUIPMENT LIST247

TABLE 90: INFRASTRUCTURE DETAILS.....248

TABLE 91: SUBSTATION TRANSFORMER DETAILS252

TABLE 92: DISTRIBUTION FEEDER NAME.....252

TABLE 93: SWITCHING STATION – 11 KV UG CABLE DETAILS253

TABLE 94: TCED DISTRIBUTION –LINE DETAILS254

TABLE 95: FEEDER WISE TRANSFORMER DATA - SUMMARY255

TABLE 96: AVERAGE PURCHASE COST – DISCOM.....257

TABLE 97: ACS- ARR GAP.....258

TABLE 98: DETAILS OF CONSUMERS AND CONSUMPTION261

TABLE 99: DIVISION WISE STATUS OF DT LEVEL METERING262

TABLE 100: DT WISE LOSSES263

TABLE 101: INCOMER MEASUREMENT DATA.....264

TABLE 102: HARMONICS CLASSIFICATION267

TABLE 103: CURRENT HARMONICS LIMIT (IEEE 519-2014).....267

TABLE 104: VOLTAGE HARMONICS LIMIT (IEEE 519-2014)267

TABLE 105: STANDARD LIMITS AS PER THE IEEE 519-2014 – AT TCED INCOMER268

TABLE 106: HARMONICS VALUES – TCED INCOMER268

TABLE 107: OBSERVATIONS & RECOMMENDATION – ELECTRICAL NETWORK CONFIGURATION269

TABLE 108: LIST OF DOCUMENTS VERIFIED.....271

TABLE 109: ENERGY BILL SUMMARY – FY 2023-24- 110 KV INCOMER.....276

TABLE 110: ENERGY BILL SUMMARY – FY 2023-24- 66 KV INCOMER277

LIST OF FIGURES

FIGURE 1: ENERGY FLOW DIAGRAM - TCED.....	15
FIGURE 2: BINI FEEDER.....	22
FIGURE 3: CHEMBUKAVU FEEDER.....	29
FIGURE 4: EAST FORT FEEDER.....	34
FIGURE 5: JUBILEE MISSION FEEDER.....	36
FIGURE 6: KOORKANCHERY FEEDER.....	40
FIGURE 7: RAMANILAYAM FEEDER.....	46
FIGURE 8: SHORNUR ROAD FEEDER.....	55
FIGURE 9: VELIYANOOR FEEDER.....	61
FIGURE 10: VIVEKODAYAM FEEDER.....	67
FIGURE 11: DISTRICT HOSPITAL FEEDER.....	77
FIGURE 12: ARNATTUKARA FEEDER.....	84
FIGURE 13: KOTTAPURAM FEEDER.....	91
FIGURE 14: VANCHIKULAM FEEDER.....	98
FIGURE 15: KERALAVARMA FEEDER.....	103
FIGURE 16: MISSION QUARTERS FEEDER.....	110
FIGURE 17: M O ROAD FEEDER.....	114
FIGURE 18: PARAVATTANI FEEDER.....	117
FIGURE 19: POONKUNAM FEEDER.....	121
FIGURE 20: ENERGY FLOW DIAGRAM - TCED.....	125
FIGURE 21: DEMAND VARIATION – FY 2023-24.....	129
FIGURE 22: ENERGY CONSUMPTION ANALYSIS.....	130
FIGURE 23: POWER FACTOR – FY 2023-24.....	131
FIGURE 24: HISTORICAL T & D LOSS WITH AUDITED DATA.....	220
FIGURE 25: SCHEMATIC REPRESENTATION OF TECHNICAL LOSSES.....	243
FIGURE 26: AVERAGE BILLING RATE – CATEGORY WISE.....	256
FIGURE 27: 110 KV & 66 KV SUBSTATION.....	259
FIGURE 28: 33 KV SUBSTATION.....	260
FIGURE 29: POWER VARIATIONS – CONTINUOUS LOGGED DATA.....	265
FIGURE 30: DEMAND VARIATIONS – CONTINUOUS LOGGED DATA.....	266
FIGURE 31: POWER FACTOR – VARIATIONS.....	266
FIGURE 32: VOLTAGE HARMONIC SPECTRUM.....	268
FIGURE 33: CURRENT HARMONIC SPECTRUM.....	268
FIGURE 34 :BALANCE SHEET – FY 2023-24.....	272
FIGURE 35:PROFIT & LOSS STATEMENT.....	273

EXECUTIVE SUMMARY

1. PERFORMANCE SUMMARY

The performance summary of TCED as DISCOM as per the FY 2023-24 is given in the following table.

TABLE 2: SUMMARY OF DISCOM – FORM-1

Performance Summary of Electricity Distribution Companies			
1	Period of Information Year of (FY) information including Date and Month (Start & End)	1st Apr, 2023 - 31st March, 2024	
2	Technical Details		
(a)	Energy Input Details		
(i)	Input Energy Purchase (From Generation Source)	Million kWh	182.078
(ii)	Net input energy (at DISCOM Periphery including sale outside periphery)	Million kWh	182.078
(iii)	Total Energy billed (is the Net energy billed, adjusted for energy traded)	Million kWh	169.87
(b)	Transmission and Distribution (T & D) loss (Billing efficiency)	Million kWh	12.209
		%	6.71
(i)	Collection Efficiency	%	99.22%
(c)	Aggregate Technical & Commercial Loss	%	7.43%

2. ENERGY CONSERVATION MEASURES SUMMARY

The TCED can consider several possible measures for energy conservation to reduce their distribution loss to their best value as summarised in the executive summary.

TABLE 3: ENERGY CONSERVATION MEASURES

EC M No	Energy Efficiency Measures	Annual Electricity Savings	Annual Financial Savings	Investment	Fixed interest rate	Cash inflow	Net present value	Internal rate of return
		MU	(Rs)	(Rs)	%	Years	Rs	%
1	Replacing HT & LT overhead lines with UG cables***	0.987	64,19,547	1,75,45,800	8	5	37,16,553	17.19%
2	Replacing Two nos of Old Transformers with Energy Efficient transformers	0.01205	78,336	14,00,000	8	20	-6,30,888	1.10%
3	Power Factor Improvement in Feeders – installation of 420 kVAr total	-	2,45,15,506	37,50,000	8	1	1,89,49,542	553.75%
4	Steps to ensure the reduction of losses in transformer - sample calculation	0.7434	4,94,361	22,50,000	8	6	35,371	8.52%

***At 11 kV = 8.273 km & at 415 V = 20.97 km

3. GENERAL OBSERVATIONS AND SUGGESTIONS

TABLE 4: GENERAL OBSERVATIONS AND SUGGESTIONS

Observation	Suggestions	Benefits
<p>Collection efficiency of the DISCOM has been improved to 99.22% from 97.36%.</p> <p>As per the TCED availed data, the major dues are from the Government departments, urban local bodies, street light and corporation owned buildings.</p>	<p>Collection drives should be placed in the DISCOM area.</p> <p>Awareness shall be provided for the proper billing in due time.</p> <p>Energy cell can give awareness in the DSM and various energy efficiency measures to help them in reducing the consumption.</p>	<p>Collection efficiency of the DISCOM is 99.22% which resulted in improvement of AT & C loss from 9.54 %(FY-2022-23) to 7.43% (FY-2023-24)</p> <p>As per the TCED availed data, the major dues are from the Government departments, urban local bodies, street light and corporation owned buildings.</p>
<p>As the back-feed units from one feeder to another were not available in the DISCOM, exact loss analysis was unable to calculate from the existing data.</p>	<p>Feeder boundary energy meter is suitable option to have the back-feed data and records shall be maintained properly.</p>	<p>As the back-feed units from one feeder to another were not available in the DISCOM, exact loss analysis was unable to calculate from the existing data.</p>

4. COMPLIANCE TO RENEWABLE PURCHASE OBLIGATIONS

TCED purchasing the 97.89% of the power consumed through KSEBL. As the KSEBL is on the verge of meeting the RPO obligation, the same can consider for the TCED.

Table 5: Solar generation share

Total Energy Consumption FY 2023-24 (MU)	182.078	
Details	Solar generation	Non-solar generation
Present status - MU	3.85	0
Present status - %	2.11%	0

BACKGROUND

1. ABOUT BEE

The Government of India has set up Bureau of Energy Efficiency (BEE) on 1st March 2002 under the provision of the Energy Conservation Act, 2001. The mission of Bureau of Energy Efficiency is to assist in developing policies and strategies with a thrust on self-regulation and market principles with the primary objective of reducing energy intensity of the Indian economy within the overall framework of the Energy Conservation Act, 2001. This will be achieved with active participation of all stakeholders, resulting into accelerated and sustained adoption of energy efficiency in all sectors.

2. EXTANT OF REGULATIONS - DISCOM

Under the notification S.O. 3445 (E) dated 28 Sept 2020, all entities having distribution license are notified as Designated Consumers. Notification is read as "All entities having issued distribution license by State/Joint Electricity Regulatory Commission under the Electricity Act, 2003 (36 of 2003)" are notified as Designated Consumers (DCs). After this notification, all the DISCOMs will be governed under the various provisions of Energy Conservation Act, such as Appointment of Energy Manager, Energy Accounting & Auditing, identification of Energy Losses Category wise, Implementation of energy conservation & efficiency measures etc.

The amendment is expected to help DISCOMs to monitor their performance parameters and bring in transparency in the Distribution sector through professional inputs. It will also assist in developing projects for reducing the electricity losses by DISCOMs and implementing effective solutions. The amendment is expected to improve the financial state of the DISCOMs.

In exercise of the powers conferred by clause (g) of sub-section (2) of section 58, read with clause (q) of sub-section (2) of section 13 of the Energy Conservation Act, 2001 (52 of 2001), the Bureau of Energy Efficiency, thus made the following regulations:

- 3 **Named as** Bureau of Energy Efficiency (Manner and Intervals for Conduct of Energy Audit in electricity distribution companies) Regulations, 2021.
- 4 These regulations shall apply to all electricity distribution companies specified as designated consumer.
- 5 They shall come into force on the date of their publication in the Official Gazette. (No: CG-DL-E-08102021-230245 Dated 06 October 2021).

3. PURPOSE OF AUDIT AND ACCOUNTING REPORT

Energy accounting and a consequent annual energy audit would help to identify areas of high loss and pilferage, and thereafter focus efforts to take corrective action. Energy Accounting means accounting of all energy inflows at various voltage levels in the distribution periphery of the network, including renewable energy generation and open access consumers, and energy consumption by the end consumers.

Owing to the impact of energy auditing on the entire distribution and retail supply business and absence of an existing framework with dedicated focus on the same, it was imperative to develop a set of comprehensive guidelines that all Distribution utilities across India can follow and adhere to.

4. PERIOD OF ENERGY AUDIT AND ACCOUNTING

The table below shows the frequency of energy audit and energy accounting as per the BEE guidelines.

Table 6: Period of Energy Audit & Accounting – as per BEE guidelines

Particulars	Frequency	Submission date	Whom to submit	Who should submit
Energy audit	Every year	Within a period of 4 months from the expiry of the relevant financial year	BEE & SDA	Accredited energy auditor
Energy accounting	Quarterly	45 days from the quarter	BEE & SDA	Certified energy manager

TCED has initiated the energy audit in the month of July 2023 in order to submit the Energy audit report. Thus, the TCED entrusted the work to CEEP as per the work order no: BEE/DISCOM-8574/23 dated 30th May 2024 and the latter started the field study by last week of July- field study for 18 days - and draft report submitted on 12th August 2024.

5. PROGRESS IN COMPLIANCE TO PREREQUISITES TO ENERGY ACCOUNTING

Table 7: Progress in energy accounting

Quarter	Submission date	Ref no
1 st Quarter – 1 st April 2023 to 30 th June 2023	15-08-2023	Mail
2 nd quarter – 1 st July 2023 to 30 th Sept 2023	15-11-2023	Mail
3 rd Quarter - 1st Oct 2023 to 31st Dec 2023	19-02-2024	Mail
4 th Quarter – 1 st Jan 2024 to 31 st Mar 2024	15-05-2024	Mail

DISCOM INTRODUCTION AND OVERVIEW

1. NAME AND ADDRESS OF DESIGNATED CONSUMER

Table 8: Name and address of designated consumer

General Details	Description
Registered Office address with telephone, fax nos. & e-mail	M/s Thrissur Corporation Electricity Department (TCED), Thrissur Corporation, MO Road, Thrissur District-Kerala - 680001. Ph: 0487 2422470
Company Chief executive name & details	Assistant Secretary M/s Thrissur Corporation Electricity Department (TCED), Thrissur Corporation, MO Road, Thrissur District-Kerala -680001. Ph: 0487 2422470 Email: electricitydepartment@yahoo.co.in
Authorized signatory of DC (Nodal Officer)	Mr. Jose T S Electrical Engineer M/s Thrissur Corporation Electricity Department (TCED), Thrissur Corporation, MO Road, Thrissur District-Kerala - 680001. Ph: 0487 2423559
Energy Manager's Name, Designation, Registration No., Address, Mobile, Telephone, Fax nos. & e-mail	Mr. Nikhil B Assistant Engineer/CEA 24811 M/s Thrissur Corporation Electricity Department (TCED), Thrissur Corporation, MO Road, Thrissur District-Kerala - 680001. Mob: 9037192013

2. ENERGY AUDIT CELL

Table 9: Energy audit cell

Sr	Member of EAC	Name	Designation	Mobile number	Email
1	Nodal officer	Mr. Jose T Simon	Electrical Engineer	9446019795	electricitydepartment@yahoo
2	Energy Auditor	Mr. Nikhil B	Assistant engineer/Energy Auditor CEA 24811	9037192013	
3	IT manager	Ms. Deepa S	System Administrator	9048267195	
4	Financial manager	Mr. Baburaj N	Senior Superintend	8921364952	

3. SUMMARY PROFILE OF DISCOM - FORM-1

The performance summary of TCED as DISCOM as per the FY 2023-24 is given in the following table.

Table 10: Summary of DISCOM – Form-1

Performance Summary of Electricity Distribution Companies			
1	Period of Information Year of (FY) information including Date and Month (Start & End)	1 st Apr, 2023 - 31 st March, 2024	
2	Technical Details		
(a)	Energy Input Details		
(i)	Input Energy Purchase (From Generation Source)	Million kWh	182.078
(ii)	Net input energy (at DISCOM Periphery including sale outside periphery)	Million kWh	182.078
(iii)	Total Energy billed (is the Net energy billed, adjusted for energy traded)	Million kWh	169.87
(b)	Transmission and Distribution (T&D) loss (Billing efficiency)	Million kWh	12.209
		%	6.71
	Collection Efficiency	%	99.22%
(c)	Aggregate Technical & Commercial Loss	%	7.43%

The feeder wise T&D loss of the TCED distribution system is calculated based on the annual unit consumption for 16 feeders and summarized in the following table:

Table 11: T & D loss – Summarised – feeder wise

Sl. No	Feeder	Net energy sales - annual	LT OH line loss	LT Cable loss	Transformer Loss	HT OH & cable line loss	Estimated Consumption at feeder level	T&D Loss - calculated	
		MU	MU	MU	MU	MU	MU	MU	%
1	Mission Quarters	9.405	0.985	0.017	0.187	0.003	10.60	1.19	11.25
2	Veliyanoor	7.464	0.685	0.015	0.108	0.002	8.27	0.81	9.78
3	Koorkanchery	9.731	1.721	0.035	0.141	0.005	11.63	1.90	16.35
4	Paravattani	8.306	1.200	0.045	0.152	0.006	9.71	1.40	14.44
5	JMC	8.935	-	-	-	0.004	8.94	0.00	0.05
6	Vivekodayam	7.305	0.773	0.024	0.109	0.002	8.21	0.91	11.04
7	Bini	5.718	0.157	0.003	0.095	0.001	5.97	0.26	4.28
8	Poonkunnam	7.753	0.000	0.001	0.013	0.000	7.77	0.01	0.18
9	Keralavarma	10.065	1.009	0.031	0.216	0.008	11.33	1.26	11.15
10	Ramanilayam	7.211	0.202	0.007	0.094	0.002	7.52	0.31	4.06
11	M O Road	11.453	0.002	0.012	0.157	0.002	11.63	0.17	1.50
12	Chembukavu	10.218	1.009	0.025	0.137	0.005	11.39	1.18	10.33
13	Shornur Road	11.216	0.421	0.035	0.214	0.002	11.89	0.67	5.65
14	District Hospital	11.327	0.002	0.042	0.174	0.004	11.55	0.22	1.92
15	East Fort	12.105	1.541	0.036	0.191	0.006	13.88	1.78	12.79
16	Vanjikulam	7.877	0.001	0.016	0.147	0.003	8.04	0.17	2.07
	Total	52.743	2.974	0.154	0.864	0.021	56.76	4.01	7.07

Note:

- **Sampled T&D loss calculation & analysis conducted for 16 out of 18 feeders. The feeder wise LT line length, consumer numbers, types and transformer details were not present for the remaining ones during the audit period.**
- The DISCOM is mapping the consumers and its assets in the due process under the RDSS.

Energy flow diagram is given below in figure:

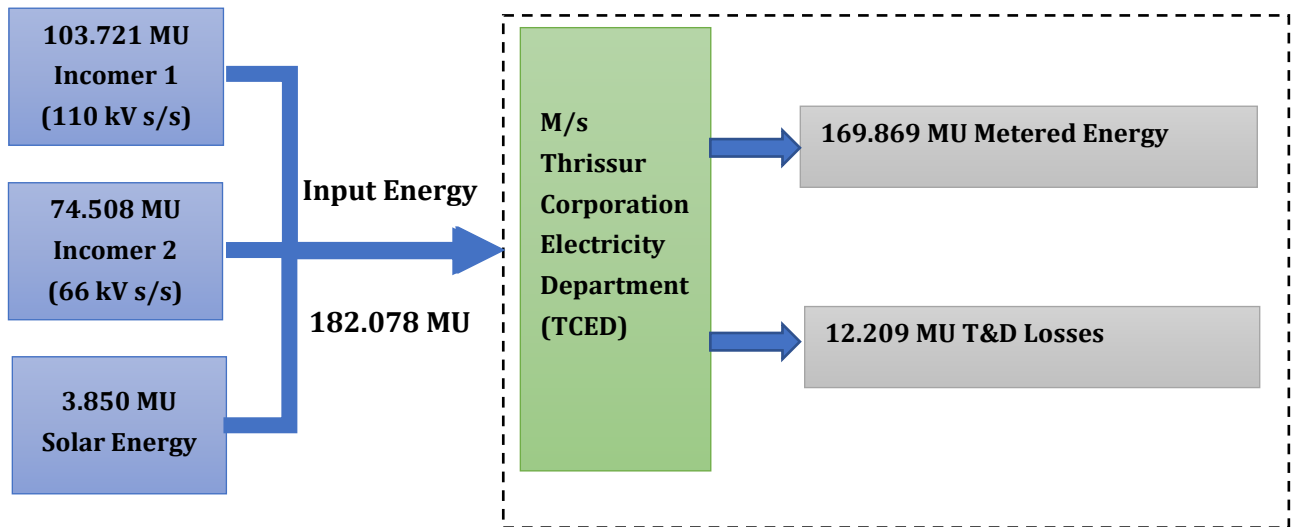

Figure 1: Energy flow diagram - TCED

- *Input energy = the energy received at the TCED for distribution.*
- *Metered energy = energy metered at the consumer end*
- *T&D losses = Net losses*

FORM INPUT ENERGY

The table below shows the **major energy parameters for the FY 2023-24**

Table 12: Major energy parameters – TCED DISCOM

Form-Input energy (Details of Input energy & Infrastructure)			
A. Summary of energy input & Infrastructure			
S. No	Parameters	Period from April 2023 to March 2024	Remarks (Source of data)
A.1	Input Energy purchased (MU)	182.078	Electricity bill & solar export
A.2	Transmission loss (%)	0%	
A.3	Transmission loss (MU)	0	
A.4	Energy sold outside the periphery (MU)	0.00	
A.5	Open access sale (MU)	0	
A.6	EHT sale	0	
A.7	Net input energy (received at DISCOM periphery or at distribution point)-(MU)	182.078	Total net input
A.8	Is 100% metering available at 66/33 kV (Select yes or no from list)	Yes	
A.9	Is 100% metering available at 11 kV (Select yes or no from list)	Yes	
A.10	% of metering available at DT	59.50%	286 out of 480 transformers
	Total number of DT (Nos)	480	
A.11	Total number of consumers (Nos)	42995	
	Number of HT consumers (Nos)	139	
	Number of LT consumers (Nos)	42856	
A.12	% of metering available at consumer end	100%	
A.13	No of feeders at 66kV voltage level	0	
A.14	No of feeders at 33kV voltage level	0	
A.15	No of feeders at 11kV voltage level	18	
A.16	No of LT feeders' level	0	Not available
A.17	Line length (ckt. km) at 66kV voltage level	0	
A.18	Line length (ckt. km) at 33kV voltage level	4.2	Measured through HT line mapping
A.19	Line length (ckt. km) at 11kV voltage level	117.278	Measured through HT line mapping
A.20	Line length (km) at LT level	287.953	Measured through LT line mapping
A.21	Length of Aerial Bunched Cables	1.85	Measured through HT line mapping
A.22	Length of Underground Cables	81.07	Site measurement
A.23	HT/LT ratio	1/2.335	

Table 13: Metered reading of input energy

B. Meter reading of Input energy at injection points																
S. No	Zone	Circle	Voltage Level (KV)	Feeder Name	Feeder Metering Status (Metered/unmetered/AMI/AMR)	Status of Meter (Functional/Non-functional)	Metering Date	Feeder Type (Agri/Industrial/Mixed)	Status of Communication			Period from April 2023 to March 2024				Remarks (Source of data)
							Date of last actual meter reading/communication		% data received through automatically if feeder AMR	Number of hours when meter was unable to communicate in period	Total Number of hours in the period	Meter S. No	CT/PT ratio	Import (MU)	Export (MU)	
B. 1	TC ED	TC ED	110	VIPL	Metered	Functioning	01-04-2024	Mixed	0	0	NA	X2005320	200/1	103.721	-	110 kV s/s
B. 2	TC ED	TC ED	66	OLVI	Metered	Functioning	01-04-2024	Mixed	0	0	NA	17052040	200/1	74.507	-	66 kV s/s
B. 3	TC ED	TC ED	0.4	Multiple feeders	Metered	Functioning	01-04-2024	Mixed	0	0	NA	-	-	3.310		Consumer bills
B. 4	TC ED	TC ED	11	Multiple feeders	Metered	Functioning	01-04-2024	Mixed	0	0	NA	-	-	0.540		Consumer bills
Total (MU)													182.078	0.0		
Net input energy at DISCOM periphery (MU)													182.078			

4. ASSET MAPPING OF DISCOM

MAPPING - DT & 11 KV OH LINE

Mapping of the transformer, pole and 11 kV consumers were done to evaluate the distance which helps to calculate the HT line loss in TCED.

GPS mapping was made using the Google map/ GPS meter collecting the latitude and longitude, and later projected into the relevant free software by naming the specific pole, DT and 11 kV consumer with serial numbers. The GPS mapping of HT lines done for 18 feeders and the details are analyzed in this section.

Feeder wise HT line mapping is given below in charts in representation purpose and the distance of the DT from each substation is given in the table below.

FEEDER WISE MAPPING

There are 18 mapped feeders, and the new distribution transformers (DTs) on the line have been updated and mapped as well. The feeders are listed below.

Table 14: Feeder List

Feeder No	Feeder	No: of Transformer
1	Mission Quarters	31
2	Veliyanoor	18
3	Koorkenchery	23
4	Paravattani	25
5	Arnattukkara	31
6	Jubilee Mission	Dedicated feeder HT
7	Vivekodhayam	21
8	Bini	16
9	Poonkunam	33
10	Keralavarma	38
11	Ramanilayam	19
12	M O Road	33
13	Kottappuram	39
14	Chembukavu	25
15	Shornur Road	44
16	DH	34
17	East Fort	27
18	Vanjikulam	23
	Total	480

Feeder-wise high-tension (HT) line mapping is provided in the charts for representation purposes. The distance of the DT from the switching station is detailed in the table below.

1 BINI FEEDER

The following table shows the HT line distance of the 11 kV lines.

Table 15: HT line distance – Bini feeder

From Map no	Map no	Pole/transformer/ AB	Latitude	Longitude	Cable	Cable type	Cable size (sq mm)	Mapping distance (m)	Loose distance (m)	Total distance (m)
SS	2P	2P	10.535256	76.214482	UG	XLPE	300		10	10
2P	P1	Post	10.535166	76.214903	UG	XLPE	300	56.45	8	64.45
P1	P19	Post	10.531830	76.215107	OH	Racoon				0
P19	P2	Post	10.534960	76.215040	OH	Racoon		374.22		374.22
P2	RMU-30801	RMU-30801	10.531838	76.215015	UG	XLPE	300		10	10
RMU-30801	2	TT Devassy	10.531879	76.214960	UG	XLPE	300	18.02	2	20.02
P2	P3	Post	10.531335	76.215078	OH	Racoon				0
P3	P4	Post	10.531049	76.215114	OH	Racoon				0
P4	P5	Post	10.529577	76.214890	OH	Racoon		251.84		251.84
P5	P6	Post	10.529488	76.215092	OH	Racoon				0
P6	P20	Post	10.52926	76.21616	OH	Racoon				0
P20	P7,29	Vadakke chira	10.529356	76.216230	OH	Racoon		159.34		159.34
P7	P8	Post	10.529546	76.216378	OH	Racoon		26.45		26.45
P8	4	Lake View	10.529449	76.216594	UG	XLPE	300	25.78	5	30.78
P7	ABI-50802	ABI-50802	10.529068	76.216227	OH	Racoon				0
P7	P9	Post	10.528870	76.216152	OH	Racoon				0
P9	P10	Post	10.527645	76.215877	OH	Racoon		193.79		193.79
P10	5	Seethal Apartment	10.527505	76.216275	UG	XLPE	300	46.05	5	51.05
P10	P10-1	Post	10.527543	76.216062	OH	Racoon		22.6		22.6
P10-1	6	Kalyan Jewellers	10.527462	76.216232	UG	XLPE	240	21.37	50	71.37
P5	P11	Post	10.529458	76.214614	OH	Racoon		33.69		33.69
P11	P12	Post	10.529484	76.214194	OH	Racoon		46.27		46.27
P12	1	Mangala Tower	10.529553	76.214261	UG	XLPE	185	10.92	10	20.92
P12	P21	Post	10.52949	76.21346	OH	Racoon				0
P21	P13	Post	10.529547	76.213178	OH	Racoon		111.57		111.57

From Map no	Map no	Pole/transformer/ AB	Latitude	Longitude	Cable	Cable type	Cable size (sq mm)	Mapping distance (m)	Loose distance (m)	Total distance (m)
P13	3	Paliyam Road	10.529485	76.213167	OH	Racoon		7.4		7.4
P13	P13-1	Post	10.529615	76.213168	OH	Racoon		7.6		7.6
P13-1	26	Ashiana Apartments	10.529910	76.213040	UG	XLPE	240	35.64	20	55.64
P11	P14	Post	10.529163	76.214639	OH	Racoon				0
P14	ABL-50803	ABL-50803	10.528369	76.214367	OH	Racoon		125.93		125.93
ABL-50803	10	Pallithammam	10.528262	76.213578	UG	XLPE	240	87.23	5	92.23
10	LBS,16	SBI- Pallithammam	10.528090	76.213650	UG	XLPE	185	20.13	2	22.13
LBS	12	Elite Supermarket (Pallithammam)	10.528137	76.213650	UG	XLPE	185	5.2	1	6.2
LBS	11	Pallithammam (Indoor)	10.528185	76.213651	UG	XLPE	185	5.31	10	15.31
10	LBS,14	LBS, Kairali Sree Theatre 2	10.528141	76.213761	UG	XLPE	240	12.99	3	15.99
LBS	13	Kairali Sree Theatre 1	10.528073	76.213925	UG	XLPE	240	19.46	35	54.46
ABL-50803	P15	Post	10.528289	76.214548	OH	Racoon		21.7		21.7
P15	7	AGS Office	10.528266	76.214609	OH	Racoon		7.15		7.15
7	8	Cochin Dewasm Board	10.528197	76.214594	OH	Racoon		7.81		7.81
ABL-50803	P17	Post	10.528113	76.214334	OH	Racoon		28.55		28.55
P17	P16	Post	10.527645	76.214347	OH	Racoon				0
P16	P16-1	Post	10.527677	76.214684	OH	Racoon				0
P16-1	P16-2	Post	10.527742	76.215051	OH	Racoon		129.44		129.44
P16-2	9	Kailasam	10.527841	76.215127	UG	XLPE	300	14.11	28	42.11
P17	P16	Post	10.527645	76.214347	OH	Racoon		51.79		51.79
P16	P16-3	Post	10.527616	76.214282	OH	Racoon		7.8		7.8
P16-3	25	Bini Tourist Home	10.527769	76.214029	UG	XLPE	185	32.45	25	57.45
P17	G1	Ground	10.527570	76.214301	UG	XLPE	300		7	7
G1	G2	Ground	10.526835	76.212525	UG	XLPE	300			0
G2	24	Vegetable	10.527160	76.212504	UG	XLPE	300	303.92	5	308.92
24	G2				UG	XLPE				
G2	17	Dhanalakshmi Bank	10.52686	76.212190	UG	XLPE	300	74		74
24	P18	Post	10.527319	76.212319	OH	Racoon		26.71		26.71
P18	15	Chemmannur	10.52732	76.212100	UG	XLPE	240	23.97	40	63.97
24	G2	Ground	10.526835	76.212525	UG	XLPE	300			0

From Map no	Map no	Pole/transformer/ AB	Latitude	Longitude	Cable	Cable type	Cable size (sq mm)	Mapping distance (m)	Loose distance (m)	Total distance (m)
G2	G3	Ground	10.526539	76.212193	UG	XLPE	300			0
G3	G4	Ground	10.526090	76.212030	UG	XLPE	300			0
G4	G5	Ground	10.524329	76.212023	UG	XLPE	300			0
G5	G6	Ground	10.524184	76.211864	UG	XLPE	300			0
G6	G7	Ground	10.524039	76.21133	UG	XLPE	300	438.02		438.02
G7	21	Naduvilal(Pooma)	10.523870	76.211293	UG	XLPE	300	15.66	6	21.66
21	20	Pooma Complex	10.523813	76.211424	UG	XLPE	150	15.66	15	30.66
P25-1	P25	Post	10.523930	76.21127	OH	Racoon		7.51		7.51
P25	P23	Post	10.523980	76.21168	OH	Racoon				0
P23	23, P23-1	Naduvial Shopping complex, Post	10.524120	76.21164	OH	Racoon		61.03		61.03
P23-1	19	Sidish Complex	10.52425	76.21153	OH	ABC		18.57		18.57
P23-1	G6	Ground	10.524184	76.211864	UG	XLPE	300			
G6	G5	Ground	10.524329	76.212023	UG	XLPE	300			
G5	G8	Ground	10.52468	76.212010	UG	XLPE	300			
G8	AB-Ayodhya	AB	10.52466	76.211960	UG	XLPE	300	92.68		92.68
AB-Ayodhya	18	Ayodhya centre	10.52467	76.211780	UG	XLPE	150	20.72	12	32.72
P25	P24	Post	10.52383	76.21069	OH	Racoon		65.54		65.54
P24	AB-Chungath	AB	10.52398	76.21069	OH	Racoon		17.39		17.39
AB-Chungath	22	P22,Chugath Jewellery	10.52398	76.21069	UG	XLPE	300		10	10
P24	RMU-30802, 28	RMU-30802, National Lodge	10.5237	76.21069	UG	XLPE	300	13.75	35	48.75
P24	P26	Post	10.52377	76.21028	OH	Racoon		45.37		45.37
P26	27	Maheswari Apartment	10.52369	76.210190	UG	XLPE	300	12.47	17	29.47

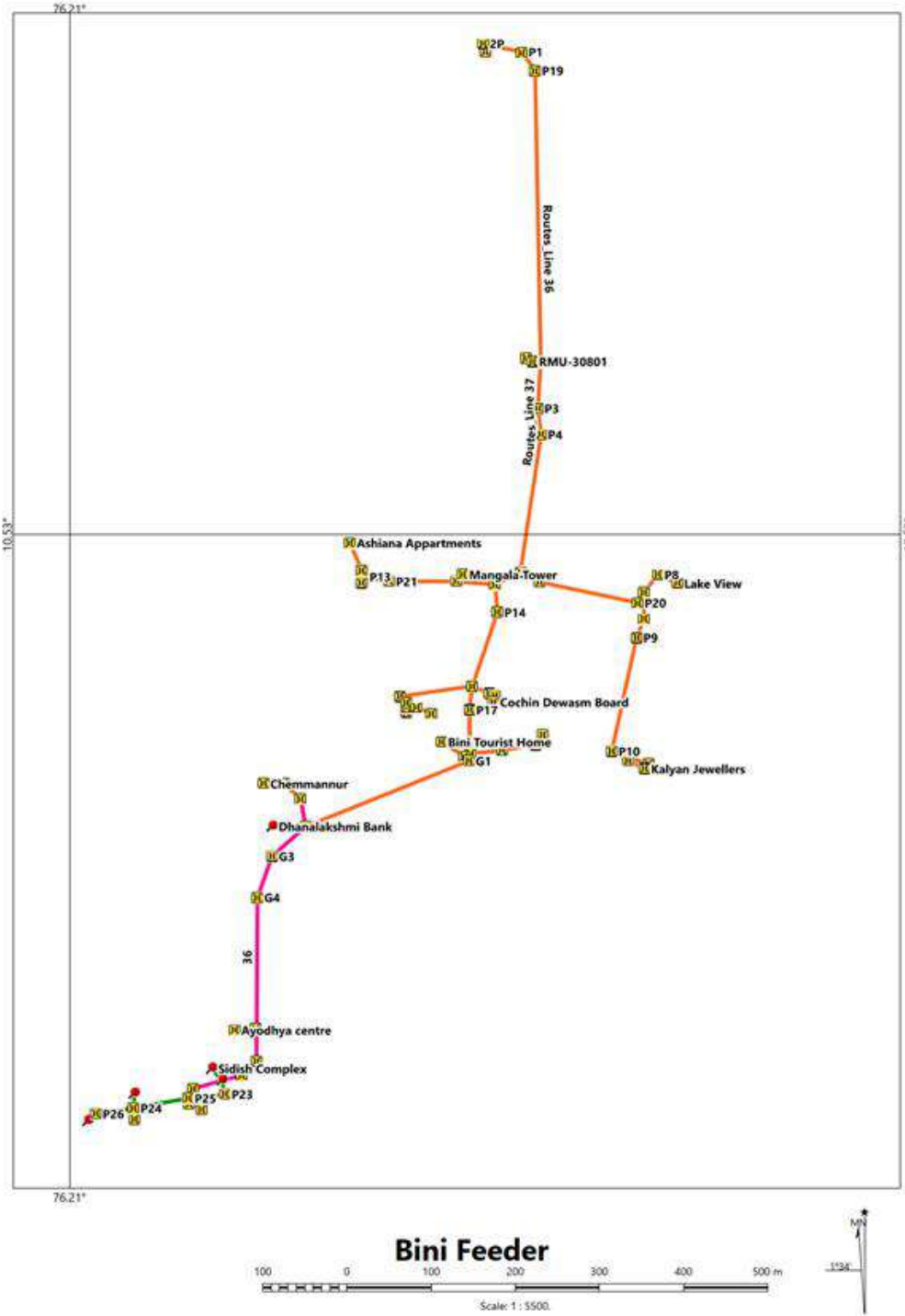

Figure 2: Bini feeder

2 CHEMBUKAVU FEEDER

The following table shows the 11-kV line distance in the Chembukavu feeder.

Table 16: HT line distance – Chembukavu feeder

From Map no	Map no	Pole/transformer/AB	Metering point	Latitude	Longitude	Cable	Cable type	Cable size (sq mm)	Mapping distance (m)	Loose distance (m)	Total distance (m)
	S-S	Substation feeder		10.53517	76.21455						
S-S	P1	Post		10.535240	76.214603	UG	XLPE	300		30	30
P1	G1	Ground		10.535189	76.214889	UG	XLPE	300			0
G1	P2	Post		10.534928	76.215162	UG	XLPE	300	81.76		81.76
P2	AB bb	AB Big Bazar		10.534974	76.215234	OH	Racoon		9.38		9.38
AB bb	1	Big Bazar	HT	10.534844	76.215636	UG	XLPE	300	46.23	7	53.23
P2	G2	Ground		10.53519	76.215239	UG	XLPE	300			0
G2	G3	Ground		10.535286	76.215405	UG	XLPE	300			0
G3	G4	Ground		10.535349	76.216771	UG	XLPE	300			0
G4	G5	Ground		10.535251	76.216929	UG	XLPE	300			0
G5	P3	Post		10.534976	76.216992	UG	XLPE	300	253.99		253.99
P3	RMU31401, 2	Jawahar	LT	10.533837	76.217074	UG	XLPE	300	126		126
RMU31401	RMUn	RMU- Asset Galleria		10.534907	76.216971	UG	XLPE	300	119		119
RMUn	G31	Ground		10.534829	76.216398	UG	XLPE	300			
G31	Asset Galleria	Asset Galleri		10.535123	76.216265	UG	XLPE	300	99	5	104
RMUn	G6	Ground		10.534987	76.217098	UG	XLPE	240			0
G6	G7	Ground		10.534900	76.217125	UG	XLPE	240			0
G7	11	Swathy Residency	LT	10.535036	76.217486	UG	XLPE	240	64	20	84
RMUn	G6	Ground		10.534987	76.217098	UG	XLPE	280			0
G6	G7	Ground		10.534900	76.217125	UG	XLPE	280			0
G7	11	Swathi Residency	LT	10.535036	76.217486	UG	XLPE	280	64.01	20	84.01

From Map no	Map no	Pole/transformer/ AB	Meterin g point	Latitude	Longitude	Cab le	Cable type	Cabl e size (sq mm)	Mappin g distanc e (m)	Loose distanc e (m)	Total distanc e (m)
RMU31401	G8	Ground		10.533219	76.217274	UG	XLPE	300		4	4
G8	P4	Post		10.532999	76.217193	UG	XLPE	300			0
P4	G9	Ground		10.533104	76.217351	UG	XLPE	300			0
G9	G10	Ground		10.532870	76.219178	UG	XLPE	300			0
G10	G11	Ground		10.532621	76.219306	UG	XLPE	300			0
G11	ABL51402	AB		10.532394	76.219318	UG	XLPE	300	382.14		382.14
ABL51402	P5	Post		10.532375	76.219396	OH	Racoon				0
P5	P6	Post		10.531637	76.219399	OH	Racoon		90.42		90.42
P6	AB KSFE	AB		10.531489	76.219285	OH	Racoon		20.58		20.58
AB KSFE	15	KSFE	HT	10.531484	76.219105	UG	XLPE	240	19.71	7	26.71
P6	P7	Post		10.531032	76.219422	OH	Racoon				0
P7	P8	Post		10.530808	76.219429	OH	Racoon		91.76		91.76
P8	ABI51105	AB		10.530816	76.218397	OH	Racoon		112.96		112.96
P8	ABI51403	AB		10.529985	76.219392	OH	Racoon		91.12		91.12
P8	P9	Post		10.530807	76.219894	OH	Racoon		50.9		50.9
P9	AB Central Hotel	AB		10.530901	76.219834	OH	Racoon		12.3		12.3
AB Central Hotel	10	Central Hotel	HT	10.531321	76.219899	UG	XLPE	240	47	7	54
P8, AB Agro Bazar	G12	Ground		10.530807	76.219895	UG	XLPE	300			0
AB Agro Bazar	G13	Ground		10.530797	76.220654	UG	XLPE	300			0
G13	RMU31402	RMU		10.530761	76.220646	UG	XLPE	300			0
RMU31402	13	Agro	LT	10.530756	76.220664	UG	XLPE	300	140.21	5	145.21
P9	P10	Post		10.530809	76.221516	OH	Racoon		177.54		177.54
P10	G14	Ground		10.530814	76.22142	UG	XLPE	240			0
G14	G15	Ground		10.529275	76.221392	UG	XLPE	240			0
G15	4	Exchange 1	HT	10.529062	76.221863	UG	XLPE	240	237.46	7	244.46

From Map no	Map no	Pole/transformer/AB	Metering point	Latitude	Longitude	Cable	Cable type	Cable size (sq mm)	Mapping distance (m)	Loose distance (m)	Total distance (m)
G15	5	Exchange 2	HT	10.529062	76.221863	UG	XLPE	240	237.46	7	244.46
P10	9	Museum	LT	10.530829	76.221687	OH	Racoon		18.85		18.85
P10	ABL51404	AB		10.530897	76.223431	OH	Racoon				0
ABL51404	ABL51405	AB		10.530910	76.224284	OH	Racoon		284.47		284.47
ABL51405	G16	Ground		10.530589	76.224176	UG	XLPE	300			0
G16	G17	Ground		10.530093	76.224199	UG	XLPE	300			
G17	G18	Ground		10.529944	76.224188	UG	XLPE	300			
G18	G19	Ground		10.529764	76.224177	UG	XLPE	300			
G19	G20	Ground		10.529615	76.223911	UG	XLPE	300			
G20	G21	Ground		10.529547	76.223655	UG	XLPE	300			
G21	G22, 3	Co-operative Road	LT	10.529555	76.223553	UG	XLPE	300	202.48	7	209.48
ABL51405	P11	Post		10.531048	76.224375	OH	Racoon				
P11	P12, 14	Mana Line	LT	10.531945	76.22436	OH	Racoon		117.46		117.46
P12	P13	Post		10.532084	76.224351	OH	Racoon		15.41		15.41
P13	G23	Ground		10.532116	76.224258	UG	XLPE	300		5	5
G23	G24	Ground		10.532425	76.224301	UG	XLPE	300			
G24	6	Sougandhika	LT	10.532419	76.224316	UG	XLPE	300	47.05	7	54.05
P13	AB Navani	AB		10.532341	76.222739	OH	Racoon		178.72		178.72
AB Navani	12	Navani Holy View	LT	10.532599	76.222672	UG	XLPE	185	29.46	7	36.46
AB Navani	P14	Mana Line	LT	10.532444	76.221984	OH	Racoon		83.42		83.42
P14	AB KMP	AB		10.532354	76.221943	OH	Racoon		10.92		10.92
AB KMP	30	KMP Swapnapuri	LT	10.532223	76.221895	UG	XLPE	185	15.42	20	35.42
ABL51405	P15	Post		10.530937	76.224358	OH	XLPE				
P15	P16	Post		10.530953	76.22567	OH	XLPE		152.25		152.25
P16	AB Caza		LT	10.531038	76.225556	OH	XLPE		15.62		15.62
AB Caza	7	Cheloor Cazeblanka	LT	10.531311	76.225649	UG	XLPE	185	31.87	12	43.87

From Map no	Map no	Pole/transformer/ AB	Metering point	Latitude	Longitude	Cable	Cable type	Cable size (sq mm)	Mapping distance (m)	Loose distance (m)	Total distance (m)
P16	P17	Post		10.530955	76.226264	OH	Racoon				
P17	P18, 8	Southern	LT	10.530926	76.22625	OH	Racoon		68.57		68.57
P18	AB Atreya	AB		10.528705	76.226187	OH	Racoon		245.76		245.76
AB Atreya	RMU31403	RMU		10.528705	76.226680	UG	XLPE	300			0
RMU31403	16	Divya Ram Hospital (Atreya)	HT	10.528705	76.226680	UG	XLPE	300	53.96	7	60.96
AB Atreya	P19	Post		10.527482	76.226134	OH	Racoon		135.4		135.4
P19	AB Bishop Palace	AB		10.527476	76.226151	UG	XLPE	300	1.98		1.98
AB Bishop Palace	RMU 31404, 17	Bishop Palace	HT	10.527635	76.226238	UG	XLPE	300	20	7	27
P19	ABL51406	AB		10.527103	76.22612	OH	Racoon				0
ABL51406	AB BP, 28	Bishop Palace	LT	10.526115	76.226065	OH	Racoon		151.4		151.4
AB BP	P20	Post		10.525691	76.226041	OH	Racoon		46.97		46.97
P20	18	Kings fort	LT	10.525695	76.225917	OH	ABC		13.58		13.58
P20	P21	Post		10.525335	76.226022	OH	Racoon		39.43		39.43
P21	ABI51410	AB		10.524497	76.225966	OH	Racoon				0
P21	P22	Post		10.525432	76.226059	OH	Racoon				0
P22	ABL51407	AB		10.525533	76.226316	OH	Racoon				0
ABL51407	P23	Post		10.525941	76.227409	OH	Racoon				0
P23	P24	Post		10.526431	76.228472	OH	Racoon		297.96		297.96
P24	AB Sky Line	AB		10.526609	76.228458	UG	XLPE	300			0
AB Sky Line	G25	Ground		10.526875	76.228303	UG	XLPE	300			0
AB Sky Line	23	Skyline Garland	LT	10.526894	76.22833	UG	XLPE	300	57.34	7	64.34
P24	AB Soda varky, 20	Soda varky	LT	10.526630	76.228808	OH	Racoon		42.86		42.86
AB Soda varky	P25	Post		10.526696	76.229089	OH	Racoon		31.61		31.61

From Map no	Map no	Pole/transformer/ AB	Meterin g point	Latitude	Longitude	Cab le	Cable type	Cabl e size (sq mm)	Mappin g distanc e (m)	Loose distanc e (m)	Total distanc e (m)
P25	21	Sarayu Apartment	LT	10.527064	76.228926	OH	Racoon		44.44		44.44
P25	P26	Post		10.526895	76.229619	OH	Racoon				0
P26	P27	Post		10.527108	76.230063	OH	Racoon				0
P27	ABL51409	AB		10.52733	76.23044	OH	Racoon		164.27		164.27
ABL51409	AB Kollanur Oriental	AB		10.527431	76.230394	OH	Racoon		12.25		12.25
AB Kollanur Oriental	G26	Ground		10.527670	76.23025	UG	XLPE	300			0
G26	24	Kollanur Oriental	LT	10.527703	76.230158	UG	XLPE	300	41.49	40	81.49
ABL51409	P28	Post		10.527652	76.230830	OH	Racoon				0
P28	P29	Post		10.527749	76.230871	OH	Racoon				0
P29	P30	Post		10.527888	76.231176	OH	Racoon				0
P30	P31	Post		10.528096	76.231451	OH	Racoon		140.02		140.02
P31	ABI50409, 22	Panmukkumpilly Sastha Temple	LT	10.528261	76.231702	OH	Racoon		33.51		33.51
P21	ABL51408	AB		10.525272	76.225681	OH	Racoon				0
ABL51408	P31	Post		10.525176	76.22527	OH	Racoon				0
P31	P32	Post		10.524753	76.224435	OH	Racoon				0
P32	P33	Post		10.52467	76.224341	OH	Racoon		206.83		206.83
P33	P34	Post		10.524940	76.224318	OH	Racoon		32.36		32.36
P34	AB CTR	AB		10.525019	76.224222	OH	Racoon		14.86		14.86
AB CTR	19	Cheloor Tudoor Rose	LT	10.525106	76.224062	UG	XLPE	300	19.98	7	26.98
P34	P35	Post		10.525685	76.224243	OH	Racoon		82.58		82.58
P35	AB Gayathri	AB Gayathri		10.525663	76.224283	OH	Racoon		6.04		6.04
AB Gayathri	26	Gayathri Apartment	LT	10.525638	76.224343	UG	XLPE	300	7.13	20	27.13
P35	P36	Post		10.526207	76.224215	OH	Racoon				0

From Map no	Map no	Pole/transformer/ AB	Metering point	Latitude	Longitude	Cable	Cable type	Cable size (sq mm)	Mapping distance (m)	Loose distance (m)	Total distance (m)
P36	25	Keeramkulangara	LT	10.526226	76.224118	OH	Racoon		66.33		66.33
P33	P37	Post		10.524628	76.224362	OH	Racoon				0
P37	P38	Post		10.524441	76.224230	OH	Racoon		34.27		34.27
P38	AB Sreyas	AB		10.524423	76.224250	OH	Racoon		2.96		2.96
AB Sreyas	G27	Ground		10.524223	76.224260	UG	XLPE	300			0
G27	27	Sreyas Apartment	LT	10.524157	76.224478	UG	XLPE	300	50.68	7	57.68
P38	G28	Ground		10.524239	76.22398	UG	XLPE	300	35.33		35.33
G28	G29	Ground		10.523659	76.222731	UG	XLPE	300			0
G29	G30	Ground		10.523352	76.221706	UG	XLPE	300			0
G30	RMU31405	RMU		10.523778	76.221623	UG	XLPE	300			0
RMU31405	29	Forus Apartment	LT	10.523746	76.221569	UG	XLPE	300	323.19	7	330.19

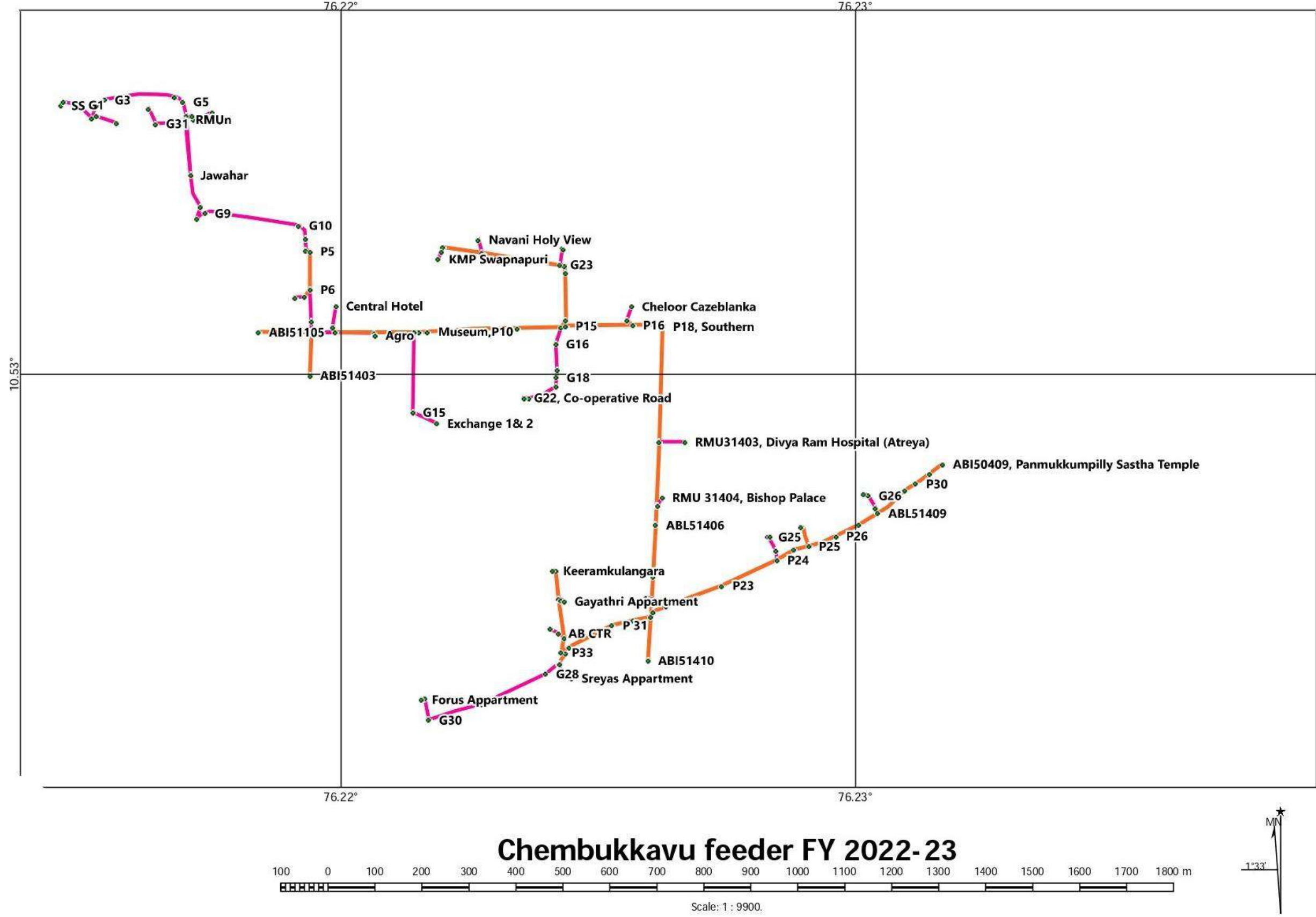

Figure 3: Chembukkavu feeder

3 EAST FORT FEEDER

The following table shows the 11-kV line distance in the East fort feeder.

Table 17: HT line distance – East fort feeder

From Map no	Map no	Pole/transformer/A B	Metering point	Latitude	Longitude	Cable	Cable size (sq mm)	Mapping distance (m)	Loose distance (m)	Total distance (m)
SS	2P	Substation feeder		10.535185	76.214764	UG	300		25	25
2P	G1	Ground		10.534967	76.215221	UG				0
G1	G2	Ground		10.533556	76.215243	UG				0
G2	G2-1	Ground		10.533400	76.21523	UG				0
G2-1	G2-2	Ground		10.53342	76.21589	UG				0
G2-2	G2-3	Ground		10.53323	76.21627	UG				0
G2	G3	Ground		10.532946	76.216472	UG				0
G3	P1	Post (2 Pole)		10.532962	76.216747	UG	300		10	10
P1	G4	Ground		10.532924	76.217225	UG				0
G4	G4-1	Ground		10.53312	76.21738	UG				0
G4-1	G4-2	Ground		10.53287	76.2191	UG				0
G4-2	G4-3	Ground		10.53274	76.21957	UG				0
G4-3	P2	Post (2 Pole)		10.532900	76.219594	UG	300		10	10
P2	G4-4	Ground		10.53283	76.21958	UG				0
G4-4	G5	Ground		10.532100	76.224381	UG				0
G5	G6	Ground		10.531829	76.226241	UG				0
G6	P3	Post(2 Pole)		10.530592	76.226214	UG	300		10	10
P3	G6-1	Ground		10.529120	76.22618	UG				0
G6-1	AB1	ABL 51702		10.521957	76.225890	UG	300	2590	55	2645
AB1	P4	Post		10.521644	76.225868	OH		35.07		35.07
P4	AB2	ABI50104		10.521295	76.225861	OH		38.45		38.45
ABI50104	G12	Ground		10.521256	76.225075	UG				0

From Map no	Map no	Pole/transformer/A B	Metering point	Latitude	Longitude	Cable	Cable size (sq mm)	Mapping distance (m)	Loose distance (m)	Total distance (m)
G12	RMU1/22	RMU31708, East Avenue	LT	10.521319	76.225052	UG	300	93.55		93.55
RMU1	G13	Ground		10.521291	76.225548	UG				0
G13	RMU2/15	RMU31709, Navya Bakery	HT	10.521329	76.225487	UG	300	57.58		57.58
P4	AB3	ABL51705		10.521868	76.225349	OH		64.38		64.38
ABL51705	10	Sun Tower	LT	10.522057	76.225372	UG	300	21.06	7	28.06
ABL51705	32	E P Jose Commercial Building	LT	10.521747	76.225340	OH		13.42		13.42
ABL51705	G7	Ground		10.521932	76.225158	UG				0
G7	G8	Ground		10.522397	76.224891	UG				0
G8	P16	ABL Selex Mall		10.522444	76.224764	UG				0
P16	Selex Mall			10.522863	76.224550	UG	300	150.01	7	157.01
ABL51705	AB6	ABL 51706		10.521605	76.224235	OH		125.85		125.85
ABL 51706	G11	Ground		10.522369	76.224089	UG				0
G11	11	Sindhooram Apartment	LT	10.522313	76.223704	UG	300	131.97	5	136.97
ABL 51706	P11	Post		10.521541	76.223908	OH		36.49		36.49
P11	1	Thomson Casa	LT	10.521514	76.223921	UG	300	3.31	10	13.31
P11	P12, 12	Pallikulam	LT	10.521295	76.22264	OH		141.44		141.44
P12	P13	Post		10.521248	76.221944	OH		76.36		76.36
P13	P23,33	AB-Chaldian, Chaldian	LT	10.521223	76.22196	OH		3.52		3.52
P13	P13-1	Post		10.521246	76.221521	OH				0
P13-1	34	Brothers Lane	LT	10.520909	76.221433	OH		85.79		85.79
P13	P14	Post		10.521225	76.220351	OH				0
P14	P14-1, 13	Sakthan Tower	LT	10.521234	76.220207	OH		190.14		190.14
P14-1	AB7	ABL51707		10.521199	76.219330	OH		92.24		92.24
AB7	P15	Post		10.521578	76.218757	OH				0

From Map no	Map no	Pole/transformer/A B	Metering point	Latitude	Longitude	Cable	Cable size (sq mm)	Mapping distance (m)	Loose distance (m)	Total distance (m)
P15	P15-1, 14	Post/Puthenpally	LT	10.521453	76.218811	OH		134.02		134.02
P15-1	RMU7,17	RMU31707, P I Babu	LT	10.521527	76.218937	UG	300	24.38		24.38
ABL51707	AB8	ABI 51611		10.521603	76.219432	UG		44.99		44.99
ABL 51702	P5	Post		10.522575	76.225910	OH		74.53		74.53
P5	AB4/04	ABL51704/Spoon (City Castle)	LT	10.522825	76.225582	OH		40.88		40.88
ABL51704	G9	Ground		10.522925	76.225207	UG	300			0
G9	6,5	Reliance-2(City Palace-2), Reliance-1(City Palace-1)	LT	10.522600	76.225175	UG	300	75.24	25	100.24
ABL51704	P6	Post		10.522925	76.22507	OH				0
P6	P7	Post		10.523061	76.225125	OH		54.48		54.48
P7	P21, 24	AB- Fort Street, Fort Street	LT	10.523125	76.225360	OH		18.69		18.69
P21	7	Fort City	LT	10.523202	76.225611	OH		28.76		28.76
P7	P17	AB- Bharathakshemam		10.523251	76.224112	OH		122.07		122.07
P17	8	Bharathakshemam	LT	10.523825	76.223926	UG	300	66.68	5	71.68
AB- Bharathakshe mam	P8	Post		10.523121	76.222649	OH		161.71		161.71
P8	P18	AB-Emmatty Tower		10.522751	76.222719	OH		40.14		40.14
P18	9	Emmatty Tower	LT	10.522778	76.222897	UG	400	21.45	5	26.45
P18	P19	AB-Candela		10.522713	76.222713	OH		5.83		5.83
P19	RMU3	RMU31706		10.522709	76.222770	UG	185			0
RMU3	16	Candela Apartment	LT	10.522545	76.222937	UG	185	31.47	6	37.47
P8	P20	AB St-Thomas		10.523305	76.220894	OH		199.2		199.2
P20	25	St-Thomas College	HT	10.523294	76.220941	UG	300	11.02	5	16.02
AB St-Thomas	26/ABI 51604	Iyyunni	LT	10.523312	76.220588	OH		27.82		27.82

From Map no	Map no	Pole/transformer/A B	Metering point	Latitude	Longitude	Cable	Cable size (sq mm)	Mapping distance (m)	Loose distance (m)	Total distance (m)
P5	P22	AB-Seemas		10.522861	76.226168	OH		49.98		49.98
P22	2	Seemas	HT	10.523156	76.22624	UG	300	33.57	20	53.57
P22	P10	Post		10.522819	76.226316	OH		16.98		16.98
P10	23	Kings Way Project	LT	10.523318	76.226419	UG	300	60.18	30	90.18
P10	AB5	ABL 51708		10.522765	76.226348	OH		6.27		6.27
ABL 51708	3	Honest Bakery	LT	10.522603	76.226276	OH		19.58		19.58
ABL 51708	RMU4, 20	RMU31703, Angelic Tower	LT	10.522515	76.226922	UG	300	70.72	10	80.72
ABL 51708	G10	Ground		10.522163	76.227959	UG				0
G10	RMU5, 19	RMU 31704, Lorde Pally	HT	10.522281	76.227955	UG	300	200.15		200.15
RMU5	G10	Ground		10.522163	76.227959	UG				0
G10	RMU6	RMU31705		10.52219	76.227216	UG				0
RMU6	18	East Fort Tower	LT	10.522085	76.227209	UG	300	111.34		111.34
P5	AB9	ABL51703		10.524137	76.225960	OH		170.23		170.23
ABL51703	RMU8	RMU31701		10.52449	76.225809	UG	300	51.38		51.38
RMU8	30/31	E Forts Unlimited (HT), E Forts (LT)	HT, LT	10.524479	76.225461	UG	150	42.91	30	72.91
RMU8	RMU9	RMU31702		10.524017	76.225757	UG	300			
RMU9	21	Rappai & Sons	LT	10.524231	76.225612	UG	300	94.61	210	304.61

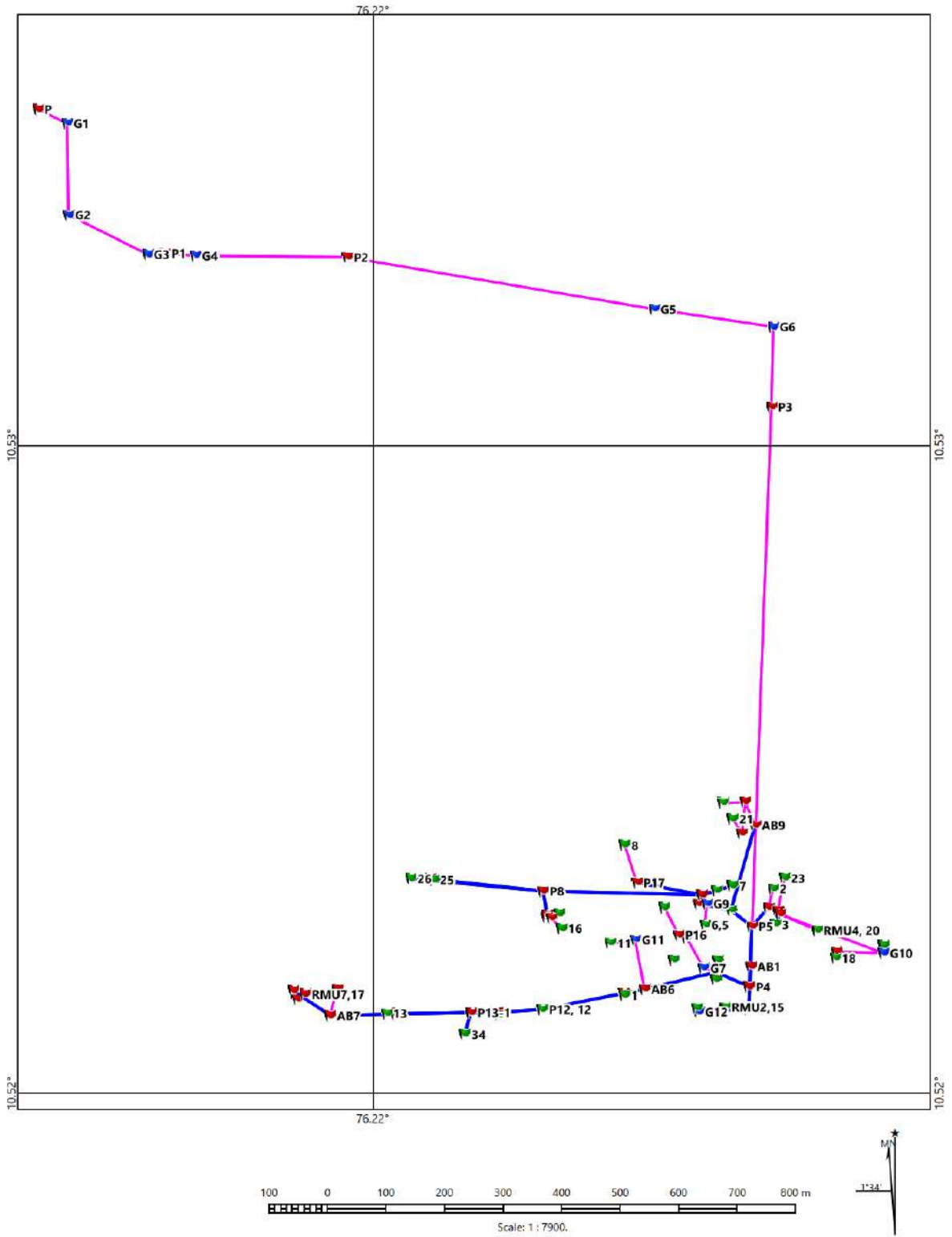

Figure 4: East fort feeder

4 **JUBILEE MISSION FEEDER**

Jubilee mission feeder is the only dedicated feeder inside the DISCOM. The supply provided from the 66-kV substation in the Aswini. The detail of mapping of the feeder is given in the table below.

Table 18: HT line distance – Jubilee mission feeder

From Map no	Map no	Pole/transformer/ AB	Metering point	Latitude	Longitude	Cable	Cable type	Cable size (sq mm)	Mapping distance (m)	Loose distance (m)	Total distance (m)
SS		Substation feeder		10.535185	76.214764	UG	XLPE	300		10	10
SS	P1	Post		10.535247	76.214725	UG	XLPE	300			0
P1	G1	Ground		10.535184	76.214900	UG	XLPE	300			0
G1	G2	Ground		10.534978	76.215035	UG	XLPE	300			0
G2	G3	Ground		10.533455	76.215075	UG	XLPE	300			0
G3	G4	Ground		10.533382	76.216132	UG	XLPE	300			0
G4	G5	Ground		10.533006	76.216531	UG	XLPE	300			0
G5	G6	Ground		10.532984	76.217128	UG	XLPE	300			0
G6	G7	Ground		10.533180	76.217414	UG	XLPE	300			0
G7	G8	Ground		10.532808	76.219361	UG	XLPE	300			0
G8	G9	Ground		10.532399	76.222235	UG	XLPE	300			0
G9	G10	Ground		10.531810	76.226219	UG	XLPE	300			0
G10	G11	Ground		10.531020	76.226247	UG	XLPE	300			0
G11	G12	Ground		10.530896	76.226196	UG	XLPE	300			0
G12	G13	Ground		10.527708	76.226094	UG	XLPE	300			0
G13	G14	Ground		10.525349	76.225990	UG	XLPE	300			0
G14	G15	Ground		10.523079	76.225892	UG	XLPE	300			0
G15	G16	Ground		10.521214	76.225809	UG	XLPE	300			0
G16	G17	Ground		10.520915	76.225789	UG	XLPE	300			0
G17	01, 02 - Jubilee Mission	Jubilee Mission	HT	10.520737	76.226735	UG	XLPE	300	2806.34	5	2811.34

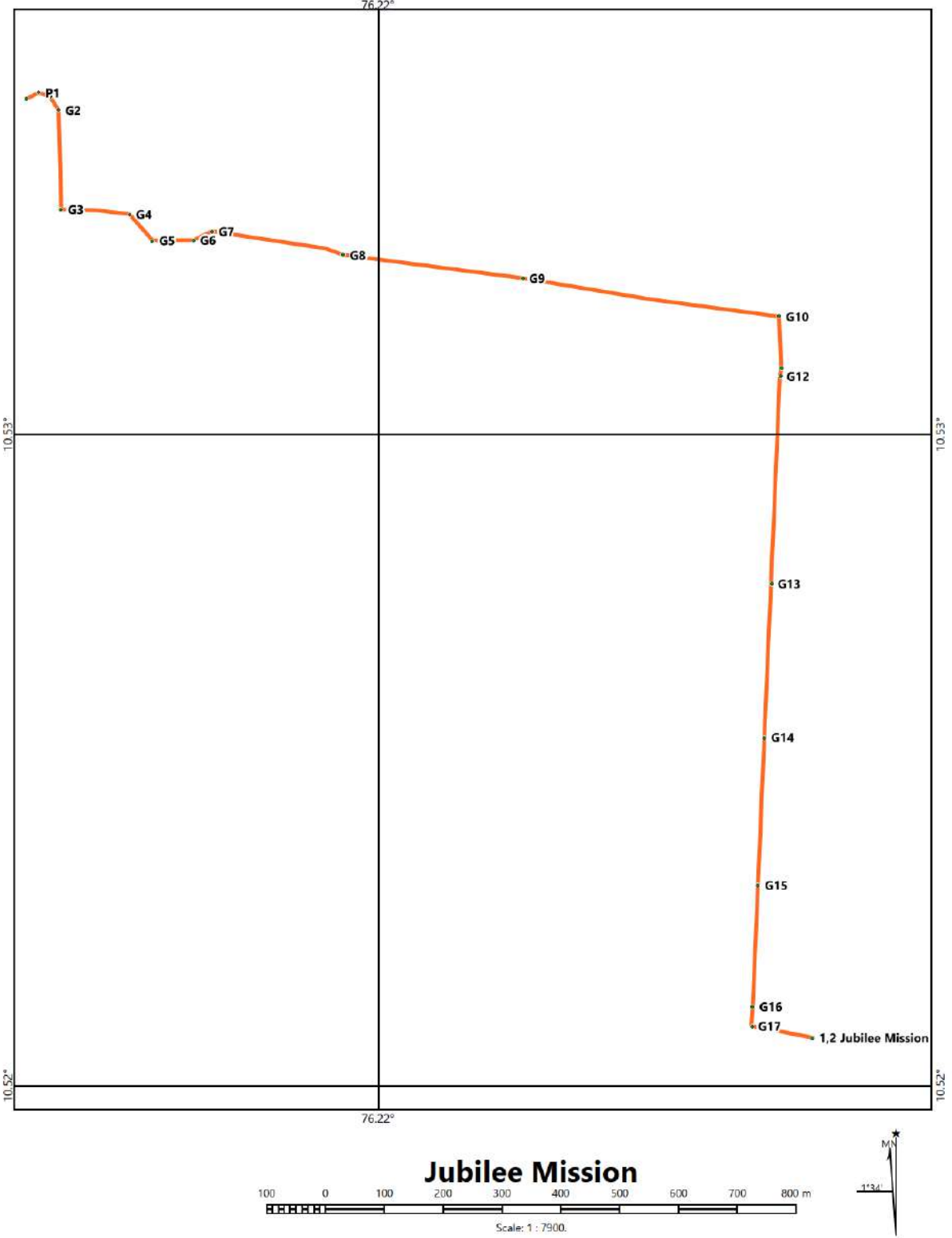

Figure 5: Jubilee mission feeder

5 KOORKANCHERY FEEDER

The following table shows the 11-kV line distance in the Koorkanchery feeder.

Table 19: HT line distance – Koorkanchery feeder

From Map no	Map no	Pole/transformer/AB	Metering point	Latitude	Longitude	Cable	Cable size (sq mm)	Mapping distance (m)	Loose distance (m)	Total distance (m)
	S-S	Substation feeder		10.517135	76.219407					
S-S	P1	Post		10.517229	76.219394	UG	300	10.74		10.74
P1	P2	Post		10.516079	76.217681	OH		216.87		216.87
P2	RMU1	RMU-30301		10.515940	76.217541	UG	300	21.71		21.71
RMU1	G11	Ground		10.516020	76.21746	UG	300	12.85		12.85
G11	RMU2	RMU-30201		10.516002	76.217265	UG	300	21.57	10	31.57
RMU1	G12	Ground		10.5159	76.2176	UG	300	8.32		8.32
G12	G1	Ground		10.515281	76.217852	UG	300		5	5
G1	G2	Ground		10.514711	76.217816	UG	300			0
G2	G13	Ground		10.51448	76.21773	UG	300			0
G13	G14	Ground		10.51412	76.2175	UG	300	210.82		210.82
G14	G3	Ground		10.513983	76.217229	UG	300	33.69		33.69
G3	P3	Post		10.513975	76.216334	UG	300	98.52	3	101.52
P3	P4	Post		10.513948	76.215683	UG	300	69.7	2	71.7
P4	G15	Ground		10.51401	76.21548	UG	300	23.96		23.96
G15	G16	Ground		10.51409	76.21315	UG	300	254.48		254.48
G16	G17	Ground		10.51393	76.21249	UG	300	74.71		74.71
G17	AB1, 1	ABL-50302, Commercial	LT	10.513734	76.211497	UG	300	112.76	15	127.76
AB1	G4	Ground		10.513728	76.211744	UG	300	30.74		30.74
G4	2	Casino	HT	10.513226	76.211783	UG	240	57.28	10	67.28
AB1	P5	Post		10.513803	76.210648	OH		92.93		92.93
P5	AB2	ABI-50208		10.513877	76.210741	OH		13.06		13.06
P5	P23	Post		10.51373	76.21073	OH		12.44		12.44
P23	P6	Post		10.513250	76.210612	OH		54.71		54.71
P6	G5	Ground		10.513396	76.209860	UG	300			0
G5	3	Smart Centre	LT	10.513500	76.209873	UG	300	98.37	5	103.37

From Map no	Map no	Pole/transformer/AB	Metering point	Latitude	Longitude	Cable	Cable size (sq mm)	Mapping distance (m)	Loose distance (m)	Total distance (m)
P6	P7	Post		10.512421	76.210760	OH		93.2		93.2
P7	G6	Ground		10.512229	76.210821	UG	300		10	10
G6	4	Sree Sailam	LT	10.511936	76.210050	UG	300	115.91		115.91
P8	P9	Post		10.510568	76.211192	OH		213.63		213.63
P9	P9-1	Post		10.510568	76.211075	OH		12.81		12.81
P9-1	5	Metro	HT	10.510538	76.210265	UG	185	94.41	10	104.41
P9	P10	Post		10.510099	76.211150	OH		52.08		52.08
P10	RMU3	RMU-30303		10.509968	76.211192	UG	300		10	10
RMU3	26	CK Plaza	LT	10.510005	76.211451	UG	300	43.85	10	53.85
P10	6	Alumkulam	LT	10.509821	76.211194	OH		27.23		27.23
6	G7	Ground		10.508329	76.211218	UG	240			0
G7	10	Thankamani	LT	10.508311	76.210904	UG	240	198.69		198.69
10	P11	Post		10.508220	76.210012	OH		98.16		98.16
P11	P11-1	Post		10.508349	76.210006	OH		14.28		14.28
P11-1	8	Skyline	LT	10.508474	76.210213	UG	300	26.54	5	31.54
P11	P12	Post		10.508144	76.209292	OH				0
P12	P13	Post		10.508169	76.208953	OH		116.47		116.47
P13	P13-1	Post		10.508270	76.208858	OH		15.16		15.16
P13-1	9	Love-Shore	LT	10.508759	76.208660	UG	150	58.27	50	108.27
P13	7	Kaja	LT	10.508194	76.208521	OH		47.37		47.37
6	P14	Post		10.508329	76.211218	OH		165.57		165.57
P14	P15	Post		10.507600	76.211206	OH		80.78		80.78
P15	RMU4	RMU-30304		10.507486	76.211638	UG	300		30	30
RMU4	11	Mannanthara Agencies	LT	10.507486	76.211638	UG	300	52.33	5	57.33
P15	P16	Post		10.505500	76.211316	OH		233.02		233.02
P16	P17	Post		10.505174	76.211337	OH		36.13		36.13
P17	15	Smart City	LT	10.505162	76.211205	OH		14.51		14.51
15	24	I-Vision	HT	10.504276	76.211012	UG	300	136.81	5	141.81
P17	P18	Post		10.504101	76.211411	OH		118.96		118.96
P18	17	Hi-Life	LT	10.504280	76.212928	UG	300	167.51	5	172.51
P18	AB3	ABL-50310		10.503620	76.211479	OH		53.48		53.48
AB3	RMU5	RMU-30306		10.503614	76.211526	UG	300		15	15
RMU5	25	Shangri-La-Fortune	LT	10.503609	76.211899	UG	300	48.07	5	53.07

From Map no	Map no	Pole/transformer/AB	Metering point	Latitude	Longitude	Cable	Cable size (sq mm)	Mapping distance (m)	Loose distance (m)	Total distance (m)
AB3	P19	Post		10.503380	76.211524	OH				0
P19	AB4	ABL-50311		10.503186	76.211440	OH				0
AB4	16	Sun City	LT	10.503186	76.211440	OH		50.8		50.8
P16	P20	Post		10.505332	76.210463	OH		95.21		95.21
P20	P21	Post		10.505025	76.210402	OH				0
P21	13	Kanjirangadi	LT	10.503952	76.209568	OH		184.34		184.34
13	P22	Post		10.502503	76.208480	OH				0
P22	AB5	AB		10.502738	76.208187	OH		209.19		209.19
AB5	G8	Ground		10.502661	76.207606	UG	300			0
G8	14	Q-Apartment	LT	10.502879	76.207473	UG	300	92.34	5	97.34
P20	12	Kinar	LT	10.505326	76.210208	OH		27.92		27.92
P5	18	Veterinary	LT	10.513811	76.210537	OH		12.18		12.18
18	19	Dee Pee Plaza	LT	10.513914	76.209943	OH		66.01		66.01
19	P21	Post		10.514150	76.208370	OH				174.15
P21	20	Dhanya	LT	10.514088	76.208363	OH				6.9
P21	P21-1	Post		10.514143	76.208116	OH		27.81		27.81
P21-1	22,23	Railway	HT,HT	10.515153	76.208195	UG	185	117.75	10	127.75
P21-1	RMU6	RMU-30302		10.514273	76.207036	UG	300	119.09	10	129.09
20	AB6	ABL-50308		10.513104	76.208221	OH		109.95		109.95
AB6	21	Ice Plant	LT	10.512922	76.208477	OH		34.5		34.5
AB6	G9	Ground		10.511743	76.207351	UG	300			0
G9	G10	Ground		10.508494	76.206378	UG	300			0
G10	RMU7	RMU-30305		10.508207	76.207788	UG	300	718.81		718.81
RMU7	27	Forus Apartment	LT	10.508007	76.207782	UG	150	22.13		22.13

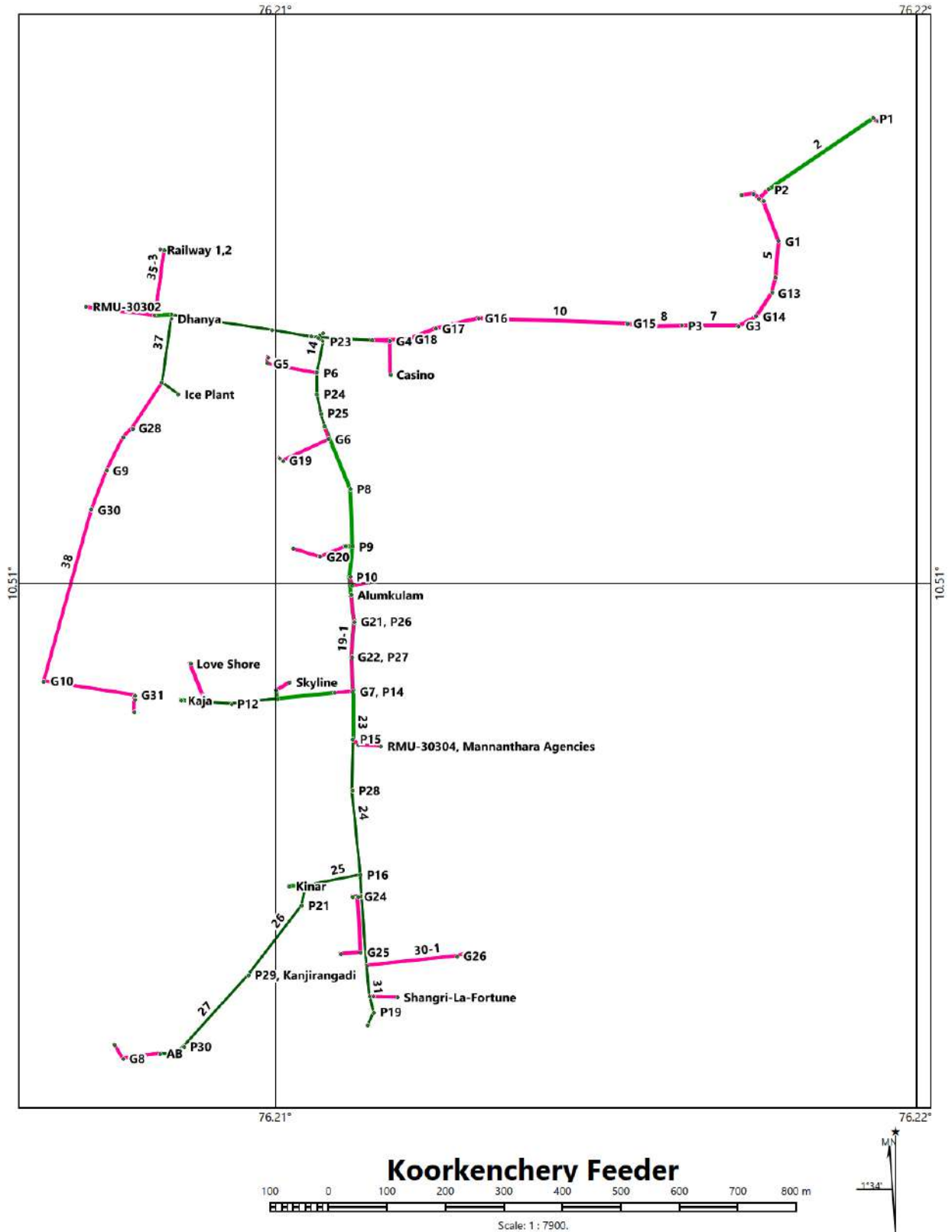

Figure 6: Koorkanchery feeder

6 RAMANILAYAM FEEDER

The following table shows the 11-kV line distance in the Ramanilayam feeder.

Table 20: HT line distance – Ramanilayam feeder

From Map no	Map no	Pole/transformer/ AB	Metering point	Latitude	Longitude	Cable	Cable type	Cable size (sq mm)	Mapping distance (m)	Loose distance (m)	Total distance (m)
	S-S	Substation feeder		10.535182	76.21455						
S-S	P1	Post		10.535115	76.214826	UG	XLPE	300		37	37
P1	P2	Post		10.534981	76.215004	UG	XLPE	300	10	15	25
P2	ABL51102	ABL51102		10.534982	76.215185	OH	Racoon				0
ABL51102	P3	Post		10.533549	76.215227	OH	Racoon				0
P3	P4	Post		10.53397	76.215342	OH	Racoon		202.2		202.2
P4	1	Stadium West	LT	10.533257	76.215292	OH	Racoon		10.33		10.33
P4	P5	Post		10.533420	76.215841	OH	Racoon				
P5	P6	Post		10.533401	76.216003	OH	Racoon				
P6	P7	Post		10.533325	76.216275	OH	Racoon				
P7	P8	Post		10.532954	76.216447	OH	Racoon				
P8	2, ABL51103	Stadium East	LT	10.532928	76.21671	OH	Racoon		189.16		189.16
ABL51103	G1	Ground		10.532945	76.216659	UG	XLPE	300			0
G1	23	Indoor Stadium	HT	10.532891	76.216673	UG	XLPE	300		10.02	10.02
ABL51103	G2	Ground		10.532986	76.217108	UG	XLPE	300			0
G2	P9	Post		10.531025	76.217042	UG	XLPE	300		192.4	192.4
P9	P10	Post		10.530901	76.217115	OH	Racoon				0
P10	P11	Post		10.530852	76.217868	OH	Racoon			96.89	96.89
P11	ABL51104	ABL51104		10.530848	76.218143	OH	Racoon				0
ABL51104	P12	Post		10.530847	76.218303	OH	Racoon			49.2	49.2
P12	AB Ramanilayam	AB		10.531074	76.2183	OH	Racoon				0

From Map no	Map no	Pole/transformer/ AB	Metering point	Latitude	Longitude	Cable	Cable type	Cable size (sq mm)	Mapping distance (m)	Loose distance (m)	Total distance (m)
AB Ramanilayam	3	Ramanilayam	LT	10.531143	76.218297	OH	Racoon			32.75	32.75
P12	ABI51105	ABI51105		10.530836	76.218591	OH	Racoon			12.47	12.47
P11	ABL51106	ABL51106		10.529097	76.217916	OH	Racoon		196.57		196.57
ABL51106	AB Pulimoottil	AB		10.529117	76.217892	OH	Racoon		3.43		3.43
AB Pulimoottil	4	Pulimoottil	HT	10.529174	76.217798	UG	XLPE	300	12.7	25	37.7
ABL51106	P13	Post		10.528838	76.217967	OH	Racoon		29.19		29.19
P13	AB Kaliyath, Chungath	AB		10.528519	76.218008	OH	Racoon		35.26		35.26
AB Chungath	11	Chungath Jewellery	HT	10.528557	76.217719	UG	XLPE	150	30.29	20	50.29
AB Kaliyath	10	Kaliyath	LT	10.528383	76.217532	UG	XLPE	150	52.72		52.72
AB Kaliyath	AB-YMCA	AB		10.528555	76.218122	OH	Racoon		14.61		14.61
AB-YMCA	8	YMCA	HT	10.528522	76.218248	UG	XLPE	150	14.27	56	70.27
AB Kaliyath	AB Chiriyam Kandath	AB		10.528363	76.218016	OH	Racoon		12.03		12.03
AB Chiriyam Kandath	12	Chiriyam Kandath	LT	10.528236	76.217919	UG	XLPE	150	17.61	28	45.61
AB Chiriyam Kandath	AB Kalyan	AB		10.528002	76.218023	OH	Racoon		41		41
AB-YMCA	9	Josco	HT	10.528522	76.218248	UG	XLPE	150	14.27	56	70.27
AB Kalyan	RMU31103, 14, 13	Kalyan Silks	HT	10.527997	76.217974	UG	XLPE	185	6.7	15	21.7
AB Kalyan	AB Vrindhavan	AB		10.5277180	76.2180790	OH	Racoon		30.77		30.77
AB Vrindhavan	G3	Ground		10.527808	76.218060	UG	XLPE	150			0
G3	G4	Ground		10.527792	76.217670	UG	XLPE	150			0
G4	15	Vrindhavan Apartment	LT	10.527757	76.217654	UG	XLPE	150	57.14	5	62.14

From Map no	Map no	Pole/transformer/ AB	Metering point	Latitude	Longitude	Cable	Cable type	Cable size (sq mm)	Mapping distance (m)	Loose distance (m)	Total distance (m)
AB Vrindhavan	P13-1, 25	AB Josco, AB Kalanikethan, Kalanikethan	LT	10.527250	76.218086	OH	Racoon		51.77		51.77
P13-1	G5	Ground		10.526945	76.218110	UG	XLPE	185			0
G5	G6	Ground		10.526774	76.218067	UG	XLPE	185			0
G6	19	New Josco	HT	10.526655	76.218267	UG	XLPE	185	81.87	22	103.87
P13-1	P14	Post		10.526928	76.218102	OH	Racoon				0
P14	P15	Post		10.526621	76.218002	OH	Racoon		72.13		72.13
P15	P16, 16	Swapana Theatre	LT	10.526400	76.217896	OH	Racoon		24.42		24.42
P16	ABL51107	AB Kollanur		10.526172	76.217769	OH	Racoon		31.38		31.38
AB Kollanur	24	Kollanur	LT	10.526363	76.217829	UG	XLPE	150	22.83	5	27.83
ABL51107	P17	Post		10.525925	76.217624	OH	Racoon				
P17	P18	Post		10.52568	76.217467	OH	Racoon		63.62		63.62
P18	21	Paremekkavu(Neeranjali)	LT	10.525591	76.217623	OH	Racoon		20.97		20.97
P18	AB Statue& Alukkas, 17	Statue	LT	10.525351	76.217298	OH	Racoon		37.49		37.49
AB Statue	P19	Post		10.525196	76.217228	OH	Racoon		21.85		21.85
P19	AB Paramekavu Temple	AB		10.524878	76.217206	OH	Racoon		36.2		36.2
AB Pt	G7	Ground		10.524458	76.217412	UG	XLPE	300			0
G7	G8	Ground		10.524189	76.217556	UG	XLPE	300			0
G8	G9	Ground		10.524185	76.217676	UG	XLPE	300			0
G9	20	Paramekavu Temple	LT	10.523848	76.217592	UG	XLPE	300	134.32		134.32
AB PT	P20	Post		10.524444	76.216941	OH	Racoon				0
P20	ABI51108	Post		10.523784	76.216893	OH	Racoon		128.57		128.57
AB Statue	G10	Ground		10.525409	76.217312	UG	XLPE	300			0

From Map no	Map no	Pole/transformer/ AB	Metering point	Latitude	Longitude	Cable	Cable type	Cable size (sq mm)	Mapping distance (m)	Loose distance (m)	Total distance (m)
G10	G11	Ground		10.525497	76.217342	UG	XLPE	300			0
G11	G12	Ground		10.525525	76.217061	UG	XLPE	300			0
G12	18	Alukkas	LT	10.526008	76.217048	UG	XLPE	300	88.82	20	108.82
P13	AB BVB	AB		10.528943	76.21796	OH	Racoon		14.85		14.85
AB BVB	RMU31102	RMU		10.528833	76.217238	UG	XLPE	150			
G9	28	Paramekavu SBI	HT	10.523848	76.217592	UG	XLPE	300	134.32		134.32
RMU31102	27	Bharatiyar Vidhya Kendra	HT	10.528617	76.216965	UG	XLPE	150	138.13	10	148.13
AB BVB	AB SNDP	AB		10.528883	76.217151	OH	Racoon		82.58		82.58
AB SNDP	RMU31101, 26	SNDP	LT	10.528929	76.217222	UG	XLPE	185	7.22	20	27.22
AB SNDP	P21	Post		10.528919	76.216847	OH	Racoon		35.26		35.26
P21	AB150802	AB		10.529136	76.216338	OH	Racoon		61.17		61.17
P21	P22	Post		10.528642	76.216753	OH	Racoon				0
P22	P23	Post		10.528149	76.216669	OH	Racoon		87.42		87.42
P23	AB Capital Legend	AB		10.528101	76.216744	OH	Racoon		8.69		8.69
AB Capital Legend	7	Capital Legend	LT	10.528040	76.216870	UG	XLPE	150	15.35	10	25.35
ABL51106	G13	Ground		10.528943	76.21796	UG	XLPE	150			0
G13	G14	Ground		10.528820	76.216780	UG	XLPE	150			0
G14	G15	Ground		10.527667	76.216618	UG	XLPE	150			0
G15	AB ESI, 5	ESI	LT	10.527679	76.216584	UG	XLPE	150	279.1	5	284.1
AB ESI	P24	Post		10.527667	76.216618	OH	Racoon				0
P24	P24-1	Post		10.527733	76.216695	OH	Racoon				0
P24-1	AB Capital City	AB		10.527742	76.216957	OH	Racoon		43.57		43.57
AB Capital City	22	Capital City	LT	10.527424	76.216993	UG	XLPE	150	36.47	5	41.47

From Map no	Map no	Pole/transformer/ AB	Metering point	Latitude	Longitude	Cable	Cable type	Cable size (sq mm)	Mapping distance (m)	Loose distance (m)	Total distance (m)
AB ESI	P24	Post		10.527667	76.216618	OH	Racoon				0
P24	P25	Post		10.527478	76.21657	OH	Racoon				0
P25	AB Perinchery	AB		10.527403	76.216597	OH	Racoon		33.12		33.12
AB Perinchery	6	Perinchery	LT	10.527259	76.216628	UG	XLPE	185	24.13	44	68.13

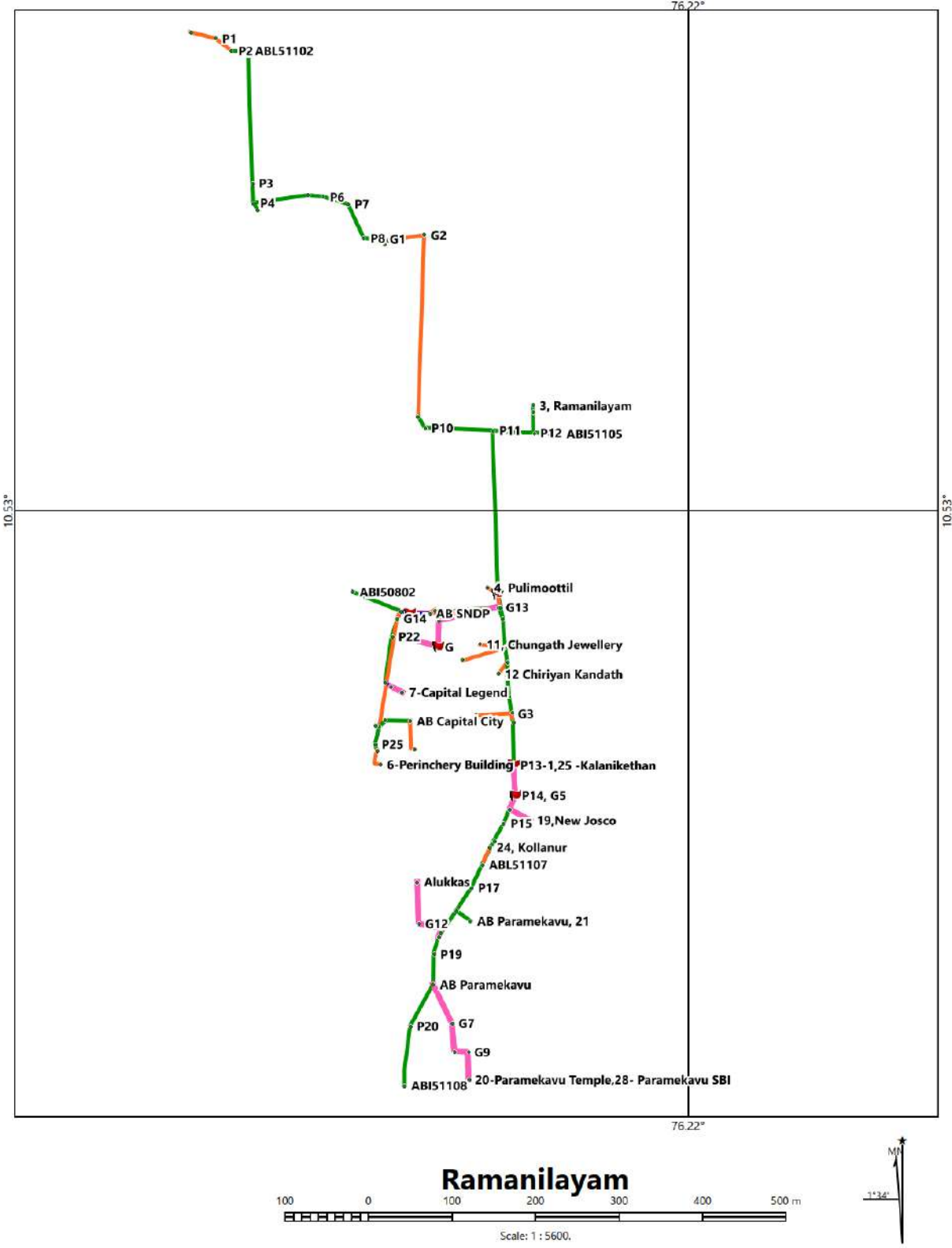

Figure 7: Ramanilayam feeder

7 SHORNUR ROAD FEEDER

The following table shows the 11-kV line distance in the Shornur road feeder

Table 21: HT line distance – Shornur road feeder

From Map no	Map no	Pole/transformer/ AB	Metering point	Latitude	Longitude	Cable	Cable type	Cable size (sq mm)	Mapping distance (m)	Loose distance (m)	Total distance (m)
ss		Substation		10.535032	76.214680						
SS	2P	Post		10.535226	76.214462	UG	XLPE	300			0
2P	G1	Ground		10.535310	76.214458	UG	XLPE	300			0
G1	ABL51502	AB		10.535327	76.213772	UG	XLPE	300	95.79	30	125.79
ABL51502	RMU31501, 35-Bismi	RMU31501, Bismi	HT	10.535520	76.213630	UG	XLPE	300	26.41	3	29.41
RMU31501	36- Bismi	Bismi	LT	10.535688	76.213811	UG	XLPE	300	27.16	20	47.16
RMU31501	G2	Ground		10.535438	76.213605	UG	XLPE	300			0
G2	G3	Ground		10.535432	76.213177	UG	XLPE	300			0
G3	RMU31502, 45-Pranavam Apartment	Pranavam Apartment	LT	10.535874	76.213136	UG	XLPE	300	111		111.04
RMU31502	G4	Ground		10.536289	76.213188	UG	XLPE	185			0
G4	RMU31503	RMU		10.536289	76.213296	UG	XLPE	185			0
RMU31503	46 - Top Orchid Apartment	Top Orchid Apartment	LT	10.536466	76.213430	UG	XLPE	185	85.83	30	115.83
ABL51502	P3	Post		10.535355	76.213445	OH	Racoon		36.38		36.38
P3	G7	Ground		10.535344	76.213345	UG	XLPE	300			0
G7	G8	Ground		10.534936	76.213325	UG	XLPE	300			0
G8	G9	Ground		10.534944	76.213137	UG	XLPE	300			0
G9	01- Sree Hari Apartments	Sree Hari Apartments	LT	10.534460	76.213069	UG	XLPE	300	128.59	10	138.59
P3	P1	Post		10.535361	76.213138	OH	Racoon		32.88		32.88

From Map no	Map no	Pole/transformer/ AB	Metering point	Latitude	Longitude	Cable	Cable type	Cable size (sq mm)	Mapping distance (m)	Loose distance (m)	Total distance (m)
P1	AB-Sree	AB-Sree Lakshmi		10.535280	76.213127	OH	Racoon		6.33		6.33
AB-Sree	2-Sreelakshmi Silks	Sreelakshmi Silks	LT	10.535189	76.213059	UG	XLPE	150	12.52	40	52.52
P1	P2	Post		10.535441	76.213146	OH	Racoon				0
P2	AB-Daffodils	AB		10.536055	76.213150	OH	Racoon		79.58		79.58
AB-Daffodils	G5	Ground		10.536081	76.213142	UG	XLPE	150			0
G5	G6	Ground		10.536057	76.212907	UG	XLPE	150			0
G6	03- Daffodils	Daffodils	LT	10.536280	76.212880	UG	XLPE	150	53.14		53.14
P1	AB-Rukmani1	AB		10.535360	76.212459	OH	Racoon		74.51		74.51
AB-Rukmai1	G10	Ground		10.535359	76.212212	UG	XLPE	300			0
G10	AB-Rukmani2	AB		10.534427	76.212201	UG	XLPE	300	132.19	5	137.19
AB-Rukmani2	26 - Rukmani Temple Park	Rukmani Temple Park	LT	10.534266	76.212454	UG	XLPE	150	32.92	15	47.92
AB-Rukmai1	P5, 4- Karthayani	Post, Karthayani	LT	10.535365	76.212067	OH	Racoon		43.21		43.21
P5	AB, 23- K.R Bakery	K.R Bakery	LT	10.535502	76.212076	OH	Racoon		16.52		16.52
P5	G11	Ground		10.535356	76.211946	UG	XLPE	150			0
G11	G12	Ground		10.535035	76.211949	UG	XLPE	150			0
G12	5-Pazhoor Arcades	Pazhoor Arcades	LT	10.534924	76.212057	UG	XLPE	150	64.81		64.81
P5	ABL51503	AB		10.535290	76.211750	OH	Racoon		34.81		34.81
ABL51503	P6-1	Post		10.535363	76.211656	OH	Racoon				0
P6-1	P6	Post		10.535337	76.211394	OH	Racoon		47.69		47.69
P6	P7	Post		10.535305	76.211192	OH	Racoon				0
P7	P8	Post		10.535304	76.210928	OH	Racoon		46.8		46.8
P8	G13	Ground		10.535326	76.210625	UG	XLPE				0
G13	21-Saraswathy	Saraswathy	LT	10.535447	76.210615	UG	XLPE	300	49.95		49.95

From Map no	Map no	Pole/transformer/ AB	Metering point	Latitude	Longitude	Cable	Cable type	Cable size (sq mm)	Mapping distance (m)	Loose distance (m)	Total distance (m)
P8	P9	Post		10.535319	76.209827	OH	Racoon			125.36	125.36
P9	22 -Unique Ardent	Unique Ardent	LT	10.535463	76.209744	UG	XLPE	150	23.24	5	28.24
P9	ABI50903	AB		10.535324	76.209518	OH	Racoon		28.53		28.53
P6	AB-Panikath, RMU31504	AB, RMU		10.535694	76.211515	OH	Racoon		44.75		44.75
RMU31504	49-Panikath Mall	Panikath Mall	LT	10.535755	76.211320	UG	XLPE	185	22.38	25	47.38
AB-Panikath	P39	Post		10.536430	76.211975	OH	Racoon				0
P39	P40	Post		10.536711	76.212055	OH	Racoon				0
P40	P41, 18-Varnam	Post/Varnam	LT	10.537105	76.212019	OH	Racoon		171.77		171.77
P41	P42	Post		10.537232	76.212017	OH	Racoon		14.05		14.05
P42	19-Omega Panthlon	Omega Panthlon	LT	10.537190	76.211716	UG	XLPE	185	33.27	10	43.27
P42	P43	Post		10.537421	76.212006	OH	Racoon		20.94		20.94
P43	RMU31505	RMU		10.537422	76.211972	UG	XLPE	300	3.72		3.72
RMU31505	43-Prasad Arcade	Prasad Arcade	LT	10.537428	76.211929	UG	XLPE	300	4.76	25	29.76
RMU31505	RMU31506	RMU		10.537224	76.212110	UG	XLPE	300			0
RMU31506	48-CKM Heights	CKM Heights	LT	10.537127	76.212224	UG	XLPE	300	55.06	30	85.06
P43	P45	Post		10.538000	76.212016	OH	Racoon		64.05		64.05
P45	G46	Ground		10.538033	76.211330	UG	XLPE	300			0
G46	G47	Ground		10.538166	76.211151	UG	XLPE	300			0
G47	G48	Ground		10.538509	76.211107	UG	XLPE	300			0
G48	G49	Ground		10.538548	76.210785	UG	XLPE	300			0
G49	G50	Ground		10.539008	76.210873	UG	XLPE	300			0
G50	20-Nandhanam	Nandhanam	LT	10.539011	76.210180	UG	XLPE	300	301.95	10	311.95
ABL51503	P10	Post		10.535146	76.211513	UG	XLPE	300			0
P10	G14	Ground		10.534919	76.211464	UG	XLPE	300			0

From Map no	Map no	Pole/transformer/ AB	Metering point	Latitude	Longitude	Cable	Cable type	Cable size (sq mm)	Mapping distance (m)	Loose distance (m)	Total distance (m)
G14	G15	Ground		10.534555	76.211461	UG	XLPE	300			0
G15	P11	Post		10.534539	76.211384	UG	XLPE	300	106.31	80	186.31
P11	P38	Post		10.534848	76.211409	OH	Racoon				0
P38	6-Kasturi	Kasturi (Bhramasam Madam)	LT	10.534838	76.211515	OH	Racoon		45.94		45.94
P11	G16	Ground		10.534562	76.211042	UG	XLPE				0
G16	G17	Ground		10.534500	76.210738	UG	XLPE				0
G17	7-Sreepriya	Sreepriya	LT	10.534474	76.210642	UG	XLPE	300	82.63	27	109.63
P11	P12	Post		10.534044	76.211321	OH	Racoon		55.07		55.07
P12	RMU31507	RMU		10.534086	76.211424	UG	XLPE	300	11.25	10	21.25
RMU31507	42-Thrissur Service Coperative Bank	Thrissur Service Coperative Bank	HT	10.534001	76.211658	UG	XLPE	185	27.28	5	32.28
P12	P13	Post		10.533857	76.211321	OH	Racoon		21.86		21.86
P13	AB-Krishna	AB		10.533834	76.211275	OH	Racoon		3.74		3.74
AB-Krishna	51-Capital Krishna	Capital Krishna	LT	10.533834	76.211030	UG	XLPE	150	26.82	7	33.82
P13	P14	Post		10.533494	76.211287	OH	Racoon		39.19		39.19
P14	P15	Post		10.533371	76.211138	OH	Racoon				0
P15	P16	Post		10.533361	76.210934	OH	Racoon		44.78		44.78
P16	9-Forus Mathura	Forus Mathura	LT	10.533326	76.210930	OH	Racoon		2.78		2.78
P16	G18	Ground		10.533345	76.210194	UG	XLPE				0
G18	G19	Ground		10.533335	76.209948	UG	XLPE				0
G19	AB-MRG	AB-MRG Sree Valstam		10.533346	76.209556	UG	XLPE	300	151.01	17	168.01
AB-MRG	40 - MRG Sree Valstam	MRG Sree Valstam	LT	10.533188	76.209505	UG	XLPE	150	18.35	7	25.35
P14	P17	Post		10.533027	76.211313	OH	Racoon		51.73		51.73
P17	AB-AR	AB-AR Tower		10.533183	76.211270	OH	Racoon		17.89		17.89
AB-AR	27-A.R. Tower	A R Tower	LT	10.533111	76.211209	UG	XLPE	150	10.39	10	20.39
P17	P18	Post		10.532747	76.211321	OH	Racoon		30.98		30.98

From Map no	Map no	Pole/transformer/ AB	Metering point	Latitude	Longitude	Cable	Cable type	Cable size (sq mm)	Mapping distance (m)	Loose distance (m)	Total distance (m)
P18	8-Krishna(Thiruvambadi-2)	Krishna(Thiruvambadi-2)	LT	10.532713	76.211394	OH	Racoon		8.83		8.83
P18	P19	Post		10.532410	76.211320	OH	Racoon		37.28		37.28
P19	28-Friends Mall	Friends Mall	LT	10.532439	76.211428	OH	Racoon		12.25		12.25
P19	ABL51504	AB		10.532204	76.211308	OH	Racoon		22.82		22.82
ABL51504	RMU31508	RMU		10.531837	76.211354	UG	XLPE	300			0
RMU31508	47-Oushadhi Panchakarma	Oushadhi Panchakarma	HT	10.531810	76.211423	UG	XLPE	300	60.62	20	80.62
ABL51504	P20	Post		10.531825	76.211261	OH	Racoon				0
P20	P21	Post		10.531502	76.211285	OH	Racoon		78.06		78.06
P21	P22	Post		10.531118	76.211380	OH	Racoon		44.69		44.69
P22	P23, 11-Oushadhi	Oushadhi	LT	10.531137	76.211653	OH	Racoon		31.54		31.54
P23	RMU31509	RMU		10.531134	76.211604	UG	XLPE	300	5.37	12	17.37
RMU31509	G20	Ground		10.531110	76.211372	UG	XLPE	300			0
G20	G21	Ground		10.531420	76.211300	UG	XLPE				0
G21	G22	Ground		10.531624	76.211243	UG	XLPE				0
G22	41-Top Tower	Top Tower	LT	10.531572	76.210898	UG	XLPE	300	125.97	20	145.97
RMU31509	G29	Ground		10.531147	76.213005	UG	XLPE	300			0
G29	G30	Ground		10.531152	76.214519	UG	XLPE	300			0
G30	RMU31510	RMU		10.531392	76.214558	UG	XLPE	300			0
RMU31510	44-Kalyan Hypermarket	Kalyan Hypermarket	HT	10.531569	76.214622	UG	XLPE	300	372.87	30	402.87
P23	G20	Ground		10.531110	76.211372	UG	XLPE	300			0
G20	G21	Ground		10.531420	76.211300	UG	XLPE				0
G21	G23	Ground		10.531849	76.211248	UG	XLPE				0
G23	G24	Ground		10.532051	76.210712	UG	XLPE				0

From Map no	Map no	Pole/transformer/ AB	Metering point	Latitude	Longitude	Cable	Cable type	Cable size (sq mm)	Mapping distance (m)	Loose distance (m)	Total distance (m)
G24	G25	Ground		10.532151	76.210608	UG	XLPE				0
G25	G26	Ground		10.532276	76.210085	UG	XLPE				0
G26	G27	Ground		10.532309	76.210146	UG	XLPE				0
G27	P24	Post		10.533034	76.210120	UG	XLPE	300	331.79	10	341.79
P24	10	Thiruvambadi(Lekshmi)	LT	10.533034	76.210133	OH	Racoon		1.42		1.42
P24	G28	Ground		10.532486	76.210111	UG	XLPE	300			0
G28	24-Narayani	Narayani	LT	10.532437	76.210025	UG	XLPE	300	74.28	27	101.28
P22	P25	Post		10.530537	76.211480	OH	Racoon		63.17		63.17
P25	34- K.A Kumaran	K.A Kumaran	LT	10.530561	76.211584	OH	Racoon		9.55		9.55
P25	P26	Post		10.529469	76.211775	OH	Racoon				0
P26	P27	Post		10.529221	76.211838	OH	Racoon		151.68		151.68
P27	G31	Ground		10.529309	76.211808	UG	XLPE	300			0
G31	AB-Saroja	AB		10.529252	76.211497	UG	XLPE				0
AB-Saroja	25- Saroja	Saroja	HT	10.529209	76.211353	UG	XLPE	300	59.31	30	89.31
P27	P28	Post		10.528352	76.212106	OH	Racoon				0
P28	P29	Post		10.527754	76.212235	OH	Racoon				0
P29	ABL51505	AB		10.527750	76.212203	OH	Racoon		171.71		171.71
ABL51505	P30	Post		10.527691	76.211899	UG	XLPE	300	33.91	12	45.91
P30	12-Suharsha	Suharsha	LT	10.527802	76.211990	UG	XLPE	150	15.81	10	25.81
P30	G32	Ground		10.527776	76.211485	UG	XLPE	300			0
G32	RMU31511	RMU		10.527492	76.211395	UG	XLPE	300	72.82	15	87.82
RMU31511	50-Coperative Hospital	Coperative Hospital	HT	10.527558	76.211451	UG	XLPE	300	9.53	30	39.53
RMU31511	AB-Coperative	AB		10.527447	76.211388	UG	XLPE	300	5.04	10	15.04
AB-Coperative	13	Coperative Hospital	LT	10.527462	76.211391	OH	Racoon		1.69		1.69

From Map no	Map no	Pole/transformer/ AB	Metering point	Latitude	Longitude	Cable	Cable type	Cable size (sq mm)	Mapping distance (m)	Loose distance (m)	Total distance (m)
AB-Coperative	G33	Ground		10.527325	76.211332	UG	XLPE	300			0
G33	P31	Post		10.526755	76.211249	UG	XLPE	300	81.82	20	101.82
P31	P32	Post		10.526681	76.211499	OH	Racoon		27.81		27.81
P32	AB-Athulya	AB		10.526493	76.211527	UG	XLPE	300			0
AB-Athulya	16-Athulya Chundari	Athulya Chundari	LT	10.526437	76.211437	UG	XLPE	300	32.82		32.82
P32	P33	Post		10.526654	76.211652	OH	Racoon		17.01		17.01
P33	G34	Ground		10.526620	76.211739	UG	XLPE	300			0
G34	G35	Ground		10.526438	76.211747	UG	XLPE	300			0
G35	G36	Ground		10.526376	76.211712	UG	XLPE	300			0
G36	G37	Ground		10.526357	76.211587	UG	XLPE	300			0
G37	G38	Ground		10.525998	76.211592	UG	XLPE	300			0
G38	G39	Ground		10.525996	76.211637	UG	XLPE	300			0
G39	LBS	LBS		10.525804	76.211084	UG	XLPE	300	166.19		166.19
LBS	14-City Centre 1	City Centre 1	LT	10.525785	76.211087	UG	XLPE	150	2.68		2.68
LBS	15-City Centre 2	City Centre 2	LT	10.525840	76.211080	UG	XLPE	150	4.42	8	12.42
P31	ABL51506	AB		10.526780	76.210751	OH	Racoon		54.84		54.84
ABL51506	G40	Ground		10.527703	76.210718	UG	XLPE	300			0
G40	G41	Ground		10.528060	76.210860	UG	XLPE				0
G41	39-Alukkas Nest	Alukkas Nest	LT	10.527986	76.210965	UG	XLPE	300	159.31		159.31
ABL51506	33-Malabar Eye Clinic	Malabar Eye Clinic	LT	10.526870	76.210444	OH	Racoon		35.05		35.05
ABL51506	G42	Ground		10.526747	76.210648	UG	XLPE	300			0
G42	G43	Ground		10.526233	76.210630	UG	XLPE				0
G43	G44	Ground		10.525134	76.210667	UG	XLPE	300			0
G44	AB-Shivam	AB		10.525158	76.210847	UG	XLPE	300	207.78	10	217.78
AB-Shivam	17-Shivam	Shivam		10.525080	76.210919	UG	XLPE	300	11.69	30	41.69

From Map no	Map no	Pole/transformer/ AB	Metering point	Latitude	Longitude	Cable	Cable type	Cable size (sq mm)	Mapping distance (m)	Loose distance (m)	Total distance (m)
AB-Shivam	P34	Post		10.525152	76.210670	UG	XLPE	300	19.39	10	29.39
P34	P35	Post		10.524674	76.210693	OH	Racoon		52.93		52.93
P35	29-Ramdas Theatre	Ramdas Theatre	HT	10.524432	76.210736	UG	XLPE	300	30.92	5	35.92
P35	AB-Peninsula	AB		10.524647	76.210686	OH	Racoon		3.08		3.08
AB-Peninsula	30-Peninsula	Peninsula	HT	10.524161	76.210655	UG	XLPE	150	53.86	75	128.86
P35	G45	Ground		10.524632	76.210242	UG	XLPE	300			0
G45	ABI50808	AB		10.523928	76.210241	UG	XLPE	300	130.61	7	137.61
P34	P36	Post		10.525399	76.210645	OH	Racoon		27.46		27.46
P36	P36-1	AB		10.525436	76.210713	OH	Racoon		8.49		8.49
P36-1	31-Wintage Royal	Wintage Royal	LT	10.525355	76.210795	UG	XLPE	185	12.68	50	62.68
P36	P37	Post		10.525881	76.210646	OH	Racoon		53.31		53.31
P37	37-Top Heritage	Top Heritage	LT	10.525845	76.210826	UG	XLPE	150	20.1	20	40.1
P37	P37-1	AB		10.525819	76.210579	OH	Racoon		10.04		10.04
P37-1	38-Forus Cosynest	Forus Cosynest	LT	10.525893	76.210456	UG	XLPE	150	15.76	20	35.76

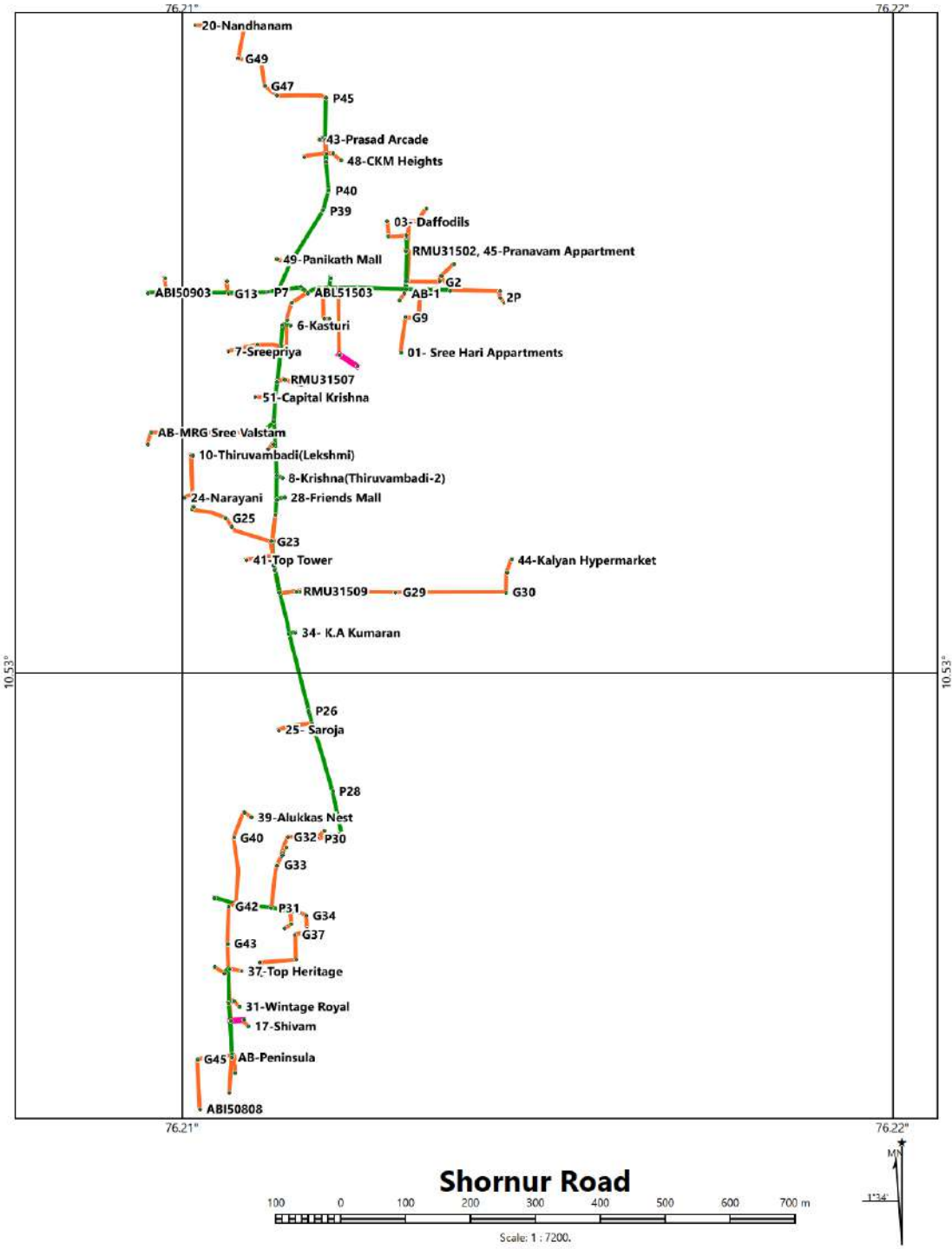

Figure 8: Shornur road feeder

8 VELIYANOOR

The following table shows the 11-kV line distance in the Veliyanoor feeder

Table 22: HT line distance – Veliyanoor feeder

From Map no	Map no	Pole/transformer/ AB	Metering point	Latitude	Longitude	Cable	Cable type	Cable size (sq mm)	Mapping distance (m)	Loose distance (m)	Total distance (m)
	S-S	Substation feeder		10.517355	76.219663						
S-S	P1	Post		10.517120	76.219563	UG	XLPE	300	28.2	32	60.2
P1	P2	Post		10.517085	76.219594	OH	Racoon		7.68		7.68
P2	1	Assay Hall Marking	LT	10.517240	76.219773	OH	Racoon		26.7		26.7
P1	P3, 21	Airtel Tower	LT	10.517268	76.219442	OH	Racoon		19.76		19.76
P3	P24	AB Manorama		10.517096	76.219261	OH	Racoon		21.27		21.27
P24	2	Manorama	HT	10.516767	76.219534	UG	XLPE	300	48	7	55
P2	G14-1	Ground		10.517000	76.219530	UG	XLPE	300			0
G14-1	G14-2			10.517180	76.219360	UG	XLPE	300			0
G14-2	G14			10.516906	76.218968	UG	XLPE	300			0
G14	22	Chicago	LT	10.516700	76.218968	UG	XLPE	300	117.95	10	127.95
P24	P25	Post		10.516706	76.218659	OH	Racoon		78.25		78.25
P25	3	C J Tower	LT	10.516875	76.218557	OH	Racoon		24.38		24.38
P25	P26	Post		10.516106	76.217811	OH	Racoon		114.59		114.59
P26	P27	Post		10.516010	76.217036	UG	XLPE	300	326.13	10	336.13
P27	RMU30201	RMU		10.515988	76.217010	UG	XLPE	300	5.67	9	14.67
P27	AB Sakthan Market, 4	Sakthan Market	LT	10.515958	76.216764	OH	Racoon		30.32		30.32
AB Sakthan Market	RMU30206	RMU		10.515919	76.216744	UG	XLPE	300	4.84		4.84
RMU30206	26	Edu Mart	HT	10.515732	76.216878	UG	XLPE	240	25.36	7	32.36
P27	P28	Post		10.516006	76.217500	OH	Racoon				
P28	ABL50203	AB		10.516365	76.217354	OH	Racoon				

From Map no	Map no	Pole/transformer/ AB	Metering point	Latitude	Longitude	Cable	Cable type	Cable size (sq mm)	Mapping distance (m)	Loose distance (m)	Total distance (m)
ABL50203	P29	Post		10.517367	76.217196	OH	Racoon				
P29	P30	Post		10.517411	76.217316	OH	Racoon				
P30	P31	Post		10.517614	76.217937	OH	Racoon				
P31	P31-1	Post		10.518050	76.217844	OH	Racoon		25		25
RMU30201	G15	Ground		10.516405	76.217503	UG	XLPE	300			
G15	G16	Ground		10.517390	76.217294	UG	XLPE	300			
G16	G17	Ground		10.517614	76.217937	UG	XLPE	300			
G17	G18	Ground		10.518070	76.217907	UG	XLPE	300			
G18	RMU30202	RMU		10.518060	76.217850	UG	XLPE	300			
RMU30202	14	Latin Palli		10.518050	76.217844	UG	XLPE	300	323.63		323.63
RMU30202	G19	Ground		10.518082	76.217924	UG	XLPE	300			0
G19	G20	Ground		10.518431	76.218937	UG	XLPE	300			0
G20	RMU30203, 24	Vivid Press	LT	10.517753	76.219192	UG	XLPE	300	209.44	10	219.44
RMU30202	G24	Ground		10.517670	76.217912	UG	XLPE	300			0
G24	G25	Ground		10.517456	76.217245	UG	XLPE	300			0
G25	G26	Ground		10.517981	76.216941	UG	XLPE	300			0
G26	G27	Ground		10.518525	76.216588	UG	XLPE	300			0
G27	G28	Ground		10.519618	76.216723	UG	XLPE	300			0
G28	RMU30204	RMU		10.520465	76.216858	UG	XLPE	300	488.48		488.48
RMU30204	G31	Ground		10.520568	76.216720	UG	XLPE	300			0
G31	G32	Ground		10.520477	76.216184	UG	XLPE	300			0
G32	RMU30205, 25	Sakunthala	HT	10.520222	76.215997	UG	XLPE	300	141.99		141.99
RMU30204	G29	Ground		10.520481	76.216802	UG	XLPE	300			0
G29	G30	Ground		10.521385	76.216822	UG	XLPE	300			0
G30	RMU31606	RMU		10.522609	76.216895	UG	XLPE	300	245.44		245.44
AB Sakthan	P4	Post		10.515999	76.216432	OH	Racoon		36.62		36.62

From Map no	Map no	Pole/transformer/ AB	Metering point	Latitude	Longitude	Cable	Cable type	Cable size (sq mm)	Mapping distance (m)	Loose distance (m)	Total distance (m)
P4	G1	Ground		10.515939	76.215913	UG	XLPE	300			0
G1	RMU30207	RMU		10.515870	76.215930	UG	XLPE	300			0
RMU30207	G2	Ground		10.515853	76.215567	UG	XLPE	300			0
G2	G3	Ground		10.516028	76.215361	UG	XLPE	300			0
G3	AB OWC	AB		10.516210	76.214917	UG	XLPE	300	186.3		186.3
AB OWC	20	OWC Plant	LT	10.516223	76.214920	OH	Racoon		4.02		4.02
AB OWC	AB Police	AB		10.516574	76.214587	UG	XLPE	300	53.71		53.71
AB Police	G21	Ground		10.516240	76.215451	UG	XLPE	300			0
G21	G22	Ground		10.516392	76.215671	UG	XLPE	300			0
G22	G23	Ground		10.518324	76.215873	UG	XLPE	300			0
G23	RMU30208	RMU		10.518371	76.215651	UG	XLPE	300			0
RMU30208	27	Office of commissioner of Police	HT	10.518777	76.215659	UG	XLPE	300	416.45	50	466.45
AB Police	P5	Post		10.517182	76.213144	OH	Racoon				0
P5	P6	Post		10.517245	76.212674	OH	Racoon				0
P6	ABL50204, 05	Ramanchira madom	LT	10.517227	76.212519	OH	Racoon		240.67		240.67
ABL50204	G2-1	Ground		10.517629	76.212579	UG	XLPE	300			0
G2-1	G3-1	Ground		10.517600	76.212537	UG	XLPE	300			0
G3-1	G4	Ground		10.518388	76.212586	UG	XLPE	300			0
G4	RMU31211	RMU		10.518355	76.212265	UG	XLPE	300	169.98		169.98
ABL50204	G5	Ground		10.517096	76.212591	UG	XLPE	300			
G5	P7	Post		10.516916	76.212593	UG	XLPE	300			
P7	P8	Post		10.516703	76.212606	UG	XLPE	300	60.01	40	100.01
P8	13	Hari Sree Apartment	LT	10.516706	76.212583	OH	Racoon			2.54	2.54
P8	G7	Ground		10.515926	76.212675	UG	XLPE	300			0
G7	G8	Ground		10.515914	76.213156	UG	XLPE	300			0
G8	G9	Ground		10.515340	76.213290	UG	XLPE	300			0

From Map no	Map no	Pole/transformer/ AB	Metering point	Latitude	Longitude	Cable	Cable type	Cable size (sq mm)	Mapping distance (m)	Loose distance (m)	Total distance (m)
G9	G10	Ground		10.514978	76.213209	UG	XLPE	300			0
G10	ABL50207, 7	Rashtra Deepika	LT	10.515052	76.212532	UG	XLPE	300	321.88		321.88
ABL50207	RMU30209	RMU		10.515076	76.212603	UG	XLPE	300	8.21		8.21
RMU30209	16	Rastra Deepika Press	HT	10.515136	76.212605	UG	XLPE	185	6.64		6.64
ABL50207	P19	Post		10.515046	76.212713	OH	Racoon				0
P19	AB Joys palace	AB		10.514975	76.212697	OH	Racoon		27.87		27.87
AB Joys palace	8	Joy palace	HT	10.514889	76.212808	UG	XLPE	185	15.43	15	30.43
ABL50207	P20	Post		10.515069	76.212060	OH	Racoon		51.7		51.7
P20	9	MRG Flat	LT	10.514961	76.212087	OH	Racoon		12.31		12.31
P20	P21	Post		10.515140	76.211393	OH	Racoon		73.1		73.1
P21	G11	Ground		10.515177	76.211227	UG	XLPE	300			
G11	G12	Ground		10.515603	76.211381	UG	XLPE	300			
G12	RMU30210	RMU		10.515593	76.211409	UG	XLPE	300			
RMU30210	23	New Jwala Diamond Jewellery	HT	10.515598	76.211671	UG	XLPE	300	101.3	45	146.3
P21	P22	Post		10.515052	76.211590	OH	Racoon				0
P22	P23	Post		10.514674	76.210980	OH	Racoon		73.35		73.35
P23	AB Inland	AB		10.514677	76.210917	OH	Racoon		6.9		6.9
AB Inland	G13	Ground		10.514686	76.210722	UG	XLPE	185			0
G13	10	inland	LT	10.514755	76.210960	UG	XLPE	185	34.44	6	40.44
P23	ABI50208	AB		10.513886	76.210747	OH	Racoon		90.82		90.82
ABL50204	P9	Post		10.517186	76.212176	OH	Racoon				0
P9	P10	Post		10.517253	76.211889	OH	Racoon				0
P10	P11	Post		10.517364	76.211622	OH	Racoon		104.99		104.99
P11	P12	Post		10.517145	76.211564	OH	Racoon		23.55		23.55
P12	P13	Post		10.517039	76.211527	OH	Racoon				0

From Map no	Map no	Pole/transformer/ AB	Metering point	Latitude	Longitude	Cable	Cable type	Cable size (sq mm)	Mapping distance (m)	Loose distance (m)	Total distance (m)
P13	AB PPY	AB PP Yohanan		10.517024	76.211514	OH	Racoon		15.32		15.32
AB PPY	15	P P Yohanan				UG	XLPE	240	Not Connected		
P12	ABL50206	AB		10.517170	76.211392	UG	XLPE	300	16.4		16.4
ABL50206	AB Jwala 1	AB		10.517155	76.211030	OH	Racoon		39.93		39.93
AB Jwala 1	G6	Ground		10.516730	76.210961	UG	XLPE	300			0
G6	AB Jwala 2, 11	Jwala Diamond	LT	10.516670	76.211082	UG	XLPE	300	65.9	12	77.9
AB Jwala 1	P14	Post		10.517166	76.210722	OH	Racoon				0
P14	P15	Post		10.517160	76.210540	OH	Racoon				0
P15	P16	Post		10.517056	76.209794	OH	Racoon		134.8		134.8
P16	AB Malabar Tower	AB		10.517035	76.209804	OH	Racoon		4.09		4.09
AB Malabar Tower	12	Malabar Tower	LT	10.516946	76.209910	UG	XLPE	185	10.32	50	60.32
P16	AB Emerald	AB		10.517213	76.209596	OH	Racoon		30.9		30.9
AB Emerald	18, 19	Emerald 1, Emerald 2	HT, LT	10.517180	76.209539	UG	XLPE	300	7.23	30	37.23
P11	P17	Post		10.517725	76.211781	OH	Racoon		45.34		45.34
P17	AB Mani	AB		10.517658	76.211842	OH	Racoon		11.93		11.93
AB Mani	6	Manichitra Arcades	LT	10.517661	76.212197	UG	XLPE	300	38.86	5	43.86
P17	P17-1	Post		10.517876	76.211815	OH	Racoon				
P17-1	AB EMK	AB		10.518064	76.211849	OH	Racoon		37.56		37.56
AB EMK	17	EMKE Silks	HT	10.517785	76.211397	UG	XLPE	300	69.52	10	79.52
P17	P17-1	Post		10.517876	76.211815	OH	Racoon				
P17-1	P18	Post		10.518412	76.211925	OH	Racoon		77.22		77.22

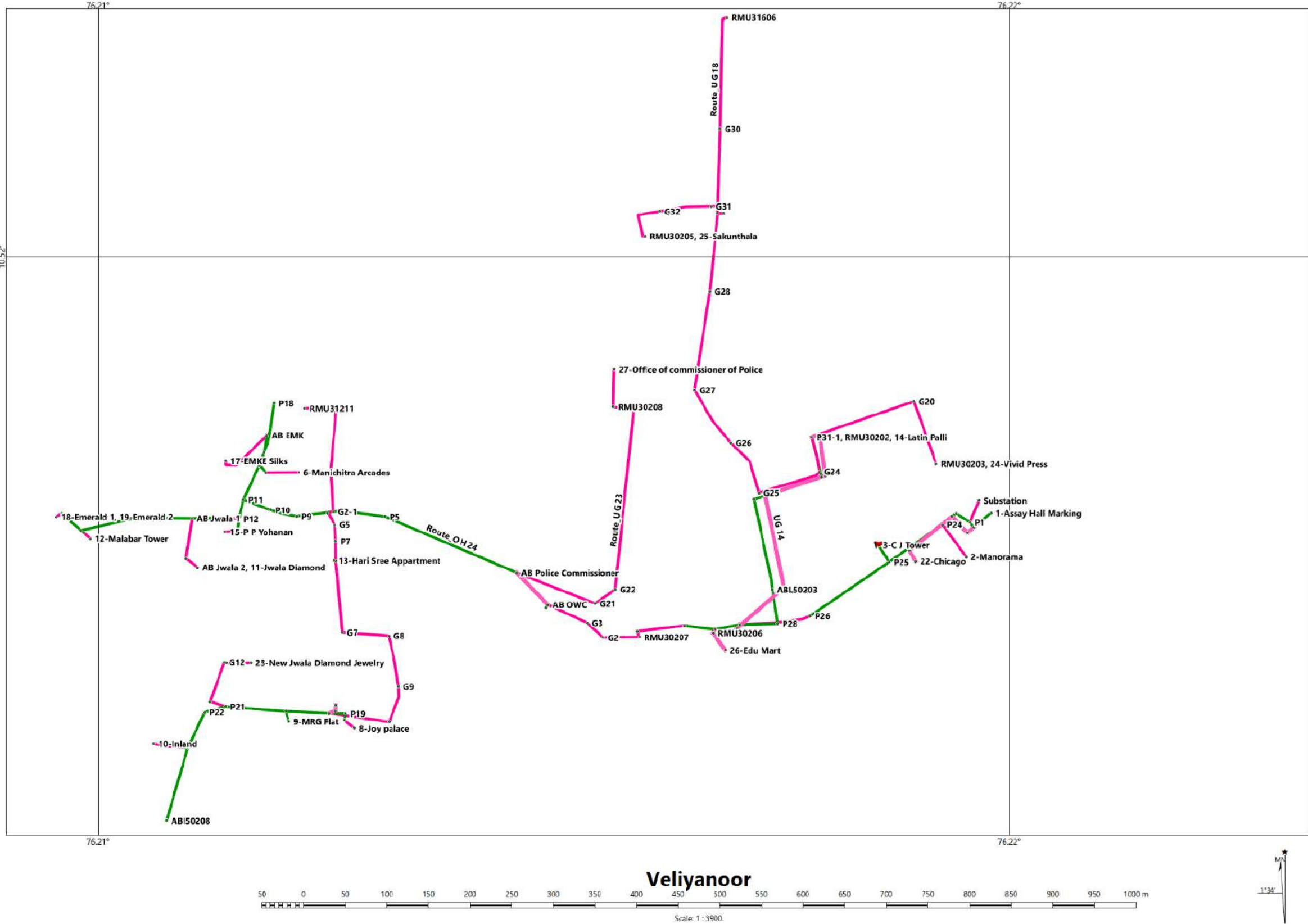

Figure 9: Veliyanoor feeder

9 VIVEKODAYAM FEEDER

The following table shows the 11-kV line distance in the Vivekodayam feeder

Table 23: HT line distance –Vivekodayam feeder

From Map no	Map no	Pole/transformer/AB	Metering point	Latitude	Longitude	Cable	Cable type	Cable size (sq mm)	No of runs	Mapping distance (m)	Loose distance (m)	Total distance (m)
SS		Substation		10.535194	76.214591							
SS	P1	Substation feeder		10.535198	76.214825	UG	XLPE	300	1	25.62	55	80.62
P1	P2	Post		10.535236	76.214901	OH	Racoon			9.32		9.32
P2	P3	Post		10.534813	76.214965	OH	Racoon			47.31		47.31
P3	P4	Post		10.534748	76.215028	OH	Racoon			9.96		9.96
P4	P29	AB aswani		10.534517	76.215031	OH	Racoon			25.55		25.55
P29	31	Aquatic (Sai)	LT	10.534494	76.21496	OH	Racoon			8.18		8.18
P29	G1	Ground		10.534560	76.215007	UG	XLPE	300	1			
G1	G2	Ground		10.534597	76.214725	UG	XLPE					
G2	LBS	Aswini Hospital		10.534563	76.214736	UG	XLPE	300	1	41.36		41.36
LBS	01,02	Aswini Hospital	HT			UG	XLPE	150	2		40	40
P29	P5	Post		10.533255	76.215052	OH	Racoon			134.68		134.68
P5	P30	AB SG Complex		10.531338	76.215073	OH	Racoon			217		217
P30	G3	Ground		10.531405	76.215063	UG	XLPE	240	1			0
G3	15	SG Complex	HT	10.531427	76.214973	UG	XLPE	240		17.52		17.52
P30	P5-1	Post		10.531050	76.215095	OH	Racoon			31.95		31.95
P5	P6	Post		10.533251	76.214487	OH	Racoon			62.6		62.6
P6	P7	Post		10.533346	76.213460	OH	Racoon					0
P7	P7-1	Post		10.533444	76.213114	OH	Racoon					0
P7-1	P31	AB Govind Apartment		10.533484	76.213114	OH	Racoon			156.85		156.85
P31	G4	Ground		10.533604	76.213125	UG	XLPE	240	1			0
G4	3	Govind Apartment	LT	10.533616	76.213024	UG	XLPE	240	1	24.46		24.46

From Map no	Map no	Pole/transformer/AB	Metering point	Latitude	Longitude	Cable	Cable type	Cable size (sq mm)	No of runs	Mapping distance (m)	Loose distance (m)	Total distance (m)
P6	AB1,P32, P32'29	AB Swimming pool, AB silver rox, ABL50702, Swimming Pool TR	LT	10.532844	76.214458	OH	Racoon			49.23		49.23
P32'	G5	Ground		10.532888	76.213808	UG	XLPE	300	1			0
G5	RMU1	RMU30701		10.532755	76.213804	UG	XLPE	300	1	86.03		86.03
RMU1	28	Silver Roxx	LT	10.532661	76.213848	UG	XLPE	240	1	11.46		11.46
P32'	P8	Post		10.532428	76.214427	OH	Racoon			46.14		46.14
P8	P33	AB Kalindi		10.532444	76.214264	OH	Racoon			17.93		17.93
P33	14	Kalindi	LT	10.532383	76.214074	UG	XLPE	300	1	21.86	35	56.86
AB1	G6	Ground		10.532239	76.214421	UG	XLPE	300	1			0
G6	G7	Ground		10.532109	76.214662	UG	XLPE					0
G7	G8	Ground		10.531113	76.214438	UG	XLPE					0
G8	P34	AB Bhima		10.531109	76.214133	UG	XLPE	300	1	243.12		243.12
P34	G19	Ground				UG	XLPE	300				0
G19	4	Bhima	HT	10.530717	76.213987	UG	XLPE	300	1	61.77		61.77
P34	P9	Post		10.531108	76.212977	OH	Racoon			126.53		126.53
P9	P9-1	Post		10.530778	76.212920	OH	Racoon					0
P9-1	P35	AB vanvita		10.530742	76.212816	OH	Racoon			49.09		49.09
P35	5	Vanvita	HT	10.530800	76.212816	UG	XLPE	300	1	6.42	25	31.42
P9	AB2,AB3	ABI50703,ABL50704		10.531138	76.211802	OH	Racoon			128.65		128.65
AB2	G9	Ground		10.531077	76.211470	UG	XLPE	300	1	16.92		16.92
G9	G10	Ground		10.529868	76.211727	UG	XLPE			141.47		141.47
G10	G11	Ground		10.529850	76.211628	UG	XLPE			11.02		11.02
G11	P10	Post		10.529501	76.211025	UG	XLPE	300	1	76.46		76.46
P10	6	Capital Manner	LT	10.529441	76.211055	OH	Racoon			7.4		7.4
P10	P11	Post		10.529294	76.210639	OH	Racoon			49.57		49.57
P11	P12	Post		10.529927	76.210698	OH	Racoon					0

From Map no	Map no	Pole/transformer/AB	Metering point	Latitude	Longitude	Cable	Cable type	Cable size (sq mm)	No of runs	Mapping distance (m)	Loose distance (m)	Total distance (m)
P12	P13	Post		10.530257	76.210091	OH	Racoon					0
P13	P14	Post		10.530857	76.209991	OH	Racoon					0
P14	P14-1	Post		10.530990	76.209990	OH	Racoon					
P14-1	P36	AB1 sreekrishna		10.531005	76.210070	OH	Racoon			234.55		234.55
P36	G12	Ground		10.531012	76.210437	UG	XLPE	300	1			0
G12	G13	Ground		10.530867	76.210518	UG	XLPE					0
G13	P37	AB2 sreekrishna		10.530883	76.210721	UG	XLPE	300	1			0
P37	11	Sree Krishna Apartment	LT	10.530753	76.210736	UG	XLPE	300	1	92.48	16	108.48
P11	P15	Post		10.528695	76.210305	OH	Racoon			72.99		72.99
P15	P38,07	AB-Souparnika, Souparnika	LT	10.528683	76.210264	OH	Racoon			3.57		3.57
P38	G22	Ground		10.52834	76.210220	UG	XLPE					0
G22	G22-1	Ground		10.52809	76.209960	UG	XLPE					0
G22-1	G22-2	Ground		10.527890	76.209830	UG	XLPE					0
G20-2	AB4	ABL50705		10.526901	76.209650	UG	XLPE	300	1	213.31		213.31
AB4	AB5	ABL50706		10.526969	76.209495	OH	Racoon			13.28		13.28
AB5	G12-1	Ground		10.52695	76.20954	UG	XLPE	300	1			0
G12-1	G12	Ground		10.527281	76.209642	UG	XLPE					0
G12	RMU2, 16	RMU30702, Mukundha Apartment	LT	10.527293	76.209615	UG	XLPE	300	1	45.93	2	47.93
AB5	G12-1	Ground		10.52695	76.20954	UG	XLPE					
G12-1	G12	Ground		10.527281	76.209642	UG	XLPE					
G12	G12-2	Ground		10.52764	76.20974	UG	XLPE					
G12-2	P39	AB satyam		10.527662	76.209686	UG	XLPE	300	1	87.27		87.27
P39	8	Satyam	LT	10.527851	76.209558	UG	XLPE	300	1	28.23	20	48.23
P39	LBS(G)	Ground(LBS)		10.527433	76.209679	UG	XLPE	300	1			0
LBS(G)	12	Shivam	LT	10.527509	76.209558	UG	XLPE	300	1	39.37		39.37

From Map no	Map no	Pole/transformer/AB	Metering point	Latitude	Longitude	Cable	Cable type	Cable size (sq mm)	No of runs	Mapping distance (m)	Loose distance (m)	Total distance (m)
AB4	P16	Post		10.526846	76.209493	OH	Racoon					0
P16	P16-1	Post		10.52664	76.20958	OH	Racoon					
P16-1	P17	Post		10.526361	76.209679	OH	Racoon					0
P17	P18	Post		10.525921	76.209726	OH	Racoon			122.07		122.07
P18	P40	AB sreehari		10.525945	76.209758	OH	Racoon			2.65		2.65
P40	9	Sree Hari	LT	10.525937	76.210051	UG	XLPE	240	1	32.08		32.08
P18	P19	Post		10.525819	76.209586	OH	Racoon					0
P19	P20	Post		10.524283	76.209863	OH	Racoon					0
P20	P20-1	Post		10.524239	76.209763	OH	Racoon			202.93		202.93
P20-1	13	Mannath Lane(NP Tower)	LT	10.524206	76.209846	OH	Racoon			6.58		6.58
P20-1	P41	AB-Ambika Arcades		10.523845	76.209846	OH	Racoon			42.71		42.71
P41	24	Ambika Arcades	LT	10.523921	76.209577	UG	XLPE	300	1	30.62	30	60.62
P41	P27	Post		10.523688	76.209783	OH	Racoon			18.6		18.6
P27	P45, 23	AB-Music Park, Music Park	LT	10.523625	76.209808	OH	Racoon			7.09		7.09
P27	P46	AB-Anamya Tower		10.523638	76.209755	OH	Racoon			6.55		6.55
P46	G19-1	Ground		10.52361	76.20962	UG	XLPE					0
G19-1	25	Anamya Tower	LT	10.523412	76.20964	UG	XLPE	300	1	37.27	15	52.27
P27	P28, 26	Post, Karuvan	LT	10.523523	76.209204	OH	Racoon			73.52		73.52
P27	G28-1	Ground		10.52357	76.2092	UG	XLPE					
G28-1	RMU4,30	RMU30703, Brahmasam Madom	LT	10.523343	76.209189	UG	XLPE	300	1	33.52	15	48.52
P28	AB6	ABI50504		10.523420	76.208130	OH	Racoon			110.55		110.55
P27	P21	Post		10.523664	76.209784	OH	Racoon			40.31		40.31
P21	G20	Ground		10.523410	76.210170	UG	XLPE					
G20	P47	AB-Capital Heritage		10.523416	76.210200	UG	XLPE	300	1	38.79		38.79
P47	22	Capital Heritage	LT	10.523399	76.210428	UG	XLPE	300	1	11.61	15	26.61

From Map no	Map no	Pole/transformer/AB	Metering point	Latitude	Longitude	Cable	Cable type	Cable size (sq mm)	No of runs	Mapping distance (m)	Loose distance (m)	Total distance (m)
P47	G20	Ground		10.523410	76.210170	UG	XLPE					
G20	G20-1	Ground		10.523190	76.2102	UG	XLPE					
G20-1	P48, AB7	AB-Temple Tree, ABL50707		10.523157	76.210224	UG	XLPE	300	1	31.55		31.55
P48	G21	Ground		10.52321	76.21048	UG	XLPE					
G21	21	Temple Tree	LT	10.522941	76.210513	UG	XLPE	300	1	57.72	30	87.72
AB7	AB8,P49	ABL50708, AB-Karthiyini1		10.523022	76.210176	OH	Racoon			15.83		15.83
P49	G14	Ground		10.522815	76.210240	UG	XLPE	300	1			0
G14	P50	AB-Karthiyini 2		10.522852	76.210672	UG	XLPE	300	1			0
P50	19	Karthiyini	LT	10.522676	76.210571	UG	XLPE	185	1	93.8	30	123.8
AB7	G15	Ground		10.522792	76.210359	UG	XLPE	300	1			0
G14	P51	AB-Leo Enterprises		10.523217	76.211669	UG	XLPE	300	1	200.51		200.51
P51	20	Leo Enterprises	HT	10.523058	76.211697	UG	XLPE	300	1	18.45	32	50.45
P51	P52	AB-Hall Mark		10.523250	76.211843	OH	ABC			18.02		18.02
P52	18	Cochin Hall Mark	HT	10.523162	76.211928	UG	XLPE	300	1	16.26	5	21.26
AB8	G14	Ground		10.522805	76.210311	UG	XLPE					
G14	G15	Ground		10.522792	76.210359	UG	XLPE					
G15	G16	Ground		10.522205	76.210385	UG	XLPE					
G16	G16-1	Ground		10.521597	76.210125	UG	XLPE					
G16-1	G16-2			10.52175	76.21023	UG	XLPE					
G16-2	G17			10.52158	76.21012	UG	XLPE					
G17	G18	Ground		10.521044	76.210204	UG	XLPE					
G18	G18-1			10.52115	76.21065	UG	XLPE					
G18-1	RMU5, 17	RMU30704,Thiruvambadi Devasm	HT	10.521188	76.211064	UG	XLPE	300	1	337.27		337.27
RMU5	27	Vrindavan Hotel	HT	10.521279	76.211033	UG	XLPE	300	1	10.62	40	50.62

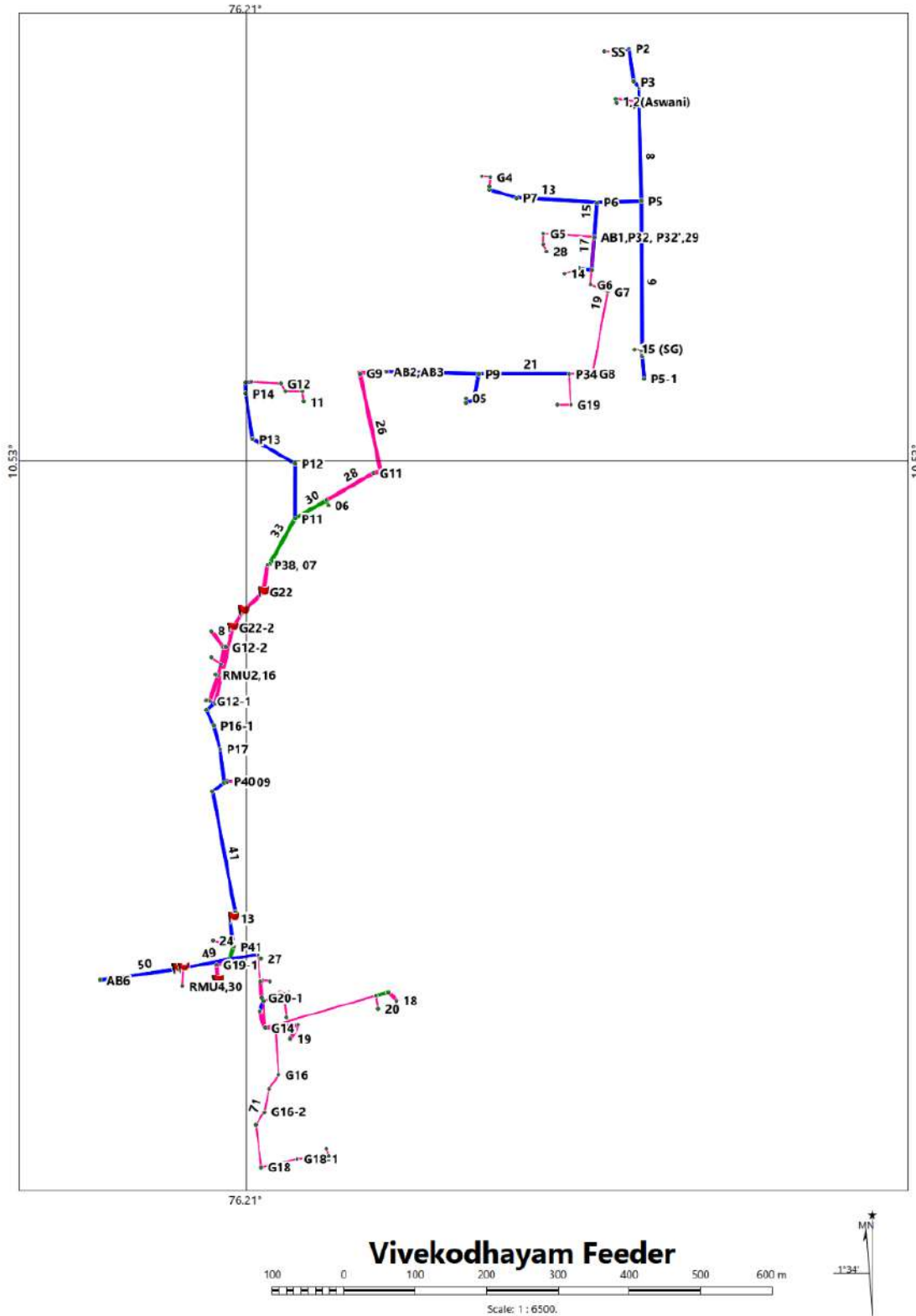

10 DISTRICT HOSPITAL FEEDER

The following table shows the 11-kV line distance in the District Hospital feeder

Table 24: HT line distance –District Hospital feeder

From Map no	Map no	Pole/transformer/AB	Metering point	Latitude	Longitude	Cable	Cable type	Cable size (sq mm)	No of runs	Mapping distance (m)	Loose distance (m)	Total distance (m)
ss		Substation		10.535032	76.21468							
ss	P1	Post		10.535169	76.21482	UG	XLPE	300	1		32	32
P1	G1	Ground		10.535167	76.214897	UG	XLPE	300	1			0
G1	G2	Ground		10.534993	76.215005	UG	XLPE	300	1			0
G2	P2	Post		10.533756	76.215037	UG	XLPE	300	1			0
P2	G3	Ground		10.533433	76.21523	UG	XLPE	300	1			0
G3	G4	Ground		10.533434	76.215886	UG	XLPE	300	1			0
G4	G5	Ground		10.533072	76.216439	UG	XLPE	300	1			0
G5	P3	Post		10.532964	76.216742	UG	XLPE	300	1		20	20
P3	G6	Ground		10.53297	76.217114	UG	XLPE	300	1			0
G6	G7	Ground		10.530994	76.217077	UG	XLPE	300	1			0
G7	G8	Ground		10.530878	76.21771	UG	XLPE	300	1			0
G8	G9	Ground		10.530907	76.217979	UG	XLPE	300	1			0
G9	G10	Ground		10.5308143	76.218087	UG	XLPE	300	1			0
G10	P4	Post		10.530785	76.218877	UG	XLPE	300	1		20	20
P4	G11	Ground		10.530781	76.219309	UG	XLPE	300	1			0
G11	ABL51602	ABL		10.529775	76.219311	UG	XLPE	300	1	1047.65	30	1077.7
ABL51602	37	Kerala Water Authority	LT	10.529766	76.21927	UG	XLPE	300	1	5.28	10	15.28
ABL51602	P5	Post		10.529734	76.219399	OH	Racoon			7.77		7.77
P5	ABI51403	ABI		10.529898	76.219402	OH	Racoon			18.14		18.14
P5	P6	Post		10.529543	76.219389	OH	Racoon					0

From Map no	Map no	Pole/transformer/AB	Metering point	Latitude	Longitude	Cable	Cable type	Cable size (sq mm)	No of runs	Mapping distance (m)	Loose distance (m)	Total distance (m)
P6	P7	Post		10.52894	76.219413	OH	Racoon			87.91		87.91
P7	AB Vyapari	AB		10.528954	76.219332	OH	Racoon			9		9
AB Vyapari	RMU31601	RMU		10.528751	76.219349	UG	XLPE	300	1	22.53	7	29.53
RMU31601	36	Vyapari Vyavasai	LT	10.528773	76.219132	UG	XLPE	150	1	23.88	9	32.88
AB Vyapari	G12	Ground		10.52893	76.218989	UG	XLPE	300	1			0
G12	31-Good Will	Good Will	HT	10.528682	76.218984	UG	XLPE	300	1	66.33	5	71.33
P7	P8	Post		10.528216	76.219522	OH	Racoon			80.97		80.97
P8	P9	Post		10.528208	76.220178	OH	Racoon					0
P9	AB Cheloor	AB		10.528206	76.220254	OH	Racoon			80.27		80.27
AB Cheloor	1	Cheloor Golden Enclave	LT	10.527912	76.220332	UG	XLPE	150	1	34.71	36	70.71
AB Cheloor	AB Fortune, 42-Classic Fortune	Classic Fortune	LT	10.528243	76.220823	OH	Racoon			62.21		62.21
AB Cheloor	AB Forus	AB		10.528220	76.220244	OH	Racoon			16.07		16.07
AB Forus	RMU Azalia	RMU		10.528220	76.220244	UG	XLPE	300			20	20
RMU Azalia	Forus Azalia	Forus Azalia(NEW T /F)	LT	10.528096	76.220131	UG	XLPE	300		18.47	15	33.47
AB Fortune	G13	Ground		10.528235	76.221326	UG	XLPE	300	1			0
G13	G14	Ground		10.529097	76.221347	UG	XLPE	300	1			0
G14	G15	Ground		10.529258	76.221347	UG	XLPE	300	1			0
G15	5-Exchange	Exchange (Chembukavu Feeder)		10.529155	76.221823	UG	XLPE	300	1	212.25	5	217.25
P8	P9-1	Post		10.527585	76.219584	OH	Racoon					0

From Map no	Map no	Pole/transformer/AB	Metering point	Latitude	Longitude	Cable	Cable type	Cable size (sq mm)	No of runs	Mapping distance (m)	Loose distance (m)	Total distance (m)
P9-1	AB Menachery	AB		10.527106	76.219684	OH	Racoon			124.23		124.23
AB Menachery	G16	Ground		10.527007	76.219705	UG	XLPE	300	1			0
G16	3-Menachery	Menachery	LT	10.527015	76.219974	UG	XLPE	300	1	40.65	10	50.65
AB Menachery	P10	Post		10.52655	76.219774	OH	Racoon			62.28		62.28
P10	P11	Post		10.526486	76.219836	OH	Racoon					0
P11	P12	Post		10.526488	76.220605	OH	Racoon			93.98		93.98
P12	AB Cheloor	AB		10.526434	76.2206	OH	Racoon			6		6
AB Cheloor	4	Cheloor Platinum Heights	LT	10.526155	76.220659	UG	XLPE	300	1	31.53	10	41.53
P12	G17	Ground		10.526523	76.220969	UG	XLPE	300	1			0
G17	G18	Ground		10.526588	76.221401	UG	XLPE	300	1			0
G18	G19	Ground		10.526474	76.22142	UG	XLPE	300	1			0
G19	G20	Ground		10.526153	76.221338	UG	XLPE	300	1			0
G20	G21	Ground		10.525393	76.221108	UG	XLPE	300	1			0
G21	G22	Ground		10.525372	76.220707	UG	XLPE	300	1			0
G22	RMU31602	RMU		10.525277	76.220728	UG	XLPE	300	1	279.23		279.23
RMU31602	41-Alfa Breeza	Alfa Breeza	LT	10.525274	76.220582	UG	XLPE	150	1	15.98	15	30.98
P10	P13	Post		10.526119	76.219886	OH	Racoon					0
P13	P14	Post		10.525563	76.219987	OH	Racoon					0
P14	P15	Post		10.525247	76.220039	OH	Racoon			147.12		147.12
P15	AB Navani	AB		10.525252	76.220062	OH	Racoon			2.58		2.58
AB Navani	5-Navani	Navani	LT	10.52513	76.220258	UG	XLPE	150	1	25.35	35	60.35

From Map no	Map no	Pole/transformer/AB	Metering point	Latitude	Longitude	Cable	Cable type	Cable size (sq mm)	No of runs	Mapping distance (m)	Loose distance (m)	Total distance (m)
P15	P16	Post		10.524683	76.220058	OH	Racoon					0
P16	ABL51603, P17	ABL		10.524238	76.220063	OH	Racoon			111.64		111.64
P17	AB CSB, 6-CSB	CSB		10.52423	76.219961	OH	Racoon			11.2		11.2
ABL51603	P18	Post		10.523344	76.220114	OH	Racoon					0
P18	P19	Post		10.523339	76.220133	OH	Racoon			101.2		101.2
P19	ABI51604	ABI		10.523315	76.220583	OH	Racoon			49.33		49.33
ABI51604	G23	Ground		10.52332	76.220634	UG	XLPE	300	1			0
G23	AB Skyline	AB		10.523988	76.220769	UG	XLPE	300	1	82.72	7	89.72
AB Skyline	9-Sky line	Sky line	LT	10.524008	76.220519	UG	XLPE	185	1	27.45	40	67.45
AB Skyline	P20	Post		10.524006	76.220825	OH	Racoon					0
P20	P20-1	Post		10.524272	76.22098	OH	Racoon					0
P20	P21	Post		10.52442	76.22103	OH	Racoon					0
P21	AB Lalitha	AB		10.524462	76.221069	OH	Racoon			63.98		63.98
AB Lalitha	10-Lalitha Heights	Lalitha Heights	LT	10.524604	76.221079	UG	XLPE	150	1	15.74	15	30.74
P19	P22	Post		10.523354	76.219751	OH	Racoon					0
P22	P23	Post		10.523375	76.219537	OH	Racoon			65.39		65.39
P23	RMU st. Thomas	RMU		10.523439	76.21953	UG	XLPE	300	1	7.12	5	12.12
RMU st. Thomas	St. Thomas	St. Thomas	HT	10.523412	76.219395	UG	XLPE	300	1	15.08	9	24.08
RMU st. Thomas	P24	Post		10.523463	76.219564	UG	XLPE	300	1	4.57	10	14.57
P24	P25	Post		10.52379	76.219537	OH	Racoon			36.29		36.29
P25	AB CSB	AB		10.523717	76.219634	OH	Racoon			13.34		13.34
AB CSB	32- CSB	CSB	HT	10.523723	76.220002	UG	XLPE	150	1	40.29	5	45.29

From Map no	Map no	Pole/transformer/AB	Metering point	Latitude	Longitude	Cable	Cable type	Cable size (sq mm)	No of runs	Mapping distance (m)	Loose distance (m)	Total distance (m)
P25	P26	Post		10.524066	76.219449	OH	Racoon					0
P26	P27	Post		10.524635	76.219249	OH	Racoon			98.65		98.65
P27	AB Navani	AB		10.524644	76.219215	OH	Racoon			3.85		3.85
AB Navani	8-Navani	Navani	LT	10.524701	76.21875	UG	XLPE	150	1	51.29	100	151.29
P27	P28	Post		10.524851	76.219216	OH	Racoon					0
P28	P29	Post		10.525396	76.219117	OH	Racoon					0
P29	AB St.mary's	AB		10.525391	76.219075	OH	Racoon			90.04		90.04
AB St.mary's	7- St. Mary's College	St. Mary's College	HT	10.52544	76.219054	UG	XLPE	150	1	5.89	25	30.89
P23	ABL51606	ABL		10.523428	76.217766	OH	Racoon			194.03		194.03
ABL51606	RMU31603	RMU		10.523277	76.217551	UG	XLPE	300	1	28.86	60	88.86
RMU31603	11-DH College Road	DH College Road	LT	10.523287	76.217569	UG	XLPE	300	1	3	10	13
RMU31603	39- DH Solar	DH Solar	LT	10.523288	76.217547	UG	XLPE	300	1	3.44	10	13.44
ABL51606	ABL51605	ABL		10.52341	76.217018	OH	Racoon					0
ABL51605	P30	Post		10.523441	76.216915	OH	Racoon					0
P30	ABI51108	ABI		10.523708	76.216893	OH	Racoon			124.23		124.23
RMU31603	RMU31604	RMU		10.522605	76.216937	UG	XLPE	300	1	139.26		139.26
RMU31604	RMU31605	RMU		10.522602	76.216913	UG	XLPE	300	1	2.65		2.65
RMU31605	12-Dt.HS Palakkal	Dt.HS Palakkal	LT	10.522598	76.216952	UG	XLPE	300	1	4.29		4.29
RMU31605	13-Dt.HS Palakkal	Dt.HS Palakkal	LT	10.522602	76.216966	UG	XLPE	300	1	5.8		5.8
RMU31604	35-Josco	Josco	HT	10.522375	76.217179	UG	XLPE	300	1	36.73	20	56.73

From Map no	Map no	Pole/transformer/AB	Metering point	Latitude	Longitude	Cable	Cable type	Cable size (sq mm)	No of runs	Mapping distance (m)	Loose distance (m)	Total distance (m)
RMU31604	ABL51607	ABL(8-Pole)		10.522852	76.216642	UG	XLPE	300	1	50.3	20	70.3
ABL51607	ABL51609	ABL		10.52289	76.21661	OH	Racoon			8.84		8.84
ABL51609	RMU31606	RMU		10.522594	76.216883	UG	XLPE	300	1		70	70
RMU31606	40- DH	DH	HT	10.522681	76.217206	UG	XLPE	300	1	81.58	20	101.58
RMU31605	G45	Ground		10.522541	76.216843	UG	XLPE	300	1		20	20
G45	P41	Post		10.52212	76.216784	UG	XLPE	300	1			0
P41	G46	Ground		10.522067	76.215925	UG	XLPE	300	1			0
G46	RMU31607	RMU		10.522099	76.215927	UG	XLPE	300	1			0
RMU31607	19- Chemmanur cooperative Office	Chemmanur cooperative Office	HT	10.522215	76.215907	UG	XLPE	300	1	174.98	20	194.98
RMU31604	AB SIB	AB		10.522871	76.216577	UG	XLPE	240	1			0
AB SIB	18- SIB	SIB	HT	10.522302	76.216145	UG	XLPE	240	1	128.05	70	198.05
ABL51607	15-8 Pole 2	8 Pole 2	LT	10.52286	76.21662	OH	Racoon			7.81		7.81
ABL51607	16-8 Pole 3	8 Pole 3	LT	10.522866	76.216585	OH	Racoon			4.3		4.3
ABL51607	14-8 Pole 1, ABL51608	8 Pole 1	LT	10.522861	76.216566	OH	Racoon			2.22		2.22
ABL51607	17-8 Pole 4	8 Pole 4	LT	10.522867	76.216524	OH	Racoon			2.25		2.25
ABL51607	ABI51203	ABI		10.52286	76.21662	OH	Racoon			7.81		7.81
ABL51608	G47	Ground		10.522667	76.216523	UG	XLPE	300	1			0
G47	G48	Ground		10.52254	76.214984	UG	XLPE	300	1			0
G48	G49	Ground		10.522604	76.214463	UG	XLPE	300	1			0
G49	G50	Ground		10.522413	76.214479	UG	XLPE	300	1			0
G50	G51	Ground		10.522065	76.214515	UG	XLPE	300	1			0

From Map no	Map no	Pole/transformer/AB	Metering point	Latitude	Longitude	Cable	Cable type	Cable size (sq mm)	No of runs	Mapping distance (m)	Loose distance (m)	Total distance (m)
G51	AB fashion, 21- Fashion Fabrics	Fashion Fabrics	LT	10.521462	76.214623	UG	XLPE	300	1	373.52		373.52
AB fashion	AB Elite	AB		10.5215	76.214596	OH	Racoon			5.47		5.47
AB Elite	20- Elite Saree	Elite Saree	HT	10.521528	76.214767	UG	XLPE	300	1	18.97	15	33.97
RMU31604	G24	Ground		10.522571	76.216859	UG	XLPE	300	1			0
G24	G25	Ground		10.522487	76.216841	UG	XLPE	300	1			0
G25	G26	Ground		10.521876	76.216855	UG	XLPE	300	1			0
G26	G27	Ground		10.521967	76.217535	UG	XLPE	300	1			0
G27	P31, 22- Ariyagadi	Ariyagadi	LT	10.521823	76.217562	UG	XLPE	300	1	179.3	10	189.3
P31	G28	Ground		10.521535	76.217579	UG	XLPE	300	1			0
G28	G29	Ground		10.521246	76.217578	UG	XLPE	300	1			0
G29	G30	Ground		10.52116	76.217545	UG	XLPE	300	1			0
G30	G34	Ground		10.521	76.217406	UG	XLPE	300	1			0
G34	G35	Ground		10.520539	76.217434	UG	XLPE	300	1			0
G35	G36	Ground		10.519356	76.217582	UG	XLPE	300	1			0
G36	P39, 23- Kuttans, ABL51612	Kuttans, ABL	LT	10.519303	76.21768	UG	XLPE	300	1	299.44		299.44
P39	G37	Ground		10.5194343	76.217882	UG	XLPE	300	1			0
G37	RMU31609, 3	Holy Space Shopping Complex	LT	10.519158	76.21792	UG	XLPE	300	1	43.58	10	53.58
P39	G38	Ground		10.519421	76.218297	UG	XLPE	300	1			0
G38	AB Holy ht	AB		10.519382	76.218312	UG	XLPE	300	1			0
AB holy ht	24	Holy Heights	LT	10.519074	76.218121	UG	XLPE	300	1	131.14	10	141.14
P39	G39	Ground		10.519279	76.217585	UG	XLPE	300	1			0

From Map no	Map no	Pole/transformer/AB	Metering point	Latitude	Longitude	Cable	Cable type	Cable size (sq mm)	No of runs	Mapping distance (m)	Loose distance (m)	Total distance (m)
G39	G40	Ground		10.51921	76.21702	UG	XLPE	300	1			0
G40	P40	Post		10.51909	76.217043	UG	XLPE	300	1	85.76	10	95.76
P40	25	Erinjeri Ariyangadi 2	LT	10.518624	76.21708	OH	Racoon			49.91		49.91
P40	G41	Ground		10.519222	76.217034	UG	XLPE	300	1		10	10
G41	G42	Ground		10.519246	76.217	UG	XLPE	300	1			0
G42	G43	Ground		10.519732	76.216994	UG	XLPE	300	1			0
G43	G44	Ground		10.520466	76.216991	UG	XLPE	300	1			0
G44	ABL51613, 26	High Road	LT	10.520467	76.216897	UG	XLPE	300	1	166.77	10	176.77
ABL51613	RMU30204	RMU		10.520471	76.216853	UG	XLPE	300	1	4.84	20	24.84
P31	P32	Post		10.521971	76.217591	OH	Racoon					0
P32	P33	Post		10.522064	76.2182	OH	Racoon					0
P33	P34	Post		10.522192	76.218879	OH	Racoon					0
P34	P35	Post		10.522335	76.219574	OH	Racoon			237.57		237.57
P35	ABI51610	ABI		10.521651	76.219472	UG	XLPE	300	1	76.48		76.48
P35	P36	Post		10.522419	76.220107	OH	Racoon			59.08		59.08
P36	LBS	LBS		10.52246	76.220099	UG	XLPE	300	1	4.62	10	14.62
LBS	29	CT Plaza	LT	10.522719	76.22011	UG	XLPE	150	1	28.67	15	43.67
P36	AB east	AB		10.52233	76.220224	OH	Racoon			16.15		16.15
AB east	27	East end plaza	LT	10.52179	76.220317	UG	XLPE	300	1	60.59	10	70.59
P36	P37	Post		10.522512	76.220607	OH	Racoon					0
P37	AB adam	AB		10.522553	76.220863	OH	Racoon			84.07		84.07
AB adam	28	Adam bazar	LT	10.521881	76.22077	UG	XLPE	300	1	88.94	10	98.94
AB adam	AB Sadanan	AB		10.522576	76.221005	OH	Racoon			15.75		15.75
AB Sadanan	33	Sadanadhan	LT	10.522869	76.220986	UG	XLPE	300	1	32.48	20	52.48
AB Sadanan	P38	Post		10.522729	76.221508	OH	Racoon			57.6		57.6

From Map no	Map no	Pole/transformer/AB	Metering point	Latitude	Longitude	Cable	Cable type	Cable size (sq mm)	No of runs	Mapping distance (m)	Loose distance (m)	Total distance (m)
P38	AB Park	AB		10.522643	76.221542	OH	Racoon			10.21		10.21
AB Park	30	Park Land	LT	10.522555	76.221681	UG	XLPE	240	1	18.06	40	58.06
P38	G31	Ground		10.522848	76.221787	UG	XLPE	300	1			0
G31	G32	Ground		10.522762	76.221833	UG	XLPE	300	1			0
G32	RMU31608, 38	Shalimar Shopping Complex	LT	10.522423	76.221956	UG	XLPE	300	1	85.8	10	95.8

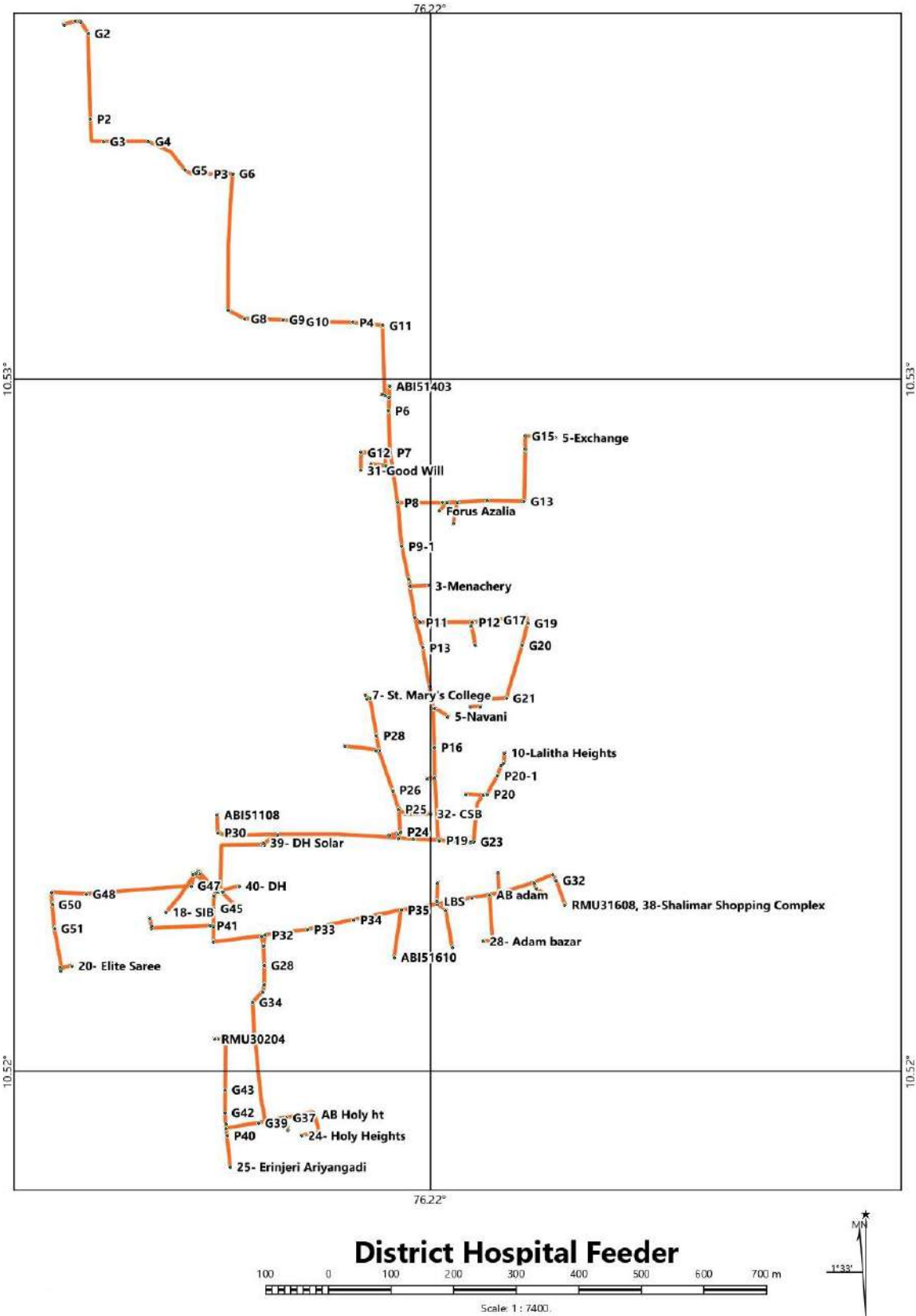

Figure 11: District Hospital feeder

11 ARANATTUKARA FEEDER

The following table shows the 11-kV line distance in the Aranattukara feeder

Table 25: HT line distance – Aranattukara feeder

From Map no	Map no	Pole/transformer/AB	Metering point	Latitude	Longitude	Cable	Cable type	Cable size (sq mm)	No of runs	Mapping distance (m)	Loose distance (m)	Total distance (m)
SS	2P	Post		10.535215	76.214668	UG	XLPE	300	1		21	21
2P	G1	Ground		10.535163	76.215006	UG	XLPE	300	1			0
G1	P1	Post		10.531559	76.215286	UG	XLPE	300	1		21	21
P1	P2	Post		10.530001	76.215078	UG	XLPE	300	1		21	21
P2	G2	Ground		10.529472	76.214997	UG	XLPE	300	1			0
G2	G3	Ground		10.529214	76.216235	UG	XLPE	300	1			0
G3	G4	Ground		10.527413	76.215903	UG	XLPE	300	1			0
G4	G5	Ground		10.526990	76.216700	UG	XLPE	300	1			0
G5	8P	Post		10.522750	76.216537	UG	XLPE	300	1		21	21
8P	G6	Ground		10.522704	76.213044	UG	XLPE	300	1			0
G6	G7	Ground		10.522216	76.212836	UG	XLPE	300	1			0
G7	P3	Post		10.522260	76.212540	UG	XLPE	300	1		21	21
P3	G8	Ground		10.522255	76.212205	UG	XLPE	300	1			0
G8	G9	Ground		10.521833	76.212192	UG	XLPE	300	1			0
G9	G10	Ground		10.521627	76.211648	UG	XLPE	300	1			0
G10	G11	Ground		10.521122	76.211478	UG	XLPE	300	1			0
G11	RMU1	RMU 30501		10.521182	76.211154	UG	XLPE	300	1	2385.97	6	2391.97
RMU1	G12	Ground		10.521037	76.210189	UG	XLPE	300	1			0
G12	G13	Ground		10.521635	76.210142	UG	XLPE	300	1			0
G13	P4	Post		10.521565	76.209426	UG	XLPE	300	1		15	15

From Map no	Map no	Pole/transformer/AB	Metering point	Latitude	Longitude	Cable	Cable type	Cable size (sq mm)	No of runs	Mapping distance (m)	Loose distance (m)	Total distance (m)
P4	G14	Ground		10.521475	76.208831	UG	XLPE	300	1			0
G14	G15	Ground		10.522062	76.208758	UG	XLPE	300	1			0
G15	RMU2, 1	RMU30502, Mothimahal	HT	10.522028	76.208538	UG	XLPE	300	1	411.81	7	418.81
RMU2	G16	Ground		10.523465	76.208386	UG	XLPE	300	1			0
G16	P5	Post		10.523450	76.208140	UG	XLPE	300	1	210.95	6	216.95
P5	AB1	ABI-50504		10.523503	76.208362	OH	Racoon			23.75		23.75
P5	P6	Post		10.523345	76.207798	OH	Racoon			38.55		38.55
P6	RMU3, 3	RMU30503, Ambilikala arcade	LT	10.523092	76.20785	UG	XLPE	240	1	36.79	10	46.79
P6	P7	Post		10.523351	76.207419	OH	Racoon			42.47		42.47
P7	AB2	ABI-50505		10.523530	76.207403	OH	Racoon			21.89		21.89
P7	P8	Post		10.523301	76.207227	OH	Racoon			21.01		21.01
P8	G17	Ground		10.523400	76.207214	UG	XLPE	300	1	1	5	5
G17	G18	Ground		10.523458	76.207695	UG	XLPE	300	1	1		0
G18	RMU4, 5	RMU30504, VRM tower	LT	10.523568	76.207642	UG	XLPE	240	1	1	5	82.56
P8	AB3, 16	ABL50506, Krishnamani	LT	10.523132	76.206512	OH	Racoon			80.46		80.46
AB3	G19	Ground		10.522531	76.206568	UG	XLPE	300	1	1	5	5
G19	G20	Ground		10.521615	76.206271	UG	XLPE	300	1	1		0
G20	G21	Ground		10.521444	76.206117	UG	XLPE	300	1	1		0
G21	G22	Ground		10.520914	76.206188	UG	XLPE	300	1	1		0
G22	AB4	AB		10.520901	76.206123	UG	XLPE	300	1	1		261.49
AB4	17	Pentarc	LT	10.520835	76.205969	UG	XLPE	240	1	1	6	31.51
AB4	P9	Post		10.520544	76.206294	OH	Racoon			42.54		42.54

From Map no	Map no	Pole/transformer/AB	Metering point	Latitude	Longitude	Cable	Cable type	Cable size (sq mm)	No of runs	Mapping distance (m)	Loose distance (m)	Total distance (m)
P9	7	Ashtapati Apartment	LT	10.520564	76.206686	UG	XLPE	240	1	1	10	52.97
P9	P10	Post		10.519624	76.206359	OH	Racoon			103.04		103.04
P10	G23	Ground		10.519842	76.207483	UG	XLPE	300	1	1		0
G23	G24	Ground		10.519936	76.207573	UG	XLPE	300	1	1		0
G24	P11	Post		10.519851	76.208238	UG	XLPE	300	1	1	7	7
P11	10, 14	Routh Tower1,2	HT,LT	10.519273	76.208162	UG	XLPE	300	1	1	20	297.57
AB3	P12	Post		10.523073	76.206092	OH	Racoon			46.43		46.43
P12	P12-1	Post		10.522999	76.206074	OH	Racoon			8.41		8.41
P12-1	18, 19, 20	Centre Point 1, 2, 3	HT, HT, LT	10.522742	76.206013	UG	XLPE	300	1	1	25	54.2
P12	P13	Post		10.522936	76.205722	OH	Racoon			43.24		43.24
P13	P13-1	Post		10.523000	76.205729	UG	XLPE	300				0
P13-1	RMU	RMU-PCK		10.523205	76.20594	UG	XLPE	300				0
RMU	PCK	PCK - NewTransformer	LT	10.523276	76.205962	UG	XLPE	300		47.7	10	57.7
P13	RMU5	RMU		10.523216	76.205909	UG	XLPE	300	1	1		0
P13	P14	Post		10.522925	76.205646	OH	Racoon			8.41		8.41
P14	P14-1	Post		10.523083	76.205618	OH	Racoon			17.74		17.74
P14-1	22	Kochu Bhavan	LT	10.523412	76.205606	OH	Racoon			36.41		36.41
P14-1	21	HDFC	LT	10.523152	76.205462	UG	XLPE	300	1	1	15	33.7
P14	P15	Post		10.522848	76.205287	OH	Racoon			40.21		40.21
P15	23	Colour House	HT	10.523379	76.205255	UG	XLPE	300	1	1	6	64.84
P15	AB5,9	ABL50507, Spoon	LT	10.522442	76.205269	UG	XLPE	300	1	1	3	47.95
AB5	P16	Post		10.522219	76.205282	OH	Racoon			24.71		24.71
P16	P16-1	Post		10.522207	76.205119	OH	Racoon					0
P16-1	11	Income Tax Office	HT	10.522135	76.205009	UG	XLPE	300	1	1	15	47.33

From Map no	Map no	Pole/transformer/AB	Metering point	Latitude	Longitude	Cable	Cable type	Cable size (sq mm)	No of runs	Mapping distance (m)	Loose distance (m)	Total distance (m)
P16	P17	Post		10.5217	76.2052	OH	Racoon			57.69		57.69
P17	42	P17-1, Parayil Lane	LT	10.521738	76.205124	OH	Racoon			9.55		9.55
P17-1	24	Presidency	LT	10.521691	76.205091	OH	Racoon			6.33		6.33
P17	P18	Post		10.521047	76.205065	OH	Racoon					0
P18	P18-1	Post		10.521012	76.205132	OH	Racoon			84.06		84.06
P18-1	41	Jaya Lakshmi Silks	HT	10.520846	76.205440	UG	XLPE	300	1	1	20	58.39
P15	P19	Post		10.522612	76.204097	OH	Racoon			132.85		132.85
P19	P19-1	Post		10.522820	76.204111	OH	Racoon			23.06		23.06
P19-1	25	Malabar Gold	HT	10.523029	76.204109	UG	XLPE	300	1	1	30	53.12
P19	P20	4P		10.522539	76.203786	OH	Racoon			34.99		34.99
P20	G25	Ground		10.522279	76.202415	UG	XLPE	300	1	1		0
G25	AB6	ABL-50508		10.521607	76.201725	UG	XLPE	300	1	1		260.22
AB6	AB7	ABI-50509		10.521668	76.201755	OH	Racoon			7.5		7.5
AB6	P21	Post		10.520268	76.200788	OH	Racoon			180.2		180.2
P21	P21-1	Post		10.520191	76.200923	OH	Racoon			17.06		17.06
P21-1	8	Link Offset	HT	10.519930	76.201387	UG	XLPE	300	1	58.42	10	68.42
P21	P22	Post		10.519674	76.200391	OH	Racoon			78.77		78.77
P22	30	MRG Samyuktha Apartment	LT	10.519657	76.200526	OH	Racoon			14.9		14.9
30	31	VIP Apartment	LT	10.519698	76.200590	OH	Racoon			8.35		8.35
P22	29	Mental Hospital	LT	10.518809	76.199680	OH	Racoon			128.47		128.47
29	6	Nethaji Ground	LT	10.518756	76.199638	OH	Racoon			7.45		7.45
6	P23	Post		10.518716	76.199710	OH	Racoon					0
P23	AB8	ABL-50510		10.515662	76.197337	OH	Racoon					0
AB8	32	Toppin Moola	LT	10.515453	76.197162	OH	Racoon			465.19		465.19

From Map no	Map no	Pole/transformer/AB	Metering point	Latitude	Longitude	Cable	Cable type	Cable size (sq mm)	No of runs	Mapping distance (m)	Loose distance (m)	Total distance (m)
P24	G26	Ground		10.515538	76.197057	UG	XLPE	300	1		7	7
G26	RMU6	RMU-30505		10.516758	76.197205	UG	XLPE		1			0
RMU6	G27	Ground		10.516049	76.197107	UG	XLPE		1			0
G27	RMU7	RMU-30506		10.516053	76.196997	UG	XLPE		1			0
RMU7	2	Confident Gemini	LT	10.515849	76.196713	UG	XLPE	300	1	280.34	10	290.34
P24	P25, AB9	ABL-50512		10.515273	76.196968	OH	Racoon					0
P25	P26	Post		10.513641	76.196896	OH	Racoon					0
P26	AB10	ABL-50513		10.513643	76.195624	OH	Racoon			349.04		349.04
AB10	33	Malayalam School	LT	10.513620	76.195484	OH	Racoon			15.53		15.53
AB10	P27,34	Arnattukkara market	LT	10.511747	76.195637	OH	Racoon			209.36		209.36
P27	G28	Ground		10.511771	76.194854	UG	XLPE		1			0
G28	G29	Ground		10.510590	76.194788	UG	XLPE		1			0
G29	P28	Post		10.510578	76.194679	UG	XLPE		1	236.01	7	243.01
P28	P29, 35	Laloor	LT	10.510596	76.194569	OH	Racoon			12.2		12.2
P24	AB11	ABL-50511		10.515429	76.197368	OH	Racoon					0
AB11	P30	Post		10.515287	76.198153	OH	Racoon			110.06		110.06
P30	RMU8, 38	RMU-30507, Global Plaza	LT	10.515342	76.198183	UG	XLPE	300	1	6.91	3	9.91
RMU8	G30	Ground		10.515149	76.198557	UG	XLPE		1			0
G30	RMU9	RMU-30508		10.515246	76.198603	UG	XLPE		1			0
RMU9	39	Le-shore	LT	10.515318	76.198633	UG	XLPE	300	1	67.98		67.98
P30	P31, 37	Maani	LT	10.514893	76.199786	OH	Racoon			183.99		183.99
P31	RMU10	RMU-30509		10.514864	76.199485	UG	XLPE		1			0
RMU10	40	Govind Green Apartment	LT	10.514641	76.199411	UG	XLPE	300	1	59.07	3	62.07

From Map no	Map no	Pole/transformer/AB	Metering point	Latitude	Longitude	Cable	Cable type	Cable size (sq mm)	No of runs	Mapping distance (m)	Loose distance (m)	Total distance (m)
P31	AB12	ABL-50514		10.514480	76.201325	OH	Racoon					0
AB12	P32	Post		10.514363	76.201952	OH	Racoon			244.26		244.26
P32	AB13	AB		10.514243	76.201924	OH	Racoon					0
AB	P32-1	Post		10.513617	76.201764	OH	Racoon					0
P32-1	P32-2	Post		10.513538	76.201674	OH	Racoon					0
P32-2	P32-3	Post		10.510629	76.200810	OH	Racoon					0
P32-3	15	Kizhakkepuram	LT	10.510575	76.200007	OH	Racoon			530.27		530.27
P32	P33	Post		10.514337	76.202154	OH	Racoon			22.3		22.3
P33	36	AAZ Complex	LT	10.514248	76.202092	OH	ABC			11.96		11.96
P33	P34,	AB14		10.513776	76.204230	OH	Racoon					
P34	P35, 13	Excise	LT	10.513751	76.204350	OH	Racoon			249.12		249.12
P35	P36	Post		10.513684	76.204492	OH	Racoon			17.22		17.22
P34	G31	Ground		10.513999	76.203284	UG	XLPE	300	1		5	5
G31	27	Sai Service	HT	10.513457	76.203194	UG	XLPE		1	201.58		201.58
P36	P36-1	Post		10.514265	76.204405	OH	Racoon			64.97		64.97
P36-1	12	Cheloor	LT	10.514544	76.203703	UG	XLPE	300	1	82.81	7	89.81
P37	P38	Post		10.513720	76.204846	OH	Racoon			1.92		1.92
P38	28	C A Arcade	LT	10.513666	76.204990	UG	XLPE	300	1	16.86	7	23.86
P36	P37	Post		10.513729	76.204831	OH	Racoon			37.66		37.66
P37	P37-1	Post		10.513586	76.204770	OH	Racoon			17.17		17.17
P37-1	26	Excise Acadamy	HT	10.513397	76.204839	UG	XLPE	300	1	22.23	21	43.23
P38	P39	Post		10.513800	76.205778	OH	Racoon					0
P39	P40,4	P&T Pothole	LT	10.514221	76.206040	OH	Racoon			157.78		157.78
P40	RMU11	RMU-30302		10.514276	76.207032	UG	XLPE	300	1	112.17	5	117.17

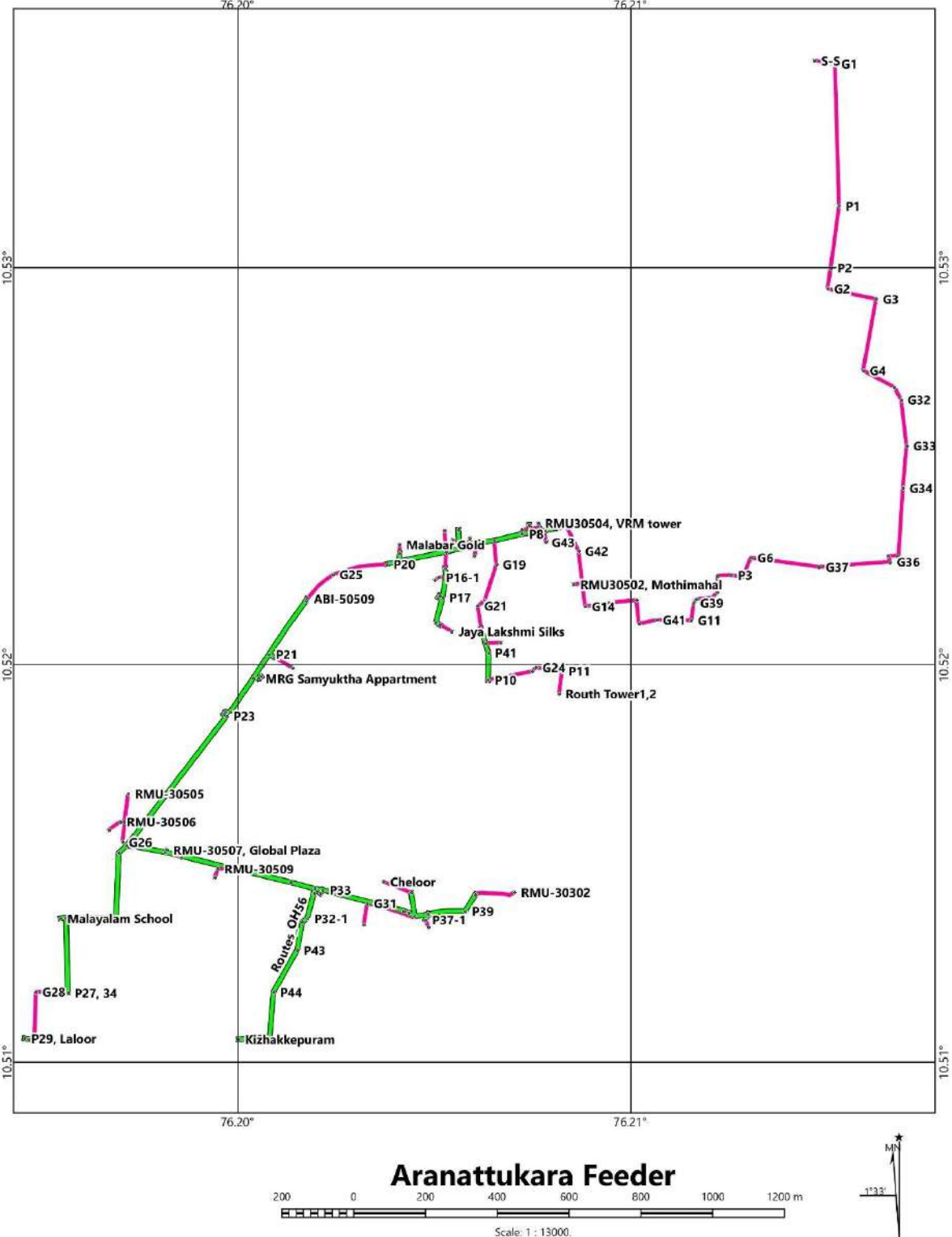

Figure 12: Arnattukara feeder

12 KOTTAPURAM FEEDER

The following table shows the 11-kV line distance in the Kottapuram feeder

Table 26: HT line distance –Kottapuram feeder

From Map no	Map no	Pole/transformer/AB	Metering point	Latitude	Longitude	Cable	Cable type	Cable size (sq mm)	No of runs	Mapping distance (m)	Loose distance (m)	Total distance (m)
	S-S	Substation feeder		10.53517	76.21455							
SS	2P	Post		10.535262	76.214493	UG	XLPE	300	1		16	16
2P	G1	Ground		10.535309	76.214497	UG	XLPE	300	1			0
G1	P1	Post		10.535347	76.211859	UG	XLPE	300	1	306.02	10	316.02
P1	ABL51302	ABL		10.535252	76.211305	OH	Racoon		1	61.54		61.54
ABL51302	G2	Ground		10.535342	76.211239	UG	XLPE	300	1		7	7
G2	ABL50906	ABL		10.535331	76.207935	UG	XLPE	300	1		7	7
ABL50906	G3	Ground		10.535289	76.205362	UG	XLPE	300	1			0
G3	ABL51305	ABL		10.535203	76.205368	UG	XLPE	300	1	665.14	7	672.14
ABL51305	P2	Post		10.535047	76.205354	OH	Racoon			17.12		17.12
P2	AB ARikkariya	AB		10.535052	76.205424	OH	Racoon			7.68		7.68
AB Arikkariya	1	Arikkariya	LT	10.534980	76.205692	UG	XLPE	300	1	30.4	7	37.4
P2	P9, ABL51306	ABL		10.533987	76.205074	OH	Racoon			121.19		121.19
ABL51306	2	Rama Devi	LT	10.533919	76.205709	OH	Racoon			69.91		69.91
2	P3	Post		10.533871	76.206127	OH	Racoon			46.06		46.06
P3	P4	Post		10.533967	76.20618	OH	Racoon			12.1		12.1
P4	AB Mookambika	AB		10.533993	76.206134	OH	Racoon			5.8		5.8

From Map no	Map no	Pole/transformer/AB	Metering point	Latitude	Longitude	Cable	Cable type	Cable size (sq mm)	No of runs	Mapping distance (m)	Loose distance (m)	Total distance (m)
AB Mookambika	3	Mookambika	LT	10.534021	76.206123	UG	XLPE	150	1	3.32	40	43.32
P4	RMU31301	RMU		10.534310	76.206270	UG	XLPE	300	1			0
RMU31301	57	Tangerine	LT	10.53429	76.206290	UG	XLPE	300	1	43.25	10	53.25
P3	4	Rama Devi 3	LT	10.533827	76.206238	OH	Racoon			13.09		13.09
4	P5	Post		10.533748	76.206853	OH	Racoon			68.3		68.3
P5	15	Vigneshwara	LT	10.532767	76.206776	UG	XLPE	300	1	108.84	5	113.84
P5	ABL51307	ABL		10.533700	76.207387	OH	Racoon		1	58.7		58.7
ABL51307	G4	Ground		10.534289	76.207404	UG	XLPE	300	1			0
G4	RMU31302	RMU		10.534287	76.207566	UG	XLPE	300	1	82.91		82.91
RMU31302	52	Maithree Apartment	LT	10.534294	76.207746	UG	XLPE	185	1	19.72	5	24.72
RMU31302	RMU31303	RMU		10.534267	76.207355	UG	XLPE	300	1			0
RMU31303	64	MRG Sabari	LT	10.534170	76.207164	UG	XLPE	300	1	46.7		46.7
ABL51307	P6	Post		10.533629	76.207678	OH	Racoon			32.99		32.99
P6	P7, ABL51308	ABL		10.533174	76.207687	OH	Racoon			50.37		50.37
P7	AB Kayson	AB		10.533137	76.207609	OH	Racoon			9.47		9.47
AB Kayson	5	Kayson Apartmemnt	LT	10.533200	76.207395	UG	XLPE	185	1	24.44	7	31.44
ABL51308	RMU31305	RMU		10.533070	76.207253	UG	XLPE	300	1	53.97		53.97
RMU31305	50	Samruthi Apartment	LT	10.533116	76.207013	UG	XLPE	185	1	26.76	10	36.76
RMU31305	G5	Ground		10.532483	76.207279	UG	XLPE	300	1			0
G5	RMU31306	RMU		10.532488	76.207234	UG	XLPE	300	1	69.95		69.95
RMU31306	51	Sree Ram Apartment	LT	10.532283	76.207158	UG	XLPE	300	1	24.15	15	39.15
RMU31306	G6	Ground		10.531985	76.207244	UG	XLPE	300	1			0

From Map no	Map no	Pole/transformer/AB	Metering point	Latitude	Longitude	Cable	Cable type	Cable size (sq mm)	No of runs	Mapping distance (m)	Loose distance (m)	Total distance (m)
G6	G7	Ground		10.531891	76.207096	UG	XLPE	300	1			0
G7	RMU31307	RMU		10.531845	76.206929	UG	XLPE	300	1			0
RMU31307	56	Indivar	LT	10.531922	76.206980	UG	XLPE	300	1	104.06	15	119.06
P6	P8	Post		10.53362376	76.207765	OH	Racoon		1	9.54		9.54
P8	19	Vykundam	LT	10.533540	76.20777	UG	XLPE	300	1	9.29		9.29
P6	RMU31304	RMU		10.533765	76.208144	UG	XLPE	300	1			0
RMU31304	66	Kalyan Heritage	LT	10.533979	76.208074	UG	XLPE	300	1	69.21		69.21
P9	P10	Post		10.533612	76.205038	OH	Racoon			41.87		41.87
P10	AB Omega	AB		10.533536	76.204918	OH	Racoon			15.59		15.59
AB Omega	6	Omega royal	LT	10.533446	76.204785	UG	XLPE	300	1	17.64	15	32.64
P10	7	Prarthana	LT	10.533234	76.205020	OH	Racoon			41.87		41.87
7	P11	Post		10.532472	76.204971	OH	Racoon			84.81		84.81
P11	RMU31308	RMU		10.532427	76.204994	UG	XLPE	300	1			0
RMU31308	44	IRA Apartment	LT	10.532450	76.205137	UG	XLPE	300	1	21.44	40	61.44
P11	P12	Post		10.531041	76.204957	OH	Racoon					0
P12	P13	Post		10.530996	76.203989	OH	Racoon			264.36		264.36
P13	P14	Post		10.531333	76.203826	OH	Racoon					0
P14	ABL51309	ABL		10.531577	76.203536	OH	Racoon					0
ABL51309	P15	Post		10.531666	76.202435	OH	Racoon			203.9		203.9
P15	18	Aldebaren	LT	10.531978	76.202557	UG	XLPE	300	1	37		37
P15	AB Athira	AB		10.531560	76.202466	OH	Racoon			12.21		12.21
AB Athira	17	Athira Abode	LT	10.531127	76.202366	UG	XLPE	300	1	49.13		49.13
P15	P16	Post		10.531697	76.201994	OH	Racoon			48.39		48.39
P16	21	Cheloor Citadel	LT	10.531095	76.202126	UG	XLPE	300	1	68.14	20	88.14
P13	ABL51310	ABL		10.529424	76.205071	OH	Racoon					0
ABL51310	P17	Post		10.529078	76.205285	OH	Racoon			255.25		255.25

From Map no	Map no	Pole/transformer/AB	Metering point	Latitude	Longitude	Cable	Cable type	Cable size (sq mm)	No of runs	Mapping distance (m)	Loose distance (m)	Total distance (m)
P17	RMU31309	RMU		10.529081	76.205175	UG	XLPE	300	1	12.04		12.04
RMU31309	68	Top Crystal Apartment	LT	10.528966	76.205109	UG	XLPE	150	1	14.63	5	19.63
P17	P18	Post		10.528186	76.205505	OH	Racoon					0
P18	8	Kottappuram Vyduthi Bhavan	LT	10.527899	76.205496	OH	Racoon			135.64		135.64
8	AB Sreesakthi	AB		10.527837	76.205551	OH	Racoon			9.13		9.13
AB Sreesakthi	14	Sreesakthi	LT	10.52792	76.205702	UG	XLPE	300	1	18.91	30	48.91
8	P19	Post		10.527675	76.205462	OH	Racoon			25.05		25.05
P19	G8	Ground		10.527695	76.206803	UG	XLPE	300	1			0
G8	G9	Ground		10.527816	76.206865	UG	XLPE	300	1			0
G9	G10	Ground		10.527889	76.207354	UG	XLPE	300	1			0
G10	G11	Ground		10.527813	76.207395	UG	XLPE	300	1			0
G11	G12	Ground		10.528062	76.207874	UG	XLPE	300	1			0
G12	G13	Ground		10.528313	76.207821	UG	XLPE	300	1			0
G13	9	Ragamalikapuram	LT	10.528318	76.207778	UG	XLPE	300	1	319.01		319.01
P19	P20	Post		10.527153	76.205667	OH	Racoon			61.95		61.95
P20	AB Zodiac	AB		10.527163	76.205516	OH	Racoon			16.57		16.57
AB Zodiac	13	Zodiac	LT	10.527070	76.205368	UG	XLPE	185	1	19.19	15	34.19
P20	ABL51311	ABL		10.526909	76.205723	OH	Racoon			27.68		27.68
ABL51311	AB Vintage, AB Heights	AB		10.526971	76.20585	OH	Racoon			15.5		15.5
AB Vintage	10	Cheloor Vintage	LT	10.527029	76.205899	UG	XLPE	185	1	8.36	25	33.36
AB Heights	20	Cheloor Heights	LT	10.526924	76.206308	UG	XLPE	185	1	51.82	15	66.82

From Map no	Map no	Pole/transformer/AB	Metering point	Latitude	Longitude	Cable	Cable type	Cable size (sq mm)	No of runs	Mapping distance (m)	Loose distance (m)	Total distance (m)
ABL51311	P21	Post		10.52669	76.204511	OH	Racoon			134.86		134.86
P21	P22	Post		10.526675	76.20447	OH	Racoon			4.78		4.78
P22	G14	Ground		10.527135	76.204398	UG	XLPE	185	1			0
G14	RMU31310	RMU		10.527117	76.204354	UG	XLPE	185	1			0
RMU31310	55	Vaigai	LT	10.527256	76.204299	UG	XLPE	185	1	73.21	7	80.21
P21	48	Swetha	LT	10.527805	76.204279	UG	XLPE	185	1	125.92		125.92
P22	ABI51803	ABI		10.526442	76.204098	OH	Racoon			48.19		48.19
ABL51311	P23, AB Achuthan	AB		10.526418	76.205919	OH	Racoon			58.39		58.39
AB Achuthan	49	Achutan	LT	10.526395	76.206129	UG	XLPE	300	1	23.13	7	30.13
P23	P23-1	Post		10.526237	76.206023	OH	Racoon		1	23.03		23.03
P23-1	G17	Ground		10.526357	76.206363	UG	XLPE	300	1			0
G17	RMU31311	RMU		10.526423	76.20638	UG	XLPE	300	1			0
RMU31311	65	Civanta Apartment	LT	10.526538	76.206395	UG	XLPE	300	1	59.87	10	69.87
P23-1	P24	Post		10.525827	76.206114	OH	Racoon			46.43		46.43
P24	AB Sivapuri	AB		10.525818	76.206156	OH	Racoon			4.7		4.7
AB Sivapuri	G15	Ground		10.526031	76.207069	UG	XLPE	300	1		7	7
G15	G16	Ground		10.526211	76.207058	UG	XLPE	300	1			0
G16	RMU31312	RMU		10.526294	76.207482	UG	XLPE	300	1			0
RMU31312	60	SivaPuri	LT	10.526182	76.207508	UG	XLPE	300	1	182.4	35	217.4
P24	P25	Post		10.525516	76.206109	OH	Racoon					0
P25	P26	Post		10.525294	76.206139	OH	Racoon			59.18		59.18
P26	AB Pankaj	AB		10.525298	76.206247	OH	Racoon			11.83		11.83
AB Pankaj	16	Pankaj	LT	10.525285	76.206324	UG	XLPE	300	1	8.55	7	15.55
P26	AB Velan, 11	Vellan	LT	10.524298	76.206639	OH	Racoon			130.58		130.58

From Map no	Map no	Pole/transformer/AB	Metering point	Latitude	Longitude	Cable	Cable type	Cable size (sq mm)	No of runs	Mapping distance (m)	Loose distance (m)	Total distance (m)
AB Velan	P26	Post		10.524327	76.206729	OH	Racoon			10.36		10.36
P26	AB Love Dale	AB		10.524357	76.206794	OH	Racoon			7.85		7.85
AB Love Dale	12	Love Dale	LT	10.524454	76.206703	UG	XLPE	185	1	14.64	7	21.64
AB Velan	G18, P27	Ground, Post		10.524344	76.206840	UG	XLPE	300	1			0
G18	RMU31313	RMU		10.524019	76.207042	UG	XLPE	300	1			0
RMU31313	63	Nandana Plaza	LT	10.524007	76.206946	UG	XLPE	300	1	75.38	15	90.38
AB Love Dale	P27	Post		10.524344	76.206840	OH	Racoon					0
P27	ABI50505	ABI		10.523436	76.207412	OH	Racoon			128.07		128.07

13 VANCHIKULAM FEEDER

The following table shows the 11-kV line distance in the Vanchikulam feeder

Table 27: HT line distance –Vanchikulam feeder

From Map no	Map no	Pole/transformer/AB	Metering point	Latitude	Longitude	Cable	Cable type	Cable size (sq mm)	No: of runs	Mapping distance (m)	Loose distance (m)	Total distance (m)
	S-S	Substation feeder		10.535141	76.214580							
S-S	2P	Post		10.535240	76.214450	UG	XLPE	300	1		21	21
2P	G1	Ground		10.535338	76.214386	UG	XLPE	300	1			0
G1	ABL51801	ABL		10.535333	76.208329	UG	XLPE	300	1	693.81	7	700.81
ABL51801	P1	Post		10.535269	76.205362	OH	ABC				35	35
P1	P2	Post		10.531027	76.204970	OH	ABC				7	7
P2	P3	Post		10.530969	76.203991	OH	ABC				7	7
P3	P4	Post		10.528711	76.205460	OH	ABC					0
P4	P5	Post		10.527897	76.205469	OH	ABC					0
P5	P6	Post		10.526910	76.205759	OH	ABC					0
P6	ABL	ABL51802, ABL51805, ABI51804, ABI51803		10.526442	76.204098	OH	ABC			1593.17		1593.17
ABL51802	P7	Post		10.525726	76.202361	OH	Racoon					0
P7	P8	Post		10.525438	76.202443	OH	Racoon			239.06		239.06
P8	1-Raya Complex	Transformer	LT	10.525474	76.202501	OH	Racoon			7.49		7.49
P8	P9	Post		10.524369	76.202870	OH	Racoon					0

From Map no	Map no	Pole/transformer/AB	Metering point	Latitude	Longitude	Cable	Cable type	Cable size (sq mm)	No: of runs	Mapping distance (m)	Loose distance (m)	Total distance (m)
P9	2-Shankaraiyar Road	Transformer	LT	10.524188	76.202998	OH	Racoon				151.58	151.58
2	ABL51806	ABL		10.522871	76.203785	OH	Racoon			169.24		169.24
ABL51806	3, 4-Modern	Transformer	LT, HT	10.522873	76.203578	UG	XLPE	300	1	22.66	7	29.66
ABL51806	ABL	ABL		10.522549	76.203789	OH	Racoon			35.62		35.62
ABL	RMU31802	RMU		10.522452	76.203724	UG	XLPE	300	1			0
RMU31802	11-WestPlaza	Transformer	HT	10.522330	76.203834	UG	XLPE	300	1	30.96	30	60.96
ABL	P10	Post		10.522545	76.203552	OH	Racoon			25.95		25.95
P10	8, 7-Grand mall	Transformer	LT,HT	10.522147	76.203596	UG	XLPE	300	1	44.29		44.29
P10	ABL51807	ABL		10.522497	76.203414	OH	Racoon			16.01		16.01
ABL51807	G2	Ground		10.522465	76.203329	UG	XLPE	300	1			0
G2	AB Maruthi	Transformer		10.521939	76.203324	UG	XLPE	300	1	71.63	7	78.63
AB Maruthi	9-Bhuvari Tower	Transformer	HT	10.522290	76.203373	UG	XLPE	300	1	39.7		39.7
ABL	G2	Ground		10.522465	76.203329	UG	XLPE	300	1			0
G2	AB Maruthi, 10	Transformer-Maruthi Apartment	LT	10.521939	76.203324	UG	XLPE	300	1	71.63		71.63

From Map no	Map no	Pole/transformer/AB	Metering point	Latitude	Longitude	Cable	Cable type	Cable size (sq mm)	No: of runs	Mapping distance (m)	Loose distance (m)	Total distance (m)
ABL51807	G3	Ground		10.522356	76.202578	UG	XLPE	300	1			0
G3	RMU31801	RMU		10.522315	76.202581	UG	XLPE	300	1			0
RMU31801	6-K K Tower	Transformer	HT	10.522103	76.202473	UG	XLPE	300	1	123.64	20	143.64
ABL	P11	Post		10.522476	76.203000	OH	Racoon					0
P11	AB Salfloa	AB		10.522604	76.202982	OH	Racoon			59.67		59.67
AB Salfloa	5-Salfloa	Transformer	HT	10.522735	76.202979	UG	XLPE	240	1	14.49	7	21.49
ABL	P12	Post		10.522446	76.204041	OH	Racoon					0
P12	P13	Post		10.522052	76.204270	OH	Racoon			80.12		80.12
P13	14-Fimat	Transformer	LT	10.522134	76.204357	OH	Racoon			13.15		13.15
14	RMU31803	RMU		10.522177	76.204343	UG	XLPE	300	1		7	7
RMU31803	12, 13 Sunny Diamonds	Transformer	LT,HT	10.522283	76.204424	UG	XLPE	300	1	19.7		19.7
P13	P13-1	ABL		10.520997	76.204906	OH	Racoon			135.88		135.88
P13-1	15-Hawa	Transformer	LT	10.520798	76.204829	OH	Racoon			23.57		23.57
15	ABL51809	ABL		10.520762	76.204816	OH	Racoon					0
ABL51809	AB Fathima, RMU31804	RMU		10.520552	76.204744	OH	Racoon			28.76		28.76
RMU31804	16-Fathima	Transformer	HT	10.520512	76.204599	UG	XLPE	300	1	16.48	30	46.48
AB Fathima	AB	AB		10.519734	76.204899	OH	Racoon			92.79		92.79

From Map no	Map no	Pole/transformer/AB	Metering point	Latitude	Longitude	Cable	Cable type	Cable size (sq mm)	No: of runs	Mapping distance (m)	Loose distance (m)	Total distance (m)
AB	G3-1	Ground		10.519725	76.203984	UG	XLPE	300	1			0
G3-1	AB Bhavani	AB		10.519334	76.204054	UG	XLPE	300	1	144.08	7	151.08
AB Bhavani	17-Bhavani	Transformer	LT	10.519385	76.204207	UG	XLPE	150	1	17.67	15	32.67
AB	P14	Post		10.519521	76.204974	OH	Racoon			24.95		24.95
P14	AB Sudharsan	AB		10.519561	76.205042	OH	Racoon			8.66		8.66
AB Sudharsan	18-Sudharsan	Transformer	LT	10.519421	76.205210	UG	XLPE	150	1	24.04	10	34.04
P14	P15	Post		10.519135	76.205074	OH	Racoon			44.08		44.08
P15	AB Commercial	AB		10.519124	76.205162	OH	Racoon			9.71		9.71
AB Commercial	19-Commercial	Transformer	HT	10.519285	76.205441	UG	XLPE	240	1	35.35		35.35
P15	P15-1	Post		10.518561	76.205318	UG	XLPE	300		64.89		64.89
P15-1	RMU TBPL	RMU		10.518533	76.20532	UG	XLPE	300				0
RMU TBPL	TBPL RIO	Transformer	LT	10.518664	76.205022	UG	XLPE	300		42.69	11	53.69
P15	P16	Post		10.518308	76.205355	OH	Racoon					0
P16	20-Kaveri Apartment	Transformer	LT	10.518277	76.204844	OH	Racoon			152.64		152.64
P13-1	AB Level10	AB		10.520339	76.205264	OH	Racoon			82.66		82.66
AB Level10	RMU31805	RMU		10.520305	76.205232	UG	XLPE	240	1			0

From Map no	Map no	Pole/transformer/AB	Metering point	Latitude	Longitude	Cable	Cable type	Cable size (sq mm)	No: of runs	Mapping distance (m)	Loose distance (m)	Total distance (m)
RMU31805	22-Level10	Transformer	HT	10.520343	76.205077	UG	XLPE	240	1	22.62	10	32.62
AB Level10	ABL51810	ABL		10.519831	76.205564	OH	Racoon			65.08		65.08
ABL51810	AB Art	AB		10.519933	76.205627	OH	Racoon			13.22		13.22
AB Art	21-Art of living	Transformer	LT	10.520020	76.205730	UG	XLPE	240	1	14.98	30	44.98
ABL51810	23-Refrigeration	Transformer	LT	10.519344	76.205920	OH	Racoon			67.64		67.64
23-Refrigeration	P17	Post		10.519135	76.206029	OH	Racoon			26.02		26.02
P17	24-Sainic Gas	Transformer	LT	10.519319	76.206364	OH	ABC			41.94	15	56.94
P17	P18	Post		10.518286	76.206461	OH	Racoon			108.92		108.92
P18	AB LIC	AB		10.518274	76.206422	UG	XLPE	300	1	4.47		4.47
AB LIC	25-LIC	Transformer	LT	10.518275	76.206237	UG	XLPE	240	1	20.25	30	50.25
P18	RMU31806, 26-	RMU, South Plaza	LT	10.518208	76.206365	UG	XLPE	300	1	13.6		13.6
P18	ABL51811	ABL		10.517656	76.206858	OH	Racoon					0
ABL51811	AB Sitaram, P19	Post		10.516947	76.207224	OH	Racoon			172.73		172.73
AB Sitaram	G4	Ground		10.517037	76.207175	UG	XLPE	185	1		10	10
G4	G5	Ground		10.515960	76.205012	UG	XLPE	185	1			0

From Map no	Map no	Pole/transformer/AB	Metering point	Latitude	Longitude	Cable	Cable type	Cable size (sq mm)	No: of runs	Mapping distance (m)	Loose distance (m)	Total distance (m)
G5	27-Sitharam Heritage	Transformer	LT	10.515834	76.205024	UG	XLPE	185	1	290.35	10	300.35
P19	RMU31807, 28-KMJ	Transformer	LT	10.516881	76.207142	UG	XLPE	300	1	11.57	15	26.57
P19	P20	Post		10.516740	76.207317	OH	Racoon			25.06		25.06
P20	AB Merlin	AB		10.516799	76.207389	OH	Racoon			10.23		10.23
AB Merlin	29-Merlin Hotel	Transformer	HT	10.517279	76.207969	UG	XLPE	150	1	82.76	15	97.76
P20	P21	Post		10.516293	76.207464	OH	Racoon					0
P21	P22, 31-State Hotel	Transformer	LT	10.515777	76.207415	OH	Racoon			109.32		109.32
P22	G6	Ground		10.515717	76.206668	UG	XLPE	300	1		7	7
G6	30-Global Plaza/Global Tower	Transformer	LT	10.515624	76.206674	UG	XLPE	300	1	94.61	10	104.61
P22	G7	Ground		10.515433	76.207315	UG	XLPE	300	1		7	7
G7	32-Love shore	Transformer	HT	10.515640	76.206920	UG	XLPE	300	1	88.52	15	103.52
P22	P23	Post		10.514557	76.207085	OH	Racoon			139.7		139.7
P23	RMU30302	RMU		10.514212	76.207012	UG	XLPE	300	1	38.99	10	48.99
P23	P24	Post		10.514299	76.206926	OH	Racoon			33.49		33.49

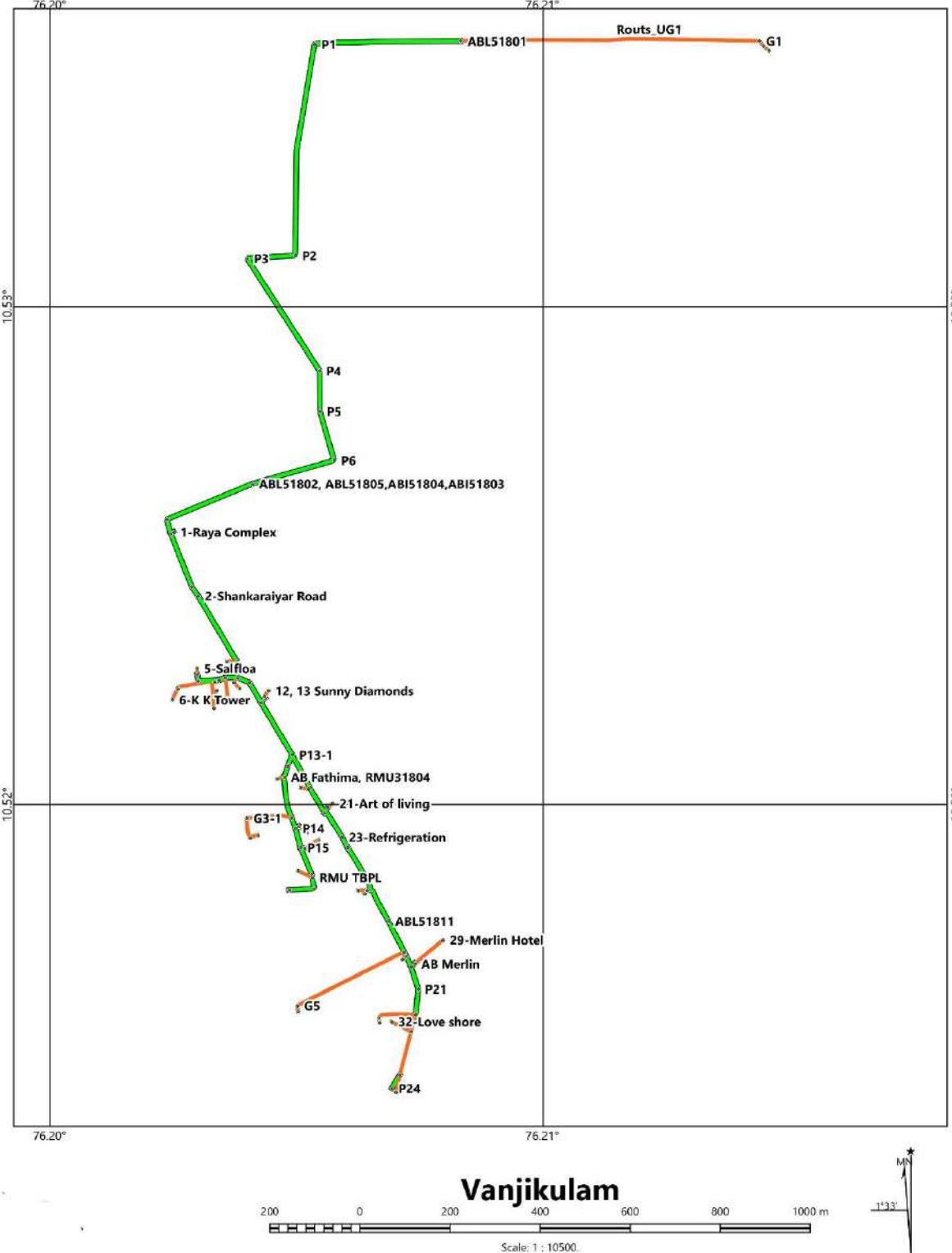

Figure 14: Vanchikulam feeder

14 KERALAVARMA FEEDER

The following table shows the 11-kV line distance in the Keralavarma feeder

Table 28: HT line distance –Keralavarma feeder

From Map no	Map no	Pole/transformer/AB	Metering point	Latitude	Longitude	Cable	Cable type	Cable size (sq mm)	No of runs	Mapping distance (m)	Loose distance (m)	Total distance (m)
	S-S	Substation		10.535170	76.214550							
SS	2P	post		10.535273	76.214431	UG	XLPE	300	1		10	10
2P	G1	Ground		10.535321	76.214428	UG	XLPE	300	1			
G1	G2	Ground		10.535355	76.211746	UG	XLPE	300	1			
G2	G3	Ground		10.535278	76.211385	UG	XLPE	300	1			
G3	G4	Ground		10.535441	76.211058	UG	XLPE	300	1		3	3
G4	G5	Ground		10.535456	76.2083	UG	XLPE	300	1		2	2
G5	G6	Ground		10.535456	76.208774	UG	XLPE	300	1			
G6	P1	post		10.535296	76.208826	UG	XLPE	300	1		5	5
P1	G7	Ground		10.534716	76.208730	UG	XLPE	300	1			
G7	P2	post		10.534159	76.208607	UG	XLPE	300	1		3	3
P2	G8	Ground		10.533560	76.208529	UG	XLPE	300	1			
G8	G9	Ground		10.533887	76.206057	UG	XLPE	300	1			
G9	G10	Ground		10.534050	76.205080	UG	XLPE	300	1			
G10	RMU31001	RMU31001		10.533613	76.20502	UG	XLPE	300	1			
RMU31001	G11	Ground		10.533568	76.204931	UG	XLPE	300	1			
G11	G12	Ground		10.533644	76.202802	UG	XLPE	300	1			
G12	G13	Ground		10.533517	76.202757	UG	XLPE	300	1			
G13	G14	Ground		10.533178	76.202847	UG	XLPE	300	1			
G14	G15	Ground		10.532570	76.203092	UG	XLPE	300	1			
G15	G16	Ground		10.532547	76.203424	UG	XLPE	300	1			
G16	G17	Ground		10.531540	76.203547	UG	XLPE	300	1			
G17	RMU31002	RMU31002		10.531752	76.201493	UG	XLPE	300	1		5	5
RMU31002	ABL51002	ABL51002, ABI50914		10.531832	76.201586	UG	XLPE	300	1	2052.75	5	2057.75
ABL51002	P3	post		10.531583	76.201615	OH	Racoon			27.72		27.72
P3	G18	Ground		10.531674	76.201509	UG	XLPE	300	1			
G18	G19	Ground		10.531656	76.200733	UG	XLPE	300	1	27.72		27.72
G19	ABL51003	ABL51003		10.531623	76.200701	UG	XLPE	300	1	108.74	3	111.74
ABL51003	1	Omega genting palace	LT	10.531660	76.200679	UG	XLPE	240	1	4.75	30	34.75
ABL51003	P3-1	post		10.531660	76.200679	OH	Racoon			4.75		4.75
P3-1	P3-2	post		10.531755	76.20052	UG	XLPE	300	1	20.33		20.33
P3-2	2	CIDBI	LT	10.532144	76.200547	UG	XLPE	185	1	43.13	30	73.13
P3-1	P3-3	post		10.531666	76.200055	UG	XLPE	300	1	68.3		68.3
P3-3	3	Sreesankari	LT	10.532120	76.200172	UG	XLPE	240	1	51.82		51.82
P3	P4	post		10.531031	76.201756	OH	Racoon					
P4	P5	post		10.530401	76.201802	OH	Racoon			132.84		132.84
P5	RMU,37	Zudio	LT	10.530508	76.20192	UG	XLPE	185	1	17.52	7	24.52

From Map no	Map no	Pole/transformer/AB	Metering point	Latitude	Longitude	Cable	Cable type	Cable size (sq mm)	No of runs	Mapping distance (m)	Loose distance (m)	Total distance (m)
RMU Zudio	RMU TM tower	RMU		10.530858	76.202006	UG	XLPE	300				
RMU TM tower	TM Towers	T M Tower-Transformer		10.530853	76.202041	UG	XLPE	300		55	11	66
P5	P6	post		10.530007	76.201851	OH	Racoon			43.91		43.91
P6	RMU31003,34	MC TOWER	LT	10.529942	76.202264	UG	XLPE	300	1	45.77	4	49.77
P6	P7	post		10.529175	76.201897	OH	Racoon			92.28		92.28
P7	P7-1	post		10.529238	76.202011	OH	Racoon			14.29		14.29
P7-1	4	CA arcade	LT	10.529465	76.202074	UG	XLPE	240	1	26.04	10	36.04
P7	ABL51004	ABL51004		10.528715	76.20191	OH	Racoon			50.9		50.9
ABL51004	25	falkland	LT	10.528476	76.202179	UG	XLPE	300	1	50.53	10	60.53
P7	P8	post		10.528516	76.201906	OH	Racoon			22.02		22.02
P8	RMU31004	RMU		10.528547	76.20182	UG	XLPE	300	1			
RMU31004	27	chirang Apartment	LT	10.528627	76.201409	UG	XLPE	300	1	55.87	3	58.87
P8	P9	post		10.528181	76.20196	OH	Racoon					
P9	P10	post		10.527614	76.201998	OH	Racoon			100.38		100.38
P10	P10-1	post		10.527568	76.202117	OH	Racoon			13.98		13.98
P10-1	P10-2	post		10.527451	76.202367	UG	XLPE	300		30.96	6	36.96
P10-2	5	Coral Apartment	LT	10.527455	76.202467	UG	XLPE	185	1	10.95	8	18.95
P10	P11,6	Kerala Varma Bus stop	LT	10.527363	76.201997	OH	Racoon			27.76	3	30.76
P11	ABL51005	ABL51005		10.527208	76.201618	OH	Racoon					
ABL51005	P12	post		10.527178	76.201078	OH	Racoon					
P12	P13	post		10.527310	76.200046	OH	Racoon			217.99		217.99
P13	RMU31005	RMU31005		10.527402	76.20003	UG	XLPE	300	1	10.33	5	15.33
RMU31005	31	Palaise Grande App	LT	10.527763	76.199901	UG	XLPE	150	1	53.91	20	73.91
P13	7	Kerala Varma Hostel	LT	10.527503	76.198852	OH	Racoon			132.42		132.42
7	P14	post		10.527591	76.198841	OH	Racoon					
P14	P15	post		10.528925	76.199064	OH	Racoon					
P15	P16	post		10.529118	76.198656	OH	Racoon			214.61		214.61
P16	P16-1	post		10.529044	76.198722	OH	Racoon			11.52		11.52
P16-1	9	Temple Tower	LT	10.528974	76.198634	UG	XLPE	185	1	12.36	50	62.36
P16	P17	post		10.529191	76.198272	OH	Racoon					
P17	P18	post		10.529810	76.19877	OH	Racoon					
P18	P19	post		10.530158	76.198865	OH	Racoon			168.65		168.65
P19	10	Mahamaya App	LT	10.530146	76.198903	OH	Racoon			3.79		3.79
P19	ABL57007	ABL57007		10.530292	76.198939	OH	Racoon			16.06		16.06
ABL57007	11	Sreedurga App	LT	10.530169	76.197773	UG	XLPE	300	1	139.82	3	142.82
11	P20	post		10.530245	76.197214	OH	Racoon			63.56		63.56
P20	P20-1	post		10.530012	76.197097	UG	XLPE	300	1	35.54	3	38.54
P20-1	12	Blue Hills	LT	10.529952	76.197095	UG	XLPE	185	1	6.64	25	31.64
7	RMU31006, 30	Capital Green App	LT	10.527630	76.198371	UG	XLPE	300	1	54.49	50	104.49
RMU31006	RMU31007	RMU31007		10.527821	76.197864	UG	XLPE	300	1	59.38		59.38
RMU31007	32	Forus	LT	10.527645	76.197919	UG	XLPE	150	1	20.38	10	30.38

From Map no	Map no	Pole/transformer/AB	Metering point	Latitude	Longitude	Cable	Cable type	Cable size (sq mm)	No of runs	Mapping distance (m)	Loose distance (m)	Total distance (m)
7	G20	Ground		10.527928	76.19761	UG	XLPE	300	1			
G20	G21	Ground		10.529028	76.196268	UG	XLPE	300	1			
G21	G22	Ground		10.528845	76.196066	UG	XLPE	300	1			
G22	G23	Ground		10.528300	76.195804	UG	XLPE	300	1			
G23	ABL51009, 09	Kerala Varma	LT	10.528325	76.195724	UG	XLPE	300	1	441.91		441.91
ABL51009	G24	Ground		10.528316	76.195396	UG	XLPE	300	1			
G24	G25	Ground		10.528107	76.19512	UG	XLPE	300	1			
G25	G26	Ground		10.527212	76.194933	UG	XLPE	300	1			
G26	G27	Ground		10.525713	76.195284	UG	XLPE	300	1			
G27	G28	Ground		10.525824	76.195593	UG	XLPE	300	1			
G28	G29	Ground		10.525274	76.195974	UG	XLPE	300	1			
G29	G30	Ground		10.524536	76.196625	UG	XLPE	300	1			
G30	G31	Ground		10.523815	76.197061	UG	XLPE	300	1			
G31	22	Chungam	LT	10.522532	76.197060	UG	XLPE	300	1	803.93		803.93
22	P21	Post		10.521655	76.197131	OH	Racoon					
P21	35	Model Road	LT	10.521872	76.19881	OH	Racoon			285.88		285.88
35	G32	Ground		10.522016	76.198822	UG	XLPE	300	1			
G32	21	Central Park	LT	10.522294	76.198713	UG	XLPE	300	1	60.46	10	70.46
P11	P22	post		10.526862	76.202089	OH	Racoon					
P22	P23	post		10.526415	76.202184	OH	Racoon					
P23	P24	post		10.526066	76.202263	OH	Racoon					
P24	ABL51012	ABL51012		10.526051	76.202096	OH	Racoon			148.25		148.25
ABL51012	G33	Ground		10.526074	76.202315	UG	XLPE	300	1			
G33	G34	Ground		10.525730	76.202417	UG	XLPE	300	1			
G34	interlink	interlink post		10.526188	76.203761	UG	XLPE	300	1	225.69		225.69
ABL51012	ABL51015	ABL51015		10.525713	76.202148	OH	Racoon			37.82		37.82
ABL51015	P25	post		10.525741	76.201921	OH	Racoon					
P25	P26	post		10.525771	76.201614	OH	Racoon			58.81		58.81
P26	13	NP Tower	LT	10.525840	76.201408	OH	Racoon			23.81		23.81
P26	P27	post		10.525817	76.201075	OH	Racoon			59.22		59.22
P27	P27-1	post		10.525773	76.20105	OH	Racoon			5.58		5.58
P27-1	15	Capital Symphony	LT	10.525637	76.201109	UG	XLPE	300	1	16.37	20	36.37
P27	P28	post		10.525852	76.200729	OH	Racoon			38.07		38.07
P28	14	Bhadra App	LT	10.525886	76.200621	UG	XLPE	150	1	12.41	40	52.41
ABL51015	24	Bindhu Theatre	LT	10.524793	76.202208	UG	XLPE	300	1	101.97	10	111.97
24	RMU31008	RMU31008		10.524722	76.201983	UG	XLPE	300	1		10	10
RMU31008	33	Ansari Complex	LT	10.524792	76.201871	UG	XLPE	300	1	40.35		40.35
24	P29	post		10.524095	76.202237	UG	XLPE	300	1	77.27	10	87.27
P29	P29-1	post		10.524079	76.202011	UG	ABC			22.99		22.99
P29-1	16	Westfort Hospital	HT	10.524132	76.201775	UG	XLPE	300	1	28.02	5	33.02
P29	P30	post		10.523434	76.202214	OH	Racoon			73.16		73.16
P30	17	Haya Tower	LT	10.523369	76.201730	UG	XLPE	300	1	53.46		53.46
P30	P31	post		10.522859	76.20223	OH	Racoon					

From Map no	Map no	Pole/transformer/AB	Metering point	Latitude	Longitude	Cable	Cable type	Cable size (sq mm)	No of runs	Mapping distance (m)	Loose distance (m)	Total distance (m)
P31	ABL51017	ABL51017		10.522849	76.202314	OH	Racoon					
ABL51017	P32	post		10.522568	76.202344	OH	Racoon			104.14		104.14
P32	P32-1	post		10.522565	76.202482	OH	Racoon			15.11		15.11
P32-1	29	Jyothi Tower	LT	10.52272	76.202394	UG	XLPE	300	1	19.67	16	35.67
P32	P33	post		10.522264	76.202388	OH	Racoon					
P33	18	Westfort	LT	10.522170	76.202276	OH	Racoon			50.04		50.04
18	P34	post		10.521989	76.202110	OH	Racoon			27.04		27.04
P34	P34-1	post		10.521962	76.202223	OH	Racoon					
P34-1	ABL51018	ABL51018		10.521754	76.202236	OH	Racoon			35.78		35.78
ABL51018	G35	Ground		10.522013	76.202211	UG	XLPE	300	1			
G35	RMU31009	RMU31009		10.522180	76.201763	UG	XLPE	300	1		15	15
RMU31009	26	PV Arcade	LT	10.522630	76.2019	UG	XLPE	300	1	133.17	15	148.17
ABL51018	P34-2	post		10.521698	76.202191	OH	Racoon			7.91		7.91
P34-2	23	TipTop	HT	10.521642	76.202055	UG	XLPE	185	1	16.12	20	36.12
ABL51018	P39	post		10.520272	76.202306	OH	Racoon					
P39	P40	post		10.519783	76.20243	OH	Racoon					
P40	P41	post		10.519296	76.202584	OH	Racoon					
P41	P42	post		10.518333	76.202673	OH	Racoon					
P42	19	Calvary	LT	10.517971	76.202628	OH	Racoon			423.08		423.08
P34	interlink	Interlink		10.521759	76.201829	OH	Racoon			39.92		39.92
P34	P35	post		10.522017	76.201874	OH	Racoon					
P35	P36	post		10.522245	76.201772	OH	Racoon					
P36	P37	post		10.522194	76.201273	OH	Racoon					
P37	P38	post		10.522378	76.201250	OH	Racoon			122.36		122.36
P38	20	Westfort Tower	LT	10.522547	76.201335	UG	XLPE	185	1	27.75		27.75
P38	G36	Ground		10.522273	76.200862	UG	XLPE	300	1			
G36	RMU31010	RMU31010		10.522309	76.200842	UG	XLPE	300	1	46.1		46.1
RMU31010	28	Chowallur Tower	LT	10.522631	76.201078	UG	XLPE	300	1	44	20	64
RMU31010	G37	Ground		10.522122	76.200852	UG	XLPE	300	1			
G37	RMU31011	RMU31011		10.522047	76.200636	UG	XLPE	300	1			
RMU31011	36	Puthenpurakal Tower	LT	10.521984	76.200575	UG	XLPE	300	1	62.35	10	72.35

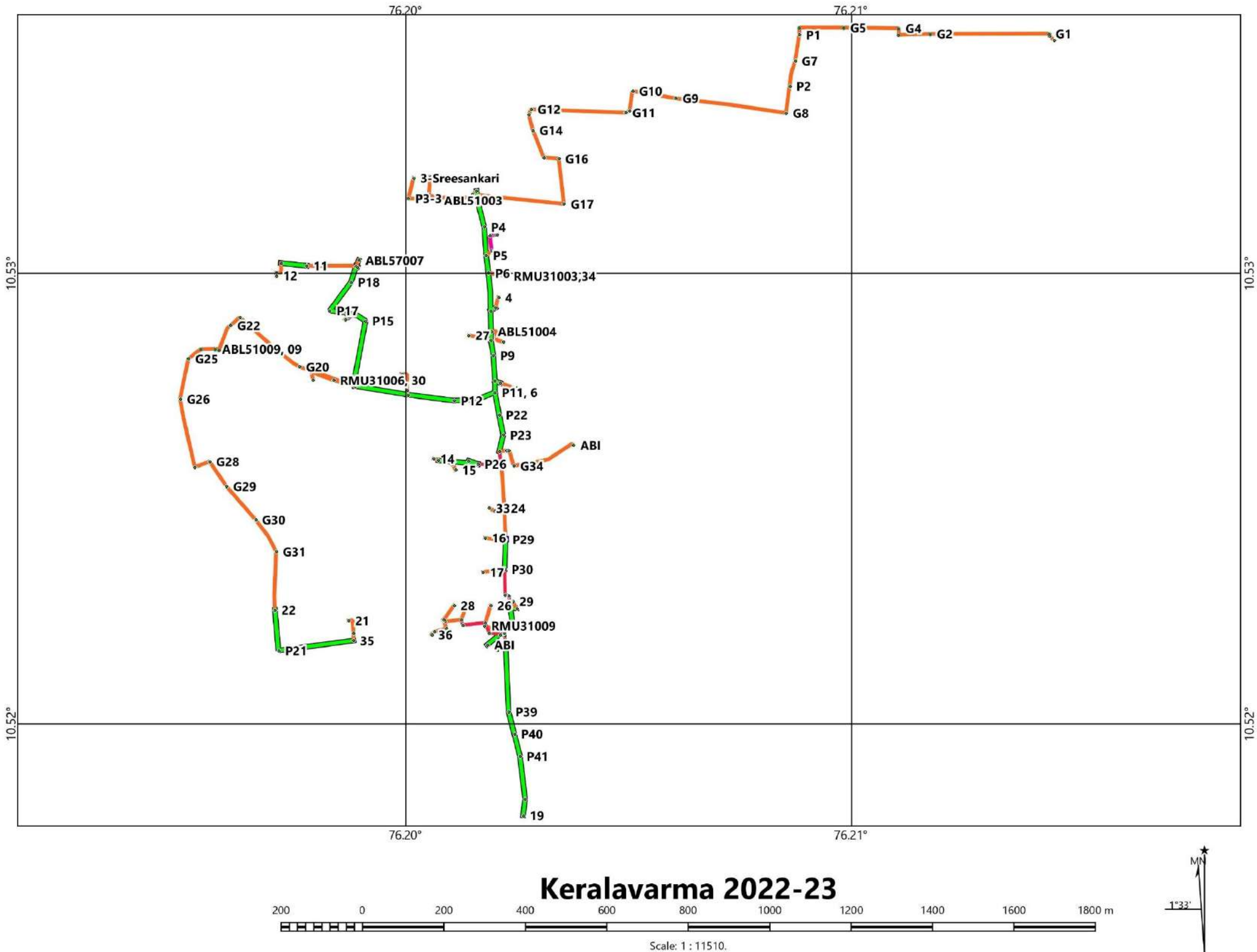

Keralavarma 2022-23

Figure 15: Keralavarma feeder

15 MISSION QUARTERS FEEDER

The following table shows the 11-kV line distance in the Mission quarters feeder

Table 29: HT line distance –Mission quarters feeder

From Map no	Map no	Pole/transformer/AB	Metering point	Latitude	Longitude	Cable	Cable type	Cable size (sq mm)	Mapping distance (m)	Loose distance (m)	Total distance (m)
	SS	Substation Feeder		10.517368	76.219734	UG	XLPE	300			
SS	P1	Post		10.517291	76.219765	UG	XLPE	300	9	10	19
P1	AB1	New Millenium Kuries		10.51727	76.219783	OH	Racoon		3		3
AB1	G1	Ground		10.51702	76.219535	UG	XLPE	300			0
G1	G2	Ground		10.517205	76.219359	UG	XLPE	300			0
G2	G3	Ground		10.517306	76.219262	UG	XLPE	300			0
G3	G4	Ground		10.517625	76.219598	UG	XLPE	300			0
G4	G5	Ground		10.517799	76.219449	UG	XLPE	300			0
G5	G6	Ground		10.51785	76.219466	UG	XLPE	300			0
G6	25	Millenium Kuries	LT	10.517831	76.219504	UG	XLPE	300	169	20	189
P1	G7	Ground		10.517559	76.21972	UG	XLPE	300	30		30
G7	G8	Ground		10.520088	76.222571	UG	XLPE	300	419		419
G8	RMU1	RMU30101		10.519931	76.222671	UG	XLPE	300	20		20
RMU1	G9	Ground		10.520251	76.222543	UG	XLPE	300			0
G9	G10	Ground		10.520454	76.222912	UG	XLPE	300	84		84
G10	RMU2	RMU30102		10.520485	76.222842	UG	XLPE	300	8		8
RMU2	27	Alice Legacy	LT	10.520596	76.222759	UG	XLPE	300	15	45	60
RMU2	G10	Ground		10.520454	76.222912	UG	XLPE	300	8		8
G10	G11	Ground		10.519577	76.221687	UG	XLPE	300			0
G11	RMU3	RMU30103		10.519438	76.221832	UG	XLPE	300			0
RMU2	11	Sky Tower	LT	10.519334	76.221878	UG	XLPE	300	200		200
RMU1	G12	Ground		10.519007	76.223046	UG	XLPE	300			0
G12	AB2	ABL50102		10.519669	76.225781	UG	XLPE	300	426		426

From Map no	Map no	Pole/transformer/AB	Metering point	Latitude	Longitude	Cable	Cable type	Cable size (sq mm)	Mapping distance (m)	Loose distance (m)	Total distance (m)
AB2	AB3,02(D)	ABI50103, Fathima Nagar, (ABFN)	LT	10.520148	76.225806	OH	Racoon		53		53
ABFN	AB4	ABI50104		10.521428	76.225855	OH	Racoon		142		142
AB2	P2	Post		10.519653	76.22553	OH	Racoon				0
P2	P3	Post		10.519569	76.225014	OH	Racoon		85		85
P3	P4	Post		10.519533	76.224732	OH	Racoon				0
P4	AB5	AB Navani Garden		10.519505	76.224719	OH	Racoon		35		35
AB5	1	Navani Heights(C)	LT	10.519414	76.224792	UG	XLPE	300	13	12	25
P3	AB6	AB Navani Garden		10.518907	76.225036	OH	Racoon		73		73
AB6	21 (c)	Navani Garden	LT	10.519082	76.224872	UG	XLPE	240	26	5	31
AB2	P5,AB7	Post,AB Jos		10.519408	76.225764	OH	Racoon		29		29
AB7	RMU4,31	RMU 30104, Jos Alukkas	HT	10.519162	76.225578	UG	XLPE	400	34	5	39
P5	P6	Post		10.518977	76.22575	OH	Racoon				0
P6	P7	Post		10.517783	76.225704	OH	Racoon		180		180
P7	AB8	AB-Muttichuokaran		10.517792	76.225084	OH	Racoon				0
AB8	3	Muttichuokaran (C/D)	LT	10.517813	76.225082	OH	Racoon		70		70
P7	AB9, AB10, 04	ABL50105, AB joy, Kallu Shapp (D) 250	LT	10.516503	76.225666	OH	Racoon		142		142
AB10	G13	Ground		10.51711	76.225689	UG	XLPE	300			0
G13	G14	Ground		10.517211	76.225683	UG	XLPE	300			0
G14	RMU5	RMU30105		10.517217	76.225746	UG	XLPE	300			0
RMU5	28	RMU30105, Joy Alukkas	HT	10.517157	76.225887	UG	XLPE	300	102	20	122
AB9	AB11	ABL50113,AB Kalyan		10.516411	76.225257	OH	Racoon		46		46
AB11	G15	Ground		10.516519	76.225209	UG	XLPE	300			0
G15	RMU7,30	RMU30107,Kalyan Hyper Market (c)	LT	10.517014	76.225236	UG	XLPE	300	68	8	76
AB11	P8	Post		10.516209	76.224508	OH	Racoon				0
P8	AB12	AB-Precious Home		10.51598	76.223846	OH	Racoon		162		162
AB12	G16	Ground		10.516075	76.223766	UG	XLPE	300			0

From Map no	Map no	Pole/transformer/AB	Metering point	Latitude	Longitude	Cable	Cable type	Cable size (sq mm)	Mapping distance (m)	Loose distance (m)	Total distance (m)
G16	G17	Ground		10.51751	76.22343	UG	XLPE	300			0
G17	G18	Ground		10.517008	76.222249	UG	XLPE	300			0
G18	RMU8	RMU30108		10.51696	76.222253	UG	XLPE	300			0
RMU8	32 (C)	Precious Home 315	LT	10.51685	76.22168	UG	XLPE	300	387	25	412
AB12	08 (D), P9	Post, Cemetery(D)	LT	10.515753	76.223291	OH	Racoon		66		66
P9	P10	Post		10.515613	76.22265	OH	Racoon				0
P10	P11	Post		10.515162	76.221407	OH	Racoon				0
P11	P12	Post		10.514403	76.221485	OH	Racoon		302		302
P12	P13	Post		10.513815	76.221737	OH	Racoon				0
P13	P14	Post		10.51349	76.221871	OH	Racoon		109		109
P14	AB13	AB-Pleasant hill		10.513453	76.221812	OH	Racoon		8		8
AB13	23 (c)	Pleasant hill	LT	10.51337	76.221527	UG	XLPE	150	33	10	43
P14	09,AB14	AB-Microwave, Microwave (D) 150kVA	LT	10.513288	76.221966	OH	Racoon		24		24
AB14	10(c)	BSNL Microwave (C)	HT	10.513163	76.222021	OH	Racoon		40		40
P12	P15	Post		10.514295	76.221027	OH	Racoon				0
P15	P16	Post		10.51408	76.220986	OH	Racoon				0
P16	P17	Post		10.51373	76.220738	OH	Racoon				0
P17	P18, AB15	Post , AB Chem		10.513664	76.220599	OH	Racoon		140		140
AB15	12 (c)	Chemmannam 160	LT	10.513213	76.220624	UG	XLPE	300	50	50	100
P18	P19	Post		10.513623	76.220136	OH	Racoon				0
P19	AB16	ABL50110		10.513571	76.219903	OH	Racoon				0
AB16	P20	Post		10.513913	76.219561	OH	Racoon		130		130
P20	AB17	ABL50111		10.513915	76.218859	OH	Racoon		78		78
AB17	AB18	AB ESAF		10.513917	76.218495	OH	Racoon		40		40
AB18	RMU10	RMU30110		10.513822	76.218574	UG	XLPE	300			0
RMU10	34 (C)	ESAF Jazz Tower (C)	LT	10.513847	76.218741	UG	XLPE	300	32	20	52
AB18	P21	Post		10.513939	76.217947	OH	Racoon		60		60

From Map no	Map no	Pole/transformer/AB	Metering point	Latitude	Longitude	Cable	Cable type	Cable size (sq mm)	Mapping distance (m)	Loose distance (m)	Total distance (m)
P21	14 (D), AB19	AB SIB,SIB (D), 500	LT	10.513903	76.21795	OH	Racoon		4		4
AB19	15 (C)	SIB2 (c) HT Meter	HT	10.513581	76.217949	UG	XLPE	300	36	5	41
P21	P22	Post		10.513951	76.21728	OH	Racoon				0
P22	P23	Post		10.513957	76.217162	OH	Racoon		86		86
P23	AB20	AB Vasan		10.514099	76.21716	OH	Racoon		16		16
AB20	16 (c)	Vasan Eye Care (HT)	HT	10.514294	76.217137	UG	XLPE	300	22	10	32
P23	P24	Post		10.51398	76.216753	OH	Racoon		45		45
P24	AB21	AB Das		10.514044	76.216747	OH	Racoon		7		7
AB 21	17 (c)	Das Continental HT	HT	10.514522	76.216668	UG	XLPE	300	54	20	74
P24	AB22	ABL 50112,RMU WP		10.513951	76.216266	OH	Racoon		54		54
AB22	G28	Ground		10.513984	76.216053	UG	XLPE	300			0
G28	G29	Ground		10.514279	76.215883	UG	XLPE	300			0
G29	RMU12	RMU30207		10.515646	76.215875	UG	XLPE	300	213		213
AB17	G19	Ground		10.513965	76.219473	UG	XLPE	300			0
G19	G20	Ground		10.514548	76.218934	UG	XLPE	300			0
G20	G21	Ground		10.515071	76.218169	UG	XLPE	300			0
G21	G22	Ground		10.515362	76.217812	UG	XLPE	300			0
G22	G23	Ground		10.515951	76.217601	UG	XLPE	300			0
G23	RMU11	RMU 30301		10.515947	76.217538	UG	XLPE	300	384		384
P20	P32	Post		10.514119	76.219365	OH	Racoon		31		31
P32	13(D)	St. Joseph's (D) 315	LT	10.514157	76.219435	OH	Racoon		9		9
P32	P31	Post		10.514586	76.218886	OH	Racoon				0
P31	P30	Post		10.514793	76.218647	OH	Racoon		108		108
P30	P26	Post		10.515147	76.218054	OH	Racoon		76		76
P26	P27	Post		10.515181	76.218181	OH	Racoon				0
P27	P28	Post		10.515448	76.21854	OH	Racoon				0
P28	P29	Post		10.515844	76.21918	OH	Racoon				0
P29	20 (c)	Retreat Apartment	LT	10.515835	76.219187	OH	Racoon		147		147
P26	P25	Post		10.515816	76.217635	OH	Racoon		91		91

From Map no	Map no	Pole/transformer/AB	Metering point	Latitude	Longitude	Cable	Cable type	Cable size (sq mm)	Mapping distance (m)	Loose distance (m)	Total distance (m)
P20	P33	Post		10.513334	76.220144	OH	Racoon				0
P33	P34	Post		10.512227	76.220738	OH	Racoon		230		230
P34	P35	Post (AB)		10.512239	76.220891	OH	ABC		17		17
P35	G24	Ground		10.512486	76.221466	UG	XLPE	300			0
G24	22 (c)	Skyline Infinity (Mundupalam)	LT	10.512246	76.221472	UG	XLPE	300	95	50	145
P34	P36	Post AB Asset)		10.511977	76.220815	OH	Racoon		29		29
P36	G24-1	Ground		10.51197	76.220906	UG	XLPE	300			0
G24-1	G25	Ground		10.511543	76.221088	UG	XLPE	300			0
G25	RMU9	RMU 30109		10.51158	76.221359	UG	XLPE	300	98		98
RMU9	26 (C)	Asset 400	LT	10.511676	76.221426	UG	XLPE	185	13	10	23
RMU9	G26	Ground		10.511534	76.221394	UG	XLPE	300			0
G26	G27	Ground		10.511865	76.223916	UG	XLPE	300			0
G27	AB23, 07	ABL 50108, Avenue road	LT	10.511926	76.22389	UG	XLPE	300	309		309
AB9	P37	Post		10.515065	76.226485	OH	Racoon		183		183
P37	P38	Post		10.51502	76.226537	OH	Racoon				0
P38	5	Xavy Thekkath 05 (L)	LT	10.515292	76.22687	OH	Racoon		55		55
P37	P39	Post		10.514399	76.226872	OH	Racoon		85		85
P39	P40	Post		10.51445	76.226902	OH	Racoon				0
P40	AB25	AB Aquatic		10.51472	76.22776	OH	Racoon		105	15	120
AB25	RMU6, 29	RMU30106, Aquatic 16	LT	10.514335	76.227915	UG	XLPE	300	46	2	48
AB25	P41	Post		10.514913	76.228523	OH	Racoon				0
P41	AB26	AB Federal		10.514856	76.228613	OH	Racoon		98		98
AB26	19(C)	Federal Residency 500	LT	10.514686	76.228834	UG	XLPE	300	31	30	61
P39	P42	Post		10.513846	76.227205	OH	Racoon				0
P42	P43	Post		10.513339	76.227349	OH	Racoon				0
P43	06 , P43-1	Post Swimming Pool	LT	10.512828	76.227428	OH	Racoon		187		187
P43-1	P44	Post		10.512534	76.227328	OH	Racoon				0

From Map no	Map no	Pole/transformer/AB	Metering point	Latitude	Longitude	Cable	Cable type	Cable size (sq mm)	Mapping distance (m)	Loose distance (m)	Total distance (m)
P44	P45	Post (to Avenue)		10.512158	76.227353	OH	Racoon		76		76
P45	P46	Post		10.512067	76.22779	OH	Racoon				0
P46	P47	Post		10.512074	76.228123	OH	Racoon				0
P47	P48	Post		10.512218	76.228852	OH	Racoon				0
P48	P49	Post		10.512434	76.229155	OH	Racoon		208		208
P49	P50	Post		10.512659	76.229431	OH	Racoon				0
P50	33 , P 50-1	Mulberry Department	LT	10.512922	76.229849	OH	Racoon		93		93
P50-1	P51	Post		10.513116	76.230183	OH	Racoon				0
P51	P52	AB SN Temp		10.513142	76.230226	OH	Racoon		48		48
P52	AB27	AB Mulberry		10.513095	76.230234	OH	Racoon		5		5
AB27	18	Mulberry	LT	10.512673	76.230443	UG	XLPE	150	52	40	92
P52	G30	Ground		10.513255	76.230704	UG	XLPE	300			0
G30	G31	Ground		10.513521	76.231284	UG	XLPE	300			0
G31	G32	Ground		10.51369	76.232611	UG	XLPE	300			0
G32	24 , P52-1	SN Temple 250	LT	10.513636	76.23268	UG	XLPE	300	280	10	290
P52-1	G33	Ground		10.513729	76.232789	UG	XLPE	300			0
G33	G34	Ground		10.51375	76.233389	UG	XLPE	300			0
G34	G35	Ground		10.513538	76.23439	UG	XLPE	300			0
G35	G36	Ground		10.513231	76.236005	UG	XLPE	300			0
G36	AB28	ABI 50107,		10.514016	76.236231	UG	XLPE	300	465		465
P45	P53	Post		10.512289	76.226992	OH	Racoon				0
P53	P54	Post		10.512218	76.225872	OH	Racoon				0
P54	P55	Post		10.512037	76.225043	OH	Racoon				0
P55	AB23	ABL 50108		10.511926	76.22389	OH	Racoon		383		383
AB23	RMU	RMU-Skyline Avenue		10.511965	76.224103	UG	XLPE	300		20	20
RMU	Skyline Avenue	Skyline Avenue Suites (Tr-1& 2)	LT	10.512826	76.224128	UG	XLPE	300	102		102

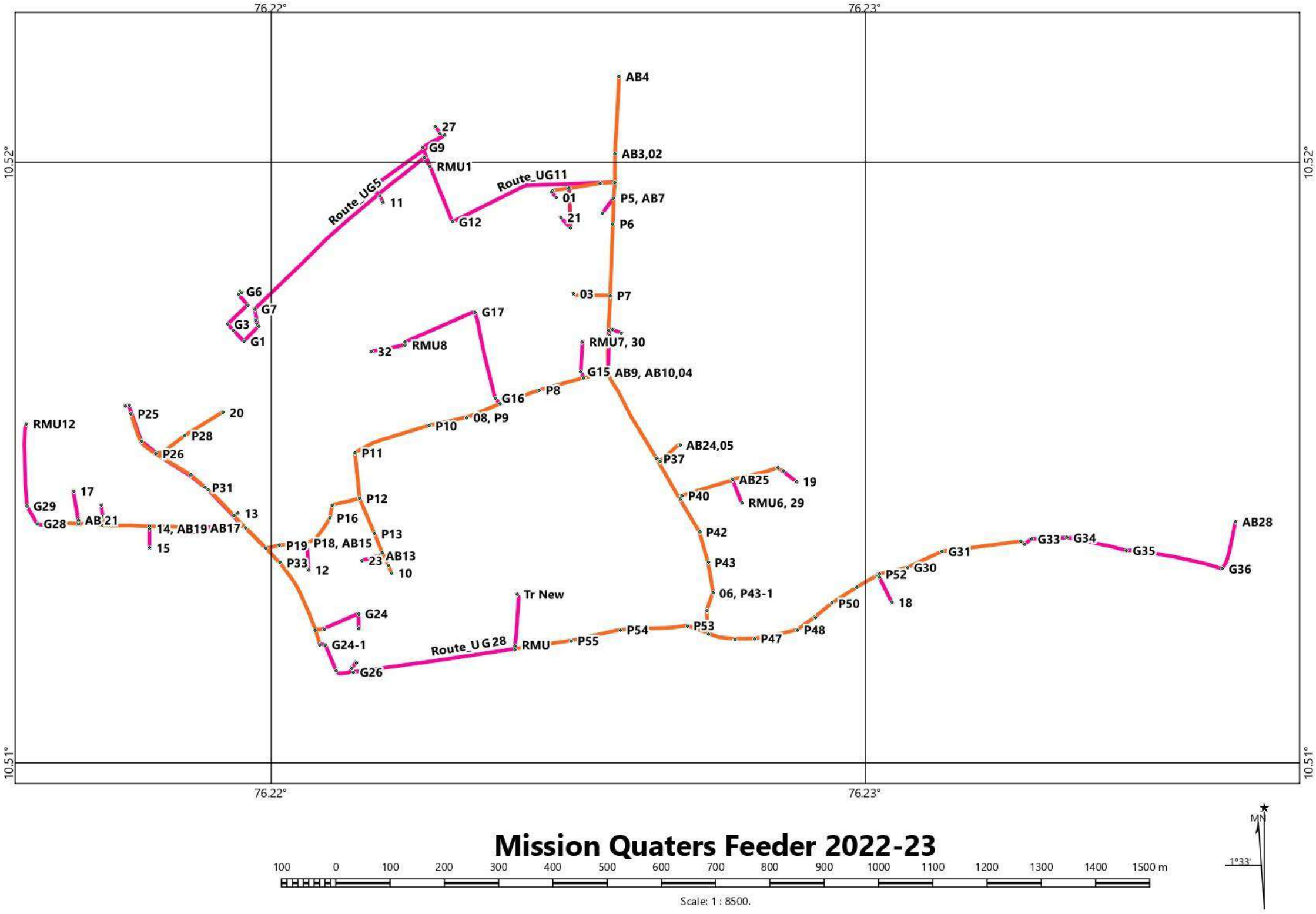

Figure 16: Mission quarters feeder

16 M O ROAD FEEDER

The following table shows the 11-kV line distance in the M O Road feeder

Table 30: HT line distance –M O Road feeder

From Map no	Map no	Pole/transformer/AB	Metering point	Latitude	Longitude	Cable	Cable type	Cable size (sq mm)	Total distance (m)
SS				10.535032	76.214680				
S-S	G1	Ground		10.534981	76.215007	UG	XLPE	300	36.21
G1	G2	Ground		10.531530	76.215136	UG	XLPE	300	
G2	P1	Post		10.531540	76.215200	UG	XLPE	300	5
P1	G3	Ground		10.529519	76.215011	UG	XLPE	300	
G3	P2	Post		10.529268	76.216105	UG	XLPE	300	
P2	G31	Ground		10.52907	76.216170	UG	XLPE	300	
G31	P3	Post		10.528782	76.216140	UG	XLPE	300	5
P3	G4	Ground		10.527338	76.215871	UG	XLPE	300	
G4	G32	Ground		10.526698	76.216763	UG	XLPE	300	
G32	G5	Ground		10.526698	76.216763	UG	XLPE	300	
G5	G33	Ground		10.52548	76.216930	UG	XLPE	300	
G5	P4	Post		10.524905	76.216880	UG	XLPE	300	1283.54
P4	49	Exhibition	LT	10.524908	76.216807	UG	XLPE	185	15
P4	G34	Ground		10.522970	76.216750	UG	XLPE	300	
G34	8P	ABI51203		10.522848	76.216595	UG	XLPE	300	5
8P	G6	Ground		10.522520	76.213958	UG	XLPE	300	
G6	AB1	ABL-51205		10.522069	76.213954	UG	XLPE	300	604.41
AB1	11	Pathans	LT	10.522245	76.214085	UG	XLPE	185	74.18
AB1	RMU1	RMU-31201		10.522181	76.213901	UG	XLPE	185	33.68
RMU1	53	Ragam Theatre	HT	10.522171	76.213797	UG	XLPE	185	25
RMU1	RMU2	RMU-31202		10.521768	76.213947	UG	XLPE	150	48.96
RMU2	50	Baby Paul	LT	10.521681	76.213874	UG	XLPE	150	12.51
AB1	P5	Post		10.521932	76.213976	OH	Racoon		15.34
P5	P5-1	Post		10.521924	76.213946	OH	Racoon		3.4
P5-1	17	Elite Hotel	HT	10.521741	76.213605	UG	XLPE	185	70
P5	P6	Post		10.521421	76.214022	OH	Racoon		56.75
P6	10	Manshire	HT	10.521364	76.214104	UG	XLPE	185	10.97
P6	P7	Post		10.521207	76.214034	OH	Racoon		23.71
P7	P7-1	Post		10.521220	76.213958	OH	Racoon		8.44
P7-1	16	Bharath Hotel	HT	10.521370	76.213755	UG	XLPE	150	27.73
RMU2	RMU3	RMU-31203		10.520982	76.214061	UG	XLPE	300	87.83
RMU3	54	White Palace	HT	10.520982	76.214061	UG	XLPE	300	0
P7	P8	Post		10.520820	76.214034	OH	Racoon		42.81
P8	P8-1	Post		10.520913	76.213386	OH	Racoon	300	71.67
P8-1	15	Lavish	LT	10.521101	76.213528	UG	XLPE	300	25.96
P8	AB2	ABL-51206		10.520540	76.214071	OH	Racoon		31.23
AB2	9	Store	LT	10.520540	76.214071	UG	XLPE	300	
AB2	AB3	Post		10.520014	76.214121	OH	Racoon		58.44
AB3	55	MK	HT	10.519291	76.214328	UG	XLPE	300	80
AB3	P9	Post		10.519953	76.214128	OH	Racoon		6.79
P9	P10	Post		10.520023	76.214316	OH	Racoon		21.99
P10	P10-1	Post		10.520083	76.214310	OH	Racoon		6.67
P10-1	Tr-1	Lamex(Not marked)	LT	10.52040	76.214309	OH	Racoon		35.29
P10	AB Fameel	AB Fameel		10.520237	76.214670	OH	Racoon		45.41
AB Fameel	RMU Fameel	RMU Fameel		10.520293	76.214645	UG	XLPE		
RMU Fameel	Tr- Fameel	Fameel	LT	10.520405	76.214686	UG	XLPE	300	19.95
P10	AB4	ABL-51208		10.520102	76.214511	OH	Racoon		23.06
AB4	RMU4,8	RMU-31204, Janardhanan Complex	LT	10.520135	76.214506	UG	XLPE	300	3.69
AB4	P11	Post		10.520317	76.215025	OH	Racoon		61.08
P11	AB5	ABL51208		10.520366	76.215044	OH	Racoon		5.81
AB5	1	Corporation Office	LT	10.520735	76.214975	OH	Racoon		41.51
P11	P12	Post		10.520404	76.215202	OH	Racoon		21.63
P12	2	BSNL CTD 1	LT	10.520765	76.215087	UG	XLPE	300	41.87
P12	3	BSNL CTD 2	LT	10.520765	76.215087	UG	XLPE	300	41.87
P12	G36	Ground		10.5203	76.21524	UG	XLPE	300	
G36	G37	Ground		10.52039	76.21554	UG	XLPE	300	
G37	G38	Ground		10.51995	76.21575	UG	XLPE	300	
G38	P12-1	Post		10.519929	76.215364	UG	XLPE	300	143.14
P12-1	4	BSNL Pattalam Exchange	HT	10.519805	76.215452	UG	XLPE	95	56.76
P12-1	5	BSNL Pattalam Exchange	HT	10.519805	76.215452	UG	XLPE	95	56.76
P12-1	6	BSNL Pattalam Exchange	HT	10.519805	76.215452	UG	XLPE	95	56.76
AB5	G7	Ground		10.520531	76.216110	UG	XLPE	300	
G7	G8	Ground		10.520710	76.216084	UG	XLPE	300	
G8	G9	Ground		10.520687	76.215796	UG	XLPE	300	
G9	RMU5	RMU-31205		10.521204	76.215696	UG	XLPE	300	
RMU5	52	Jai Hind Market	LT	10.521204	76.215696	UG	XLPE	300	227.96
RMU5	18	Jai Hind Solar	LT	10.521204	76.215696	UG	XLPE	300	227.96

From Map no	Map no	Pole/transformer/AB	Metering point	Latitude	Longitude	Cable	Cable type	Cable size (sq mm)	Total distance (m)
P9	P13	Post		10.519422	76.213076	OH	Racoon		129.27
P13	P13-1	Post		10.519320	76.213013	OH	Racoon		
P13-1	AB6	ABL-51209		10.519221	76.213037	OH	Racoon		24.48
AB6	13	CP Tower	LT	10.519241	76.213103	UG	XLPE	300	67.56
P13	P14	Post		10.519215	76.212470	OH	Racoon	300	70.17
P14	20	Jonsons	LT	10.519370	76.212283	UG	XLPE	300	76.7
AB6	G10	Ground		10.519044	76.213073	UG	XLPE	300	
G10	G11	Ground		10.518932	76.212894	UG	XLPE	300	
G11	G12	Ground		10.518410	76.212888	UG	XLPE		
G12	RMU6	RMU-31211		10.518353	76.212233	UG	XLPE		
RMU6	46	Mathrubhumi	HT	10.518091	76.212196	UG	XLPE	300	242.46
AB6	G13	Ground		10.519310	76.212945	UG	XLPE		
G13	G14	Ground		10.519103	76.212119	UG	XLPE		
G14	G15	Ground		10.519990	76.21217	UG	XLPE		
G15	P15	Ground		10.520063	76.211764	UG	XLPE		250.79
P15	21	Manappuram Hotel	HT	10.519746	76.211848	UG	XLPE	300	36.25
	22	Manappuram Hotel	LT	10.519746	76.211848	UG	XLPE		5
P15	P16	Post		10.520083	76.211627	OH	Racoon		15.16
P16	P16-1	Post		10.520030	76.211616	OH	Racoon		5.98
P16-1	29	Kuriland	LT	10.520030	76.211616	UG	XLPE	250	15
P16	G16	Ground		10.520075	76.211494	UG	XLPE		
G16	RMU7	RMU31208		10.520309	76.211478	UG	XLPE		
RMU7	45	Vattekkat Arcade	LT	10.520342	76.211602	UG	XLPE	300	79.58
P16	P17	Post		10.520121	76.211405	OH	Racoon		24.66
P17	14	Jose Alukas	HT	10.520400	76.211418	UG	XLPE	300	50.89
P17	31	New Manshire	HT	10.519552	76.211518	UG	XLPE	300	75.14
P17	AB7	ABL-51213		10.520064	76.210882	OH	Racoon		57.59
AB7	G19	Ground		10.518936	76.210834	UG	XLPE		
G19	RMU8	RMU-31209		10.518793	76.210390	UG	XLPE	300	
RMU8	43	Sapphire Hotel	HT	10.518743	76.210353	UG	XLPE	300	212.84
RMU8	RMU9	RMU-31210		10.518743	76.210353	UG	XLPE	185	50
RMU9	47	TCR Fashion	HT	10.518382	76.210324	UG	XLPE	185	
AB7	P18	Post		10.520059	76.210762	OH	Racoon		13.15
P18	G17	Ground		10.520064	76.210882	UG	XLPE	300	
G17	G18	Ground		10.519531	76.210882	UG	XLPE	300	
G18	26	Alukkas Seafort	HT	10.519455	76.210769	UG	XLPE	300	87.06
AB7	P19	Post		10.519656	76.210917	OH	Racoon		45.29
P19	25	Ammus Regency	HT	10.519614	76.210981	UG	XLPE	185	30
P18	P20	Post		10.519997	76.210429	OH	Racoon		37.09
P20	P20-1	Post		10.520283	76.210387	OH	Racoon		31.97
P20-1	23	Lafame(Sayooja Apartment)	LT	10.520283	76.210387	OH	Racoon		
P20-1	P20-2	Post		10.520300	76.210309	OH	Racoon		8.74
P20-2	24	Omega Paradise	LT	10.520341	76.210147	UG	XLPE	185	30
P20	AB8	ABL-51214		10.519991	76.210033	OH	Racoon		43.35
AB8	30	Kovilakam	LT	10.519842	76.210023	UG	XLPE	240	37
AB8	P21	Post		10.519938	76.209686	OH	Racoon		38.43
P21	P21-1	Post		10.520465	76.209721	OH	Racoon		58.42
P21-1	G19	Ground		10.520548	76.209546	UG	XLPE	300	
G19	27	Sagara Apartment	LT	10.520896	76.209356	UG	XLPE	300	64.99
P21	P22	Post		10.519553	76.209716	OH	Racoon		
P22	51	Pearl Dept.	LT	10.519553	76.209716	OH	Racoon		42.71
P22	P22-1	Post		10.519583	76.209668	OH	Racoon		6.21
P22-1	28	Pearl Regency	HT	10.519613	76.209390	UG	XLPE	240	30.61
P15	G20	Ground		10.520081	76.211476	UG	XLPE	300	
G20	G21	Ground		10.521663	76.211608	UG	XLPE		
G21	G22	Ground		10.521725	76.212136	UG	XLPE		
G22	G23	Ground		10.522263	76.212179	UG	XLPE		324.72
G23	G24	Ground		10.522255	76.212579	UG	XLPE		
G24	AB9, 32	ABL-51212, Kuruppam Road 1	LT	10.522392	76.212581	UG	XLPE	300	43.97
G24	AB9, 33	ABL-51212, Kuruppam Road 2	LT	10.522392	76.212581	UG	XLPE	300	43.97
AB9	7	Jaya Palace	LT	10.522434	76.212576	UG	XLPE	240	15
AB9	G24	Ground		10.522255	76.212579	UG	XLPE	300	
G24	G23	Ground		10.522263	76.212179	UG	XLPE		
G23	34	Enark Apartment	LT	10.522138	76.211791	UG	XLPE	300	53.9
AB9	P23	Post		10.522271	76.212578	OH	Racoon		9.15
P23	AB10	ABL-50503		10.522269	76.212192	OH	Racoon		42.25
AB10	G25	Ground		10.522273	76.211561	UG	XLPE	300	
G25	19	Luciya Palace	HT	10.522009	76.211332	UG	XLPE		107.55
AB10	P24	Post		10.522311	76.212319	OH	Racoon		14.66
P24	35	Nest Shopping	LT	10.522466	76.212239	UG	XLPE	250	25
P23	G26	Ground		10.522188	76.212754	UG	XLPE		
G26	G27	Ground		10.521456	76.212532	UG	XLPE		
G27	P25	Post		10.521469	76.212468	UG	XLPE		117.87
P25	36	Trade Centre1	HT	10.521388	76.212244	UG	XLPE	240	27

From Map no	Map no	Pole/transformer/AB	Metering point	Latitude	Longitude	Cable	Cable type	Cable size (sq mm)	Total distance (m)
P25	37	Trade Centre 2	LT	10.521388	76.212244	UG	XLPE	240	27
P25	G27	Ground		10.521456	76.212532	UG	XLPE	300	
G27	G28	Ground		10.520672	76.212301	UG	XLPE		
G28	P26	Post		10.520660	76.212381	UG	XLPE		98.89
P26	38	Grand Park Hotel1	HT	10.520526	76.212598	UG	XLPE	150	30
P26	39	Grand Park Hotel 2	HT	10.520526	76.212598	UG	XLPE	150	30
P26	P27	Post		10.520557	76.212276	OH	Racoon		16.18
P27	P28	Post		10.520296	76.212243	OH	Racoon		29.09
P28	RMU10	RMU-31207		10.520243	76.212347	UG	XLPE	300	19.2
RMU10	42	Hotel Garuda	HT	10.520216	76.212513	UG	XLPE	240	29.41
P28	P29	Post		10.519984	76.212160	OH	Racoon		34.6
P29	RMU11, 44	RMU31206, TSR Dist. Cop. Bank	HT	10.519818	76.212369	UG	XLPE	300	30
P29	P30	Post		10.518497	76.211951	OH	Racoon		168.32
P27	P31	Post		10.521545	76.212556	OH	Racoon		113.5
P31	RMU12, 6	Not Marked, Fridge Hosue	HT	10.521305	76.212595	UG	XLPE	300	30
P31	P32	Post		10.522188	76.212749	OH	Racoon		74.19
P32	P33	Post		10.522245	76.212883	ABC			25.97
P33	40	Pooram Residency1	HT	10.522222	76.213272	UG	XLPE	240	30
P33	41	Pooram Residency 2	LT	10.522222	76.213272	UG	XLPE	240	30
AB1	G29	Ground		10.522499	76.213876	UG	XLPE	185	
G29	G30	Ground		10.522614	76.213349	UG	XLPE	185	
G30	12	Pathayyapura	LT	10.522421	76.21327	UG	XLPE	185	141.43

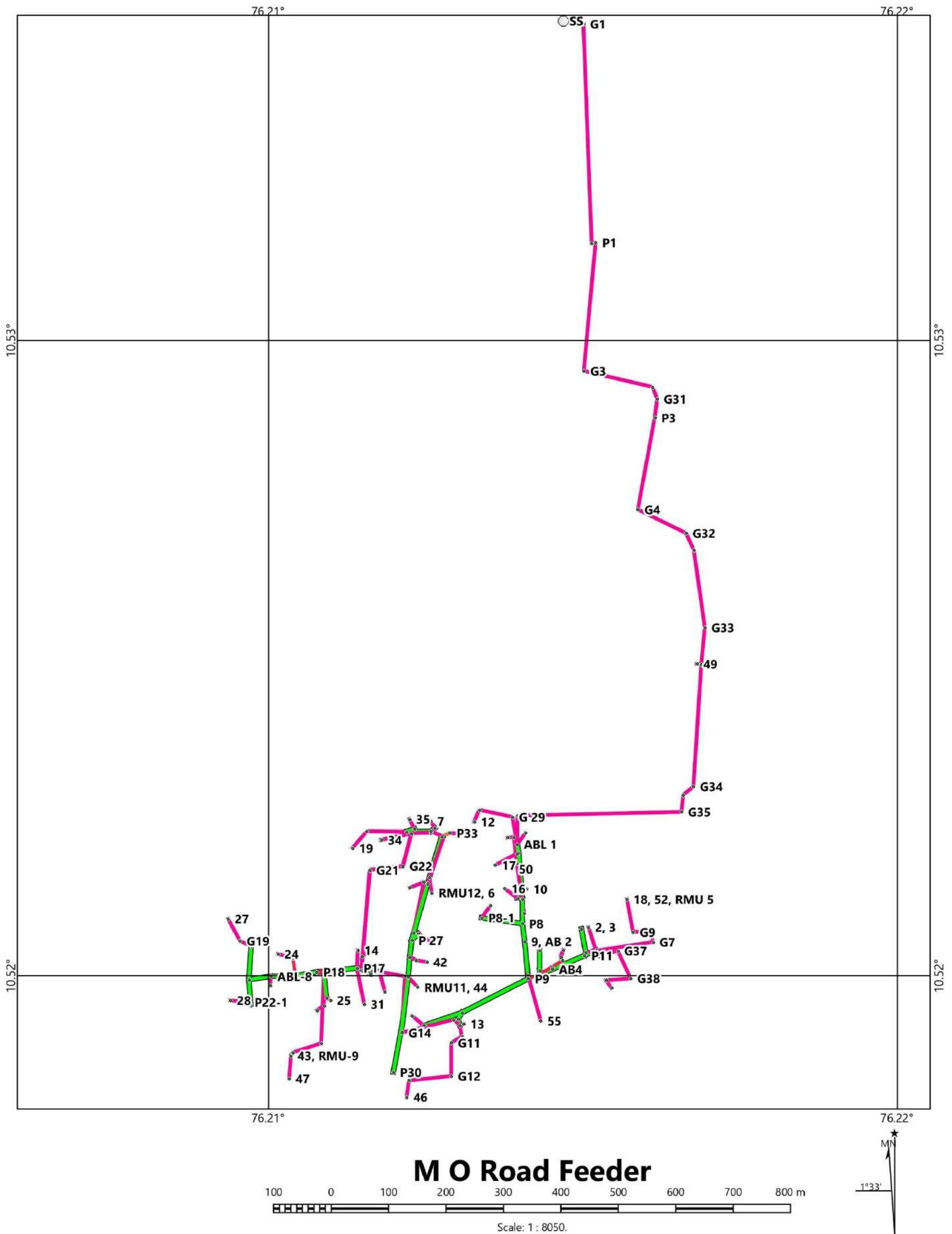

17 PARAVATTANI FEEDER

The following table shows the 11-kV line distance in the Paravattani feeder

Table 31: HT line distance –Paravattani Feeder

Map no	Map no	Pole/transformer/ AB	Latitude	Longitude	Cable	Cable type	Cable size (sq mm)	Mapping distance (m)	Loose distance (m)	Total distance (m)
	S-S	Substation feeder	10.517316	76.219691						
S-S-2	2P	Post	10.517261	76.219740	UG	XLPE	300			-
2P	G1	Ground	10.517380	76.219910	UG	XLPE	300			-
G1	G2	Ground	10.517550	76.219750	UG	XLPE	300			-
G2	2P1	Post	10.520059	76.222618	UG	XLPE	300			-
2P1	G3	Ground	10.518950	76.223060	UG	XLPE	300			-
G3	G4	Ground	10.519730	76.225720	UG	XLPE	300			-
G4	AB1	ABL-50402	10.519805	76.225852	UG	XLPE	300	931	30	961
AB1	AB2	ABI-50103	10.520153	76.225758	OH	Racoon		40		40
AB1	P1	Post	10.519774	76.226122	OH	Racoon		30		30
P1	P1-1	AB-Jose Pottukaran	10.519736	76.226126	OH	Racoon		4		4
P1-1	11	Jose pottokoran	10.519489	76.226056	UG	XLPE	300	35	5	40
P1-1	Life Scan	Lifescan (315 kVA)	10.519645	76.226092	UG	XLPE	300	13	21	34
P1	P2	Post	10.519691	76.226866	OH	Racoon		82		82
P2	ABn, Fathima	ABL New, Fathima (250 kVA)	10.519206	76.226741	OH	Racoon		55		55
Abn	P2-1	AB-Manjali	10.519227	76.226835	OH	Racoon		9		9
P2-1	9	Manjali Enclave	10.518991	76.226882	UG	XLPE	185	35	5	40
P2	P3	Post	10.519375	76.228599	OH	Racoon		193		193
P3	P3-1	AB YAS	10.519321	76.228596	OH	Racoon		6		6
P3-1	1	YAS Residency/TT Complex	10.518962	76.228605	UG	XLPE	300	40	11	51
P3	P4	Post	10.519059	76.230379	OH	Racoon				198
P4	P4-1	AB Cedar	10.518746	76.230430	ABC	XLPE				34
P4-1	12	Cedar Apartment	10.518602	76.230057	UG	XLPE	300	49	5	54
P4	AB3	ABL-50403	10.518796	76.231426	OH	Racoon		118		118
AB3	2	Andrews	10.518745	76.231455	OH	Racoon		6		6
2	P6	Post	10.517758	76.231749	OH	Racoon		114		114
P6	AB9	ABL-50410	10.517628	76.231785	OH	Racoon		15		15
AB9	G5	Ground	10.516416	76.232005	UG	XLPE	300	136		136
G5	G6	Ground	10.516348	76.231082	UG	XLPE	300	104		104
G6	P7	AB Fortune	10.516424	76.231044	UG	XLPE	300	9		9
P7	10	In Land/Fortune Apartment	10.516509	76.230933	UG	XLPE	300	15		15
P7	G7	Ground	10.517747	76.230668	UG	XLPE	300	153		152
G7	RMU10	RMU-30410	10.517859	76.230545	UG	XLPE	300	17		17
RMU10	23	CIDBI Apartment	10.518134	76.230545	UG	XLPE	185	38	32	70
AB9	P7-1	Post	10.516998	76.232545	OH	Racoon		109		109
P7-1	P8	Post	10.516937	76.232844	OH	Racoon		33		33
P8	P8-1	AB Pentark	10.516403	76.232943	UG	XLPE	300	73	10	83
P8-1	25	Pentark East Park	10.516314	76.233337	UG	XLPE	150	49	12	61
P8	P9	Post	10.516856	76.233670	OH	Racoon	300	91		91
P9	P10	Post	10.516966	76.233621	OH	Racoon	300	13		13
P10	P10-1	AB Wheel	10.517526	76.233629	OH	Racoon		60		60
P10-1	8	Wheels Apartment	10.517627	76.233602	UG	XLPE	150	22	5	27
AB3	RMU1, 24	RMU30401, SNA	10.51873	76.23211	UG	XLPE	300	80	70	150
AB3	G8	Ground	10.518810	76.232177	UG	XLPE	300	82		82
G8	AB4	ABL-50404	10.520351	76.232312	UG	XLPE	300	173		173

Map no	Map no	Pole/transformer/ AB	Latitude	Longitude	Cable	Cable type	Cable size (sq mm)	Mapping distance (m)	Loose distance (m)	Total distance (m)
AB4	P5, 3	Post, Unnimossa	10.5204394	76.2323586	OH	Racoon	300	11		11
AB4	RMU2, 14	RMU30402, Sundale Apartment	10.5200728	76.2326466	UG	XLPE	300	58	10	68
RMU2	RMU3, 27	RMU30403, Able Tower	10.5208145	76.2315234	UG	XLPE	300	158		158
P5	16	Homeo	10.5196024	76.2335907	OH	Racoon				163
16	P5-1	Post	10.519423	76.234441	OH	Racoon	300			95
P5-1	P5-2	Post	10.519573	76.235103	OH	Racoon	300	75		75
P5-2	AB6	ABL-50411, ABL50412	10.5197139	76.2353868	OH	Racoon	300	35		35
AB6	5	Paravattani Park	10.520350	76.2362215	OH	Racoon	300	115		115
5	P11	Post	10.520809	76.236897	OH	Racoon	300	90		90
P11	RMU7	RMU30407	10.520510	76.2367836	UG	XLPE	300	46		46
RMU7	15	GEM Hospital(315 kVA)	10.5204513	76.2369888	UG	XLPE	300	30	25	55
P11	P12	Post	10.521832	76.2387516	OH	Racoon	300	232		232
P12	P13	Post	10.5219379	76.2390057	UG	XLPE	300	30	20	50
P13	6	Paravattani	10.5226186	76.240308	OH	Racoon	300	161		161
6	P14	Post	10.5229869	76.2414791	OH	Racoon	300	135		135
P14	P14-1	Post	10.521050	76.2417765	OH	Racoon		217		217
P14-1	18	Store	10.520876	76.240876	UG	XLPE	300	100	10	110
AB6	17	Double Horse	10.518408	76.236069	OH	Racoon		163		163
17	P15	Post	10.517034	76.236371	OH	Racoon		157		157
P15	P16	Post, AB-Asset	10.516418	76.236443	OH	Racoon		69		69
P16	RMU8	RMU30408	10.5164168	76.2366303	UG	XLPE	300	21		21
RMU8	26	Asset Precious	10.5160357	76.2365593	UG	XLPE	300	43		43
P16	AB7	ABL-50413	10.514729	76.236411	OH	Racoon		187		187
AB7	13	Deepak Tom(Jewelima Diamonds)	10.515494	76.235448	UG	XLPE	300	166	20	166
13	RMU9, 22	RMU30409, Sisters	10.515087	76.235637	UG	XLPE	300	61		61
AB7	AB8, 7	Kankapadan, ABI-50107	10.514019	76.236277	OH	Racoon		80		80
P5	AB5	ABL50405	10.520894	76.232395	UG	XLPE	300		20	50
AB5	G9	Ground	10.521738	76.232354	UG	XLPE	300			93
G9	G10	Ground	10.521817	76.233048	UG	XLPE	300	77		77
G10	P17	Post	10.522846	76.233721	UG	XLPE	300	137	10	147
P17	G12	Ground	10.526317	76.23423	UG	XLPE	300	397		397
G12	AB10, 4	ABL-50407/ABL-50408, Ottu company	10.526291	76.234257	UG	XLPE	300	4	20	24
AB10	G12	Ground	10.526317	76.23423	UG	XLPE	300	4		4
G12	P18	Post	10.527272	76.234004	UG	XLPE	300	109	20	109
P18	G13	Ground	10.5272238	76.2330394	UG	XLPE	300	107		107
G13	G14	Ground	10.527921	76.232895	UG	XLPE	300	79		79
G14	G15	Ground	10.527969	76.232653	UG	XLPE	300	27		27
G15	G16	Ground	10.528381	76.232501	UG	XLPE	300	49		49
G16	AB11	ABI-50409	10.528336	76.231755	UG	XLPE	300	82	10	92
AB10	G12	Ground	10.526317	76.23423	UG	XLPE	300	4		4
G12	G17	Ground	10.525700	76.234197	UG	XLPE	300	74		74
G17	RMU2, 19	RMU-30404, Pookuzhypadam	10.525326	76.233055	UG	XLPE	300	139	5	144
RMU2	G18	Ground	10.524669	76.229320	UG	XLPE	300	415		415
G18	G19	Ground	10.5241494	76.2295816	UG	XLPE	300	82		82
G19	RMU3	RMU-30405	10.524144	76.229747	UG	XLPE	300	22		22
RMU3	20	Mystic Rose(Mulberry)	10.524170	76.229983	UG	XLPE	150	36	10	46
RMU3	G20	Ground	10.524173	76.229377	UG	XLPE	300			
G20	RMU4	RMU-30406	10.5233967	76.229539	UG	XLPE	300			128
RMU4	21	Nirmalamatha	10.5233762	76.2294951	UG	XLPE	150	134	5	139

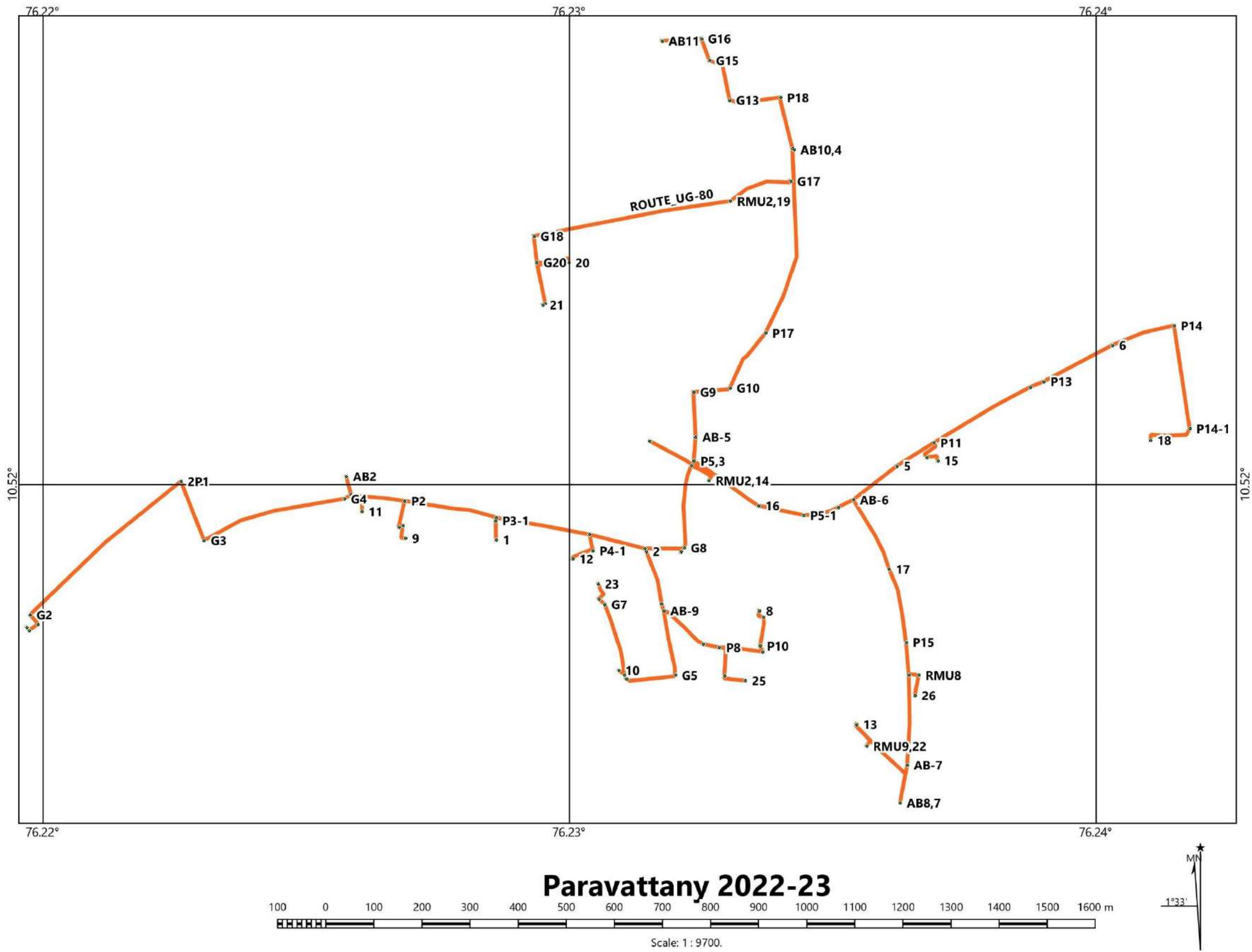

Paravattany 2022-23

Figure 18: Paravattani feeder

18 POONKUNAM FEEDER

The following table shows the 11-kV line distance in the Poonkunam feeder

Table 32: HT line distance – Poonkunam Feeder

From Map no	Map no	Pole/transformer/ AB	Latitude	Longitude	Cable	Cable type	Cable size (sq mm)	Mapping distance (m)	Loose distance (m)	Total distance (m)
	ss	Substation Feeder	10.535157	76.214636						
SS	2P	Post	10.535272	76.214564	UG	XLPE	300			
2P	AB1	ABL50902, ABI50903	10.535345	76.209502	UG	XLPE	300			
AB1	AB2	ABI50904	10.535358	76.208746	UG	XLPE	300	678	5	683
AB2	G1	Ground	10.535476	76.208639	UG	XLPE	300			
G1	01, AB4	Omega Swami Saranam, ABL 50905	10.536126	76.208427	UG	XLPE	300	93	5	98
ABL4	RMU1, 28	Sarong Homes Apartment, RMU30901	10.536473	76.208404	UG	XLPE	300	98		98
RMU1	G2	Ground	10.536492	76.208432	UG	XLPE	300	4		4
G2	G3	Ground	10.536125	76.208450	UG	XLPE	300	41		41
G3	RMU2	RMU30902	10.536110	76.207299	UG	XLPE	300	130		130
RMU2	31	Pallissery Apartment	10.535922	76.207287	UG	XLPE	300	21		21
AB2	AB3	ABI50906	10.535331	76.208117	OH	Racoon		69		69
AB3	P1	Post	10.535337	76.207504	OH	Racoon		67		67
P1	2	Classic Park	10.535526	76.207404	OH	Racoon		25		25
P1	P2	Post	10.535304	76.206774	OH	Racoon		80		80
P2	P2-1	AB-Falkland Square	10.535254	76.206772	OH	Racoon		6		6
P2-1	25	Falkland Square	10.535232	76.206838	UG	XLPE	300	33		33
P2	P3	Post	10.536618	76.206981	OH	Racoon		147		147
P3	P3-1	AB-Inland	10.536831	76.207147	UG	XLPE	300	35		35
P3-1	21	Westend Krishna Apartment	10.536820	76.207213	UG	XLPE	300	60		60
P2	P4	Post	10.535243	76.206020	OH	Racoon		83		83
P4	P4-1	AB-Capital	10.535454	76.205994	OH	Racoon		24		24
P4-1	3	Capital Harmony	10.535525	76.206123	UG	XLPE	185	51		51
P4	P5, ABL5	Post,ABL-50907	10.535254	76.205839	OH	Racoon		20		20
P5	P5-1	AB-Omega	10.535439	76.205829	OH	Racoon		20		20
P5-1	4	Omega Crown	10.535629	76.205702	UG	XLPE	150	75		75
P5	5	Ramadevi-1	10.535208	76.205801	UG	XLPE	300	32		32
P5	RMU3	RMU-30903	10.535207	76.205801	UG	XLPE	300	27		27
RMU3	29	Aricaria Jyothi Nest Apartment	10.535158	76.205617	UG	XLPE	300	82		82
P5	P6	Post	10.535264	76.204846	OH	Racoon		109		109
P6	P7	AB-Ephta	10.535643	76.204863	OH	Racoon		44		44
P7	RMU4	RMU-30904	10.535526	76.204854	UG	XLPE	300	51		51
RMU4	32	Ephatha	10.5356289	76.204669	UG	XLPE	185	73		73
P7	6	Lakshmi Apartment	10.535965	76.204842	OH	Racoon		39		39
P6	P8	Post	10.535254	76.204113	OH	Racoon		80		80
P8	P8-1	AB-Kalyan	10.535333	76.204113	OH	Racoon		9		9
P8-1	7	Kalyan	10.535955	76.204283	UG	XLPE	300	91		91
P8	P9	Post	10.535229	76.203339	OH	Racoon		85		85
P9	8	Sitaram Mill	10.535476	76.203305	OH	Racoon		28		28
8	AB6	ABL-50908	10.535485	76.203321	OH	Racoon		2		2
AB6	9	Dhanalaxmi Office	10.535641	76.202980	UG	XLPE	300	54		54
AB6	RMU5	RMU-30905	10.537322	76.203749	UG	XLPE	300	244		244
RMU5	27	Gulmohar Apartment	10.537170	76.203781	UG	XLPE	150	17		17
RMU5	RMU6	RMU-30906	10.538101	76.203319	UG	XLPE	300	134		134

From Map no	Map no	Pole/transformer/ AB	Latitude	Longitude	Cable	Cable type	Cable size (sq mm)	Mapping distance (m)	Loose distance (m)	Total distance (m)
RMU6	30	Ground Water	10.538101	76.203319	UG	XLPE	300		10	10
RMU6	G4	Ground	10.538531	76.203326	UG	XLPE	300			
G4	G7	Ground	10.53903	76.20271	UG	XLPE	300			
G7	AB7	ABL-50912	10.538397	76.202109	UG	XLPE	300	314	10	324
AB7	RMU7	RMU-30907	10.538407	76.202027	UG	XLPE	300	9	5	14
RMU7	33	SreeRam Temple	10.538407	76.202027	UG	XLPE	300		10	10
RMU7	RMU8	RMU-30908	10.538041	76.202094	UG	XLPE	300	49		49
RMU8	34	Top Tulip	10.537873	76.202005	UG	XLPE	300	29		29
AB7	12	Ram Nikethan	10.538360	76.202494	UG	XLPE	300	60		60
P9	P10	Post	10.535232	76.202978	OH	Racoon				-
P10	AB8	ABL-50909	10.535048	76.202957	OH	Racoon		60		60
AB8	P10-1	AB-Sree Sailam	10.534688	76.203694	OH	Racoon		90		90
P10-1	10	Sree Sailam	10.534067	76.203037	UG	XLPE	300	130		130
AB8	P11	Post	10.535057	76.201372	UG	XLPE	300	183	10	193
P11	AB9	ABL-50913	10.535326	76.201445	OH	Racoon		31		31
AB9	AB10	ABL-50190	10.535455	76.201445	OH	Racoon		14		14
AB10	RMU10	RMU-30910	10.535455	76.201382	UG	XLPE	300	7		7
RMU10	37	Sayooj Haridas	10.535620	76.201270	UG	XLPE	185	33		33
AB10	P11-1	AB-Neelambari	10.536391	76.201307	OH	Racoon		105		105
P11-1	22	Neelambari Apartment	10.536426	76.201412	UG	XLPE	300	12		12
P11-1	P11-2	AB-Capital Horizon	10.536946	76.201169	OH	Racoon		63		63
P11-2	11	Capital Horizon	10.537095	76.201838	UG	XLPE	300	97		97
P11-2	P12	Post	10.537055	76.201185	OH	Racoon		12		12
P12	26	Ramachandra Apartment	10.537054	76.201158	OH	Racoon		3		3
P12	P13	Post	10.538293	76.201026	OH	Racoon		126		126
P13	RMU13	RMU-Hanuman Statue	10.538644	76.200985	UG	XLPE	300	39		39
RMU13	13	Pushpagiri	10.538662	76.201049	UG	XLPE	300	7		7
RMU13	14	Vijay Sai	10.537736	76.200734	UG	XLPE	150	104		104
RMU13	G9	Ground	10.539111	76.201148	UG	XLPE	300			
G9	G10	Ground	10.539146	76.201389	UG	XLPE	300			
G10	G11	Ground	10.539852	76.201437	UG	XLPE	300			
G11	G12	Ground	10.540326	76.201436	UG	XLPE	300			
G12	RMU9	RMU30909	10.540342	76.201309	UG	XLPE	300	227		227
RMU9	35	Krishna Saketh	10.540339	76.201276	UG	XLPE	300	4	10	14
AB9	P14	Post	10.535622	76.200737	OH	Racoon				-
P14	P15	Post	10.536081	76.200141	OH	Racoon		167		167
P15	P15-1	AB-Capital Garden	10.536045	76.200017	OH	Racoon		19		19
P15-1	15	Capital Garden	10.535728	76.199796	UG	XLPE	150	43	7	50
P15	P15-2	AB-Asset	10.536252	76.199975	OH	Racoon		27		27
P15-2	23	Asset Mid Town Poonkunnam	10.535524	76.199172	UG	XLPE	300	138	13	151
P15-2	RMU11	RMU-30911	10.536403	76.199537	UG	XLPE	300			
RMU11	36	SAFA Tower	10.536403	76.199537	UG	XLPE	300	63	16	79
P11	P11-3	AB-Dhanalaxmi	10.535035	76.201303	OH	Racoon		7		7
P11-3	RMU12	RMU-30912	10.534944	76.201292	UG	XLPE	300	11		11
RMU12	38	Dhanalakshmi Bank	10.534944	76.201292	UG	XLPE	300		10	10
P11	P16	ABL	10.534466	76.201393	OH	Racoon		65		65
P16	P16-1	ABL Capital Village	10.53452	76.199145	UG	XLPE	300	324		324
P16-1	16	Capital Village	10.534929	76.199266	UG	XLPE	300	47	10	57
P16	17	Ushas	10.534124	76.201454	OH	Racoon		38		38

From Map no	Map no	Pole/transformer/ AB	Latitude	Longitude	Cable	Cable type	Cable size (sq mm)	Mapping distance (m)	Loose distance (m)	Total distance (m)
17	P17	Post	10.533884	76.201471	OH	Racoon		27		27
P17	18	Palissery Tower	10.53385	76.2017	OH	Racoon		25		25
P17	P18	Post	10.532924	76.201467	OH	Racoon		106		106
P18	P18-1	AB Kingsway	10.532924	76.201735	OH	Racoon		29		29
P18-1	19	Kingsway	10.532927	76.202019	UG	XLPE	300	31	30	61
P18	P19	AB Vincent Tower	10.532287	76.201529	OH	Racoon		71		71
P19	24	Vincent Tower	10.532218	76.201449	UG	XLPE	185	12	30	42
P19	P19-1	AB Cheloor	10.531996	76.201557	OH	Racoon		28		28
P19-1	20	Cheloor Apartment	10.531784	76.201361	UG	XLPE	185	47	50	97
P19-1	AB11	ABI-50914	10.531759	76.201555	OH	Racoon		45		45

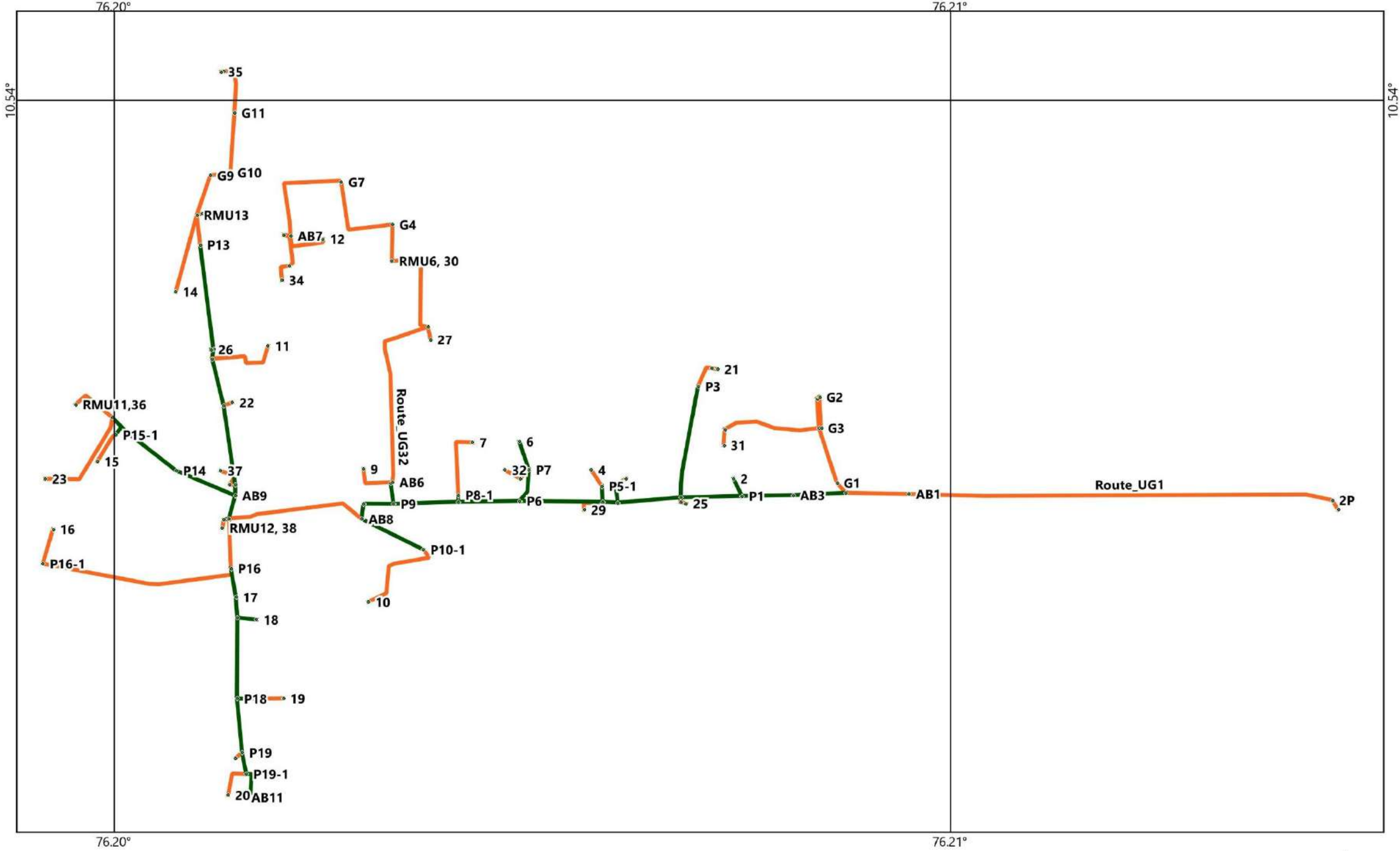

Poonkunam 22-23

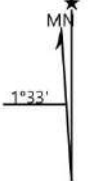
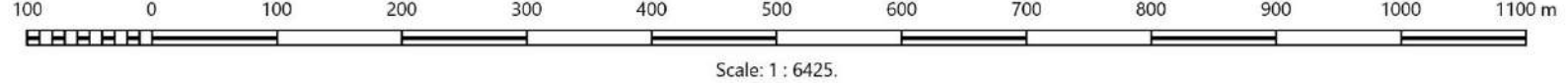

Figure 19: Poonkunam feeder

5. ENERGY CONSERVATION MEASURES SUMMARY

LIST OF ENERGY CONSERVATION PROPOSED FOR FUTURE

The TCED can consider following possible measures for energy conservation to reduce their distribution loss to their best value as summarised below.

➤ **Replacing HT & LT overhead lines with UG cables**

Even though TCED has initiated the replacement of overhead lines with underground cables, there are still areas in the distribution network with overhead lines. Sample analysis has been done for 04 number of feeders which were audited for the viability of replacing overhead lines with UG cables. Resistance per kilometre of the UG cables is less than the overhead lines which is Racocon type for HT and Rabbit type for LT in TCED. The replacement of HT & LT overhead lines with UG cables will result in reduction in energy losses in the distribution network and hence will lead to financial savings. The summary of the proposal is given in the table below.

Particulars	Units	Values
Annual Energy savings	MU	0.987
Annual financial savings	Rs in lakhs	65.67
Estimated investment	Rs in lakhs	175.46
Simple payback period	Months	32

➤ **Replacing Old Transformers with Energy Efficient transformers**

Among the 11 number of feeders audited, there were two number of old transformers in the Shoranur Road feeder which were aged more than 30 years and therefore these transformers are proposed to replace with energy efficient transformers as sample basis. This will result in the reduction in energy losses for the specified loading level of the transformer.

The details are summarized in the table below.

Particulars	Units	Values
Annual Energy savings	MU	0.01205
Annual financial savings	Rs in lakhs	0.80
Estimated investment	Rs in lakhs	14.0
Simple payback period	Years	17
	Months	210

➤ **Power Factor Improvement in Feeders**

The average power factor during the measurement period (5-hour logging) at 110kV incomer was 0.97 lagging. During the feeder level measurement, the PF was found to be less than 0.98 for 6 numbers of feeders for which power factor improvement can be done by installing capacitors of 60kVAr capacity each (in the secondary side of 5 distribution transformers in the feeders mentioned under 66kV incomer) and 120kVAr (in the secondary side of 15 distribution transformers in the feeders mentioned for feeders under 110kV incomer).

The annual financial savings occur via demand reduction, PF incentives and avoiding penalty.

The summary of the savings is given in the table below.

Particulars	Units	Values
Average reduction in monthly demand based on FY 23-24 data	kVA/month	822.7
Annual financial savings	Rs in lakhs	171.89
Estimated investment	Rs in lakhs	37.5
Simple payback period	Months	3

➤ **Summary of energy conservation measures**

Table 33: Energy conservation measures - summary

EC M No	Energy Efficiency Measures	Annual Electricity Savings	Annual Financial Savings	Investment	Fixed interest rate	Cash inflow	Net present value	Internal rate of return
		MU	(Rs)	(Rs)	%	Years	(Rs)	%
1	Replacing HT & LT overhead lines with UG cables***	0.987	65,67,690	1,75,45,800	8	5	42,07,222	18.36%
2	Replacing Two nos of Old Transformers with Energy Efficient transformers	0.01205	80,144	14,00,000	8	20	-6,13,139	1.32%
3	Power Factor Improvement in Feeders – installation of 420 kVAr total	-	1,71,89,369	37,50,000	8	1	1,21,66,082	358.38 %

***At 11 kV = 8.273 km & at 415 V = 20.97 km

➤ **General observations and suggestions**

Observation	Suggestions
<p>Collection efficiency of the DISCOM is 99.22% which resulted in reducing AT & C loss from 9.54 % (FY-2022-23) to 7.43% (FY-2023-24)</p> <p>As per the TCED availed data, the major dues are from the Government departments, urban local bodies, street light and corporation owned buildings.</p>	<p>Collection drives should be placed in the DISCOM area.</p> <p>Awareness shall be provided for the proper billing in due time.</p> <p>Energy cell can give awareness in the DSM and various energy efficiency measures to help them in reducing the consumption.</p>
<p>As the back-feed units from one feeder to another were not available in the DISCOM, exact loss analysis was unable to calculate from the existing data.</p>	<p>Feeder boundary energy meter is suitable option to have the back-feed data and records shall be maintained properly.</p>

LIST OF ENERGY CONSERVATION MEASURES ADOPTED/TAKEN

- **Feeder bifurcation:** - Previously, **Kottapuram feeder** supplied an average unit of 16.94 MU/month. It was subsequently bifurcated into **Kottapuram and Vanjikulam**, leading to the replacement of the overhead (OH) line (Racoon) with an ABC cable for a distance of 1.7 km. This replacement resulted in an annual loss reduction of 0.171 MU. Detailed calculations are provided in the table below.

Table 34: Energy Conservation measures adopted/taken

Particulars	Unit	Value
D&T losses of HT Racoon OH line cable before feeder bifurcation	kWh/annum	2,30,355
D&T losses of HT ABC OH line cable loss after feeder bifurcation	kWh/annum	58,752
Net Annual Unit Savings	kWh/annum	1,71,603
HT line Distance reconnected with ABC cable	m	1,700
Energy charges	Rs/kWh	6.50
Investment cost	Rs	50,00,000
Net Annual Financial Savings	Rs/annum	11,15,418
Simple payback period	Months	54

NOTE: Resistance of HT Racoon OH line cable = 0.3712 Ω /km
Resistance of HT ABC OH line = 0.25 Ω /km

ENERGY FLOW ANALYSIS

1. ENERGY FLOW

The basic energy flow in the DISCOM is given in the chart below.

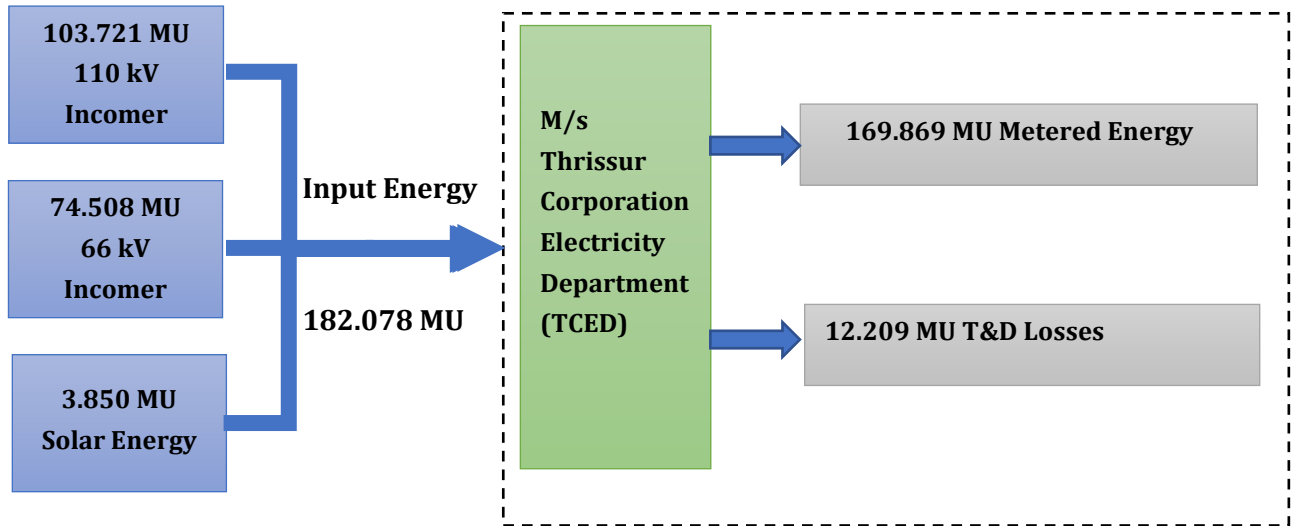

Figure 20: Energy flow diagram - TCED

- *Input energy = the energy received at the TCED for distribution.*
- *Metered energy = energy metered at the consumer end*
- *T&D losses = Net losses*

2. VALIDATION OF METERED DATA

The validation of data includes the KSEBL metering and feeder meters in the switching station of the TCED. The following tables will provide the validation of the metering by comparing with the calibrated power analyzers.

COMMERCIAL LOSSES

The auditors could not able to ascertain commercial losses/non-technical losses in the DISCOM during the FY 2023-24 due to the following factors.

1. Back feeding of one feeder to another during any failure in service, resulted in mixing up of consumption at the Feeder meter.
2. The record of meter errors was not readily available in section office to ascertain the losses caused in each feeder.
3. There is no theft reported in any sections during the audit period thus if any loss occurs in the commercial it could be due to the meter errors or damage.

Metering deviation was done in feeder incomer in order to derive an energy balance between purchase and sale. The energy meters at feeder incomer were cross checked using calibrated meters like Krykard ALM 35/ ALM 31.

DEVIATION OF METERING

- **Deviation of incomer meters**

The TCED incomer energy meters at the 110-kV substation were verified with power quality analysers and given in the table below.

Table 35: TCED incomer meter – deviation with PQ analyser

Sl no	Meter	KSEBL meter	Power analyser reading	KSEBL meter vs Power analyser
		kWh	kWh	%
1	110kV incomer	37.5	35.83	-4.661

- **Deviation of feeder meters**

Table 36: Deviation of feeder meters

Feeder No:	Feeder name	Panel reading	Average PF	Power analyser reading	Difference in consumption	% of error
		kWh		kWh	kWh	%
1	Mission Quarters	340	0.99	330	9.70	-2.94
2	Veliyanoor	280	0.98	275	5.50	-2.00
3	Koorkanchery	320	0.98	306	13.60	-4.44
4	Paravattani	460	0.98	448	12.00	-2.68
5	Aranattukkara	264	0.99	257	7.00	-2.72
6	Jubilee Medical College	387	1.00	381	6.10	-1.60
7	Vivekodayam	228	0.98	214	13.80	-6.44
8	Bini	512	0.99	502	10.50	-2.09
9	Poonkunnam	262	0.98	253	9.10	-3.59
10	Keralavarma	337	0.98	329	8.30	-2.52
11	Ramanilayam	366	0.99	352	13.60	-3.86
12	M.O Road	1,280	0.98	1,258	22.00	-1.75
13	Kottappuram	200	0.94	182	18.10	-9.95
14	Chembukavu	320	0.99	310	9.70	-3.13
15	Shornur Road	620	0.98	598	21.80	-3.64
16	District Hospital	570	0.99	553	16.60	-3.00
17	East fort	460	0.99	449	11.30	-2.52
18	Vanjikulam	159	1.00	156	3.20	-2.05

- *Considering the CT class variation among the Feeder meter and power analyzer, the errors observed are minimal except for vivekodhayam and kottappuram feeders.*
- *However, observed a variation 4.661% difference between the KSEBL and power analyzer meter in the 110-kV incomer. This could be due to the CT class difference variation with our power analyzer (1s) and the KSEBL meter (0.2s). Considering this, the difference is negligible and the meters are ok.*
- *Also, a mismatch observed in the energy meter readings for KSEBL and TCED feeder-wise meters. However, when we checked the TOD meter by bypassing the Potential Transformer (PT) and Current Transformer (CT), the values matched.*
- *Verify the CTs with periodic calibration and replace them if necessary.*

3. VALIDATION OF ENERGY FLOW DATA

The section provides the details of energy purchased and sold in the DISCOM

INCOMER - AT SWITCHING STATION

TCED procures electricity from KSEB Ltd for the supply to its consumers and for its own consumption. TCED receives the power as 110 kV and 66kV from the KSEBL (Kerala state electricity board limited) as **Part-C: BULK SUPPLY - EHT TARIFF APPLICABLE TO SMALL LICENSEES** category. The rates specified in this schedule (Part C) are exclusive of Electricity Duty and/or surcharge, other cess, taxes, minimum fees, duties and other impositions. Thus, only the demand and energy charges are applicable for the electricity cost.

- BASELINE DATA**

The basic details of the bill and TCED distribution are as follows:

Base Line Data - FY 2023-24		
1	Electricity provider	KSEBL
2	Supply Voltage	110 kV 66 kV
3	Tariff	Licensee: Thrissur Corporation- EHT TARIFF
4	Consumer number	LCN: 21/Thr.Corp LCN :21/1029
5	Section office	110 KV Sub Station, Viyyur
6	Contract demand (kVA)	Can access unlimited demand as per the agreement signed between KSEBL and Thrissur municipality on 1949.
7	Maximum demand registered (kVA)	26800 18112
8	Average monthly electricity consumption (MU)	8.64 6.21
9	Annual unit consumption (MU)	103.72 74.51
10	Average power factor	0.97 0.97
11	Tariff Rate of energy charges (Rs / kWh)	6.5
12	Revised tariff Rate of energy charges (Rs / kWh) from Nov- 2023	6.65
13	Demand charge (Rs / kVA)	380
14	Revised demand charge (Rs/ kVA) from Nov-2023	400
Other details		
15	Number of incoming feeders - From KSEBL - 110 kV and 66 kV (Nos)	02
16	Number of substations and voltage level	110 kV - Aswini - 01 no 66 kV Aswini - 01 no 33 kV Ikkanda warrier - 01 no
17	Number of TCED Distribution Feeders - 11 kV (Nos)	18
18	Feedback points - To KSEBL (Nos)	NIL
19	Number of transformers under TCED	480
20	Number of DT at 415V level	480
21	Number of s/s transformers at 33 kV level	01
22	Number of s/s transformers at 11 kV level	07
23	Line length at 33 kV voltage level (km)	4.2
24	Line length at 11 kV voltage level (km)	179.356
25	Line length at LT voltage level (km)	287.953
26	HT/LT ratio	1/2.335
27	Number of consumers - as of March 2024	42995
28	Connected load (MW) - as of March 2024	243.39
29	Number of HT consumers	139
30	Number of LT consumers	42856

• **DEMAND ANALYSIS**

DEMAND TARIFF STRUCTURE

As per the Kerala State Electricity regulatory commission (KSERC) tariff order dated 16/03/2020, Billing Demand (BD) shall be the Recorded Maximum Demand (RMD) for the month in kVA or 75% of Contract Demand (CD) whichever is higher in 30 minutes interval period.

TCED can access unlimited demand as per the agreement signed between KSEBL and Thrissur municipality on 1949.

The demand calculation for the TCED as per the KSERC order is given below. However this is not followed in the TCED billing as there is no mention of contract demand.

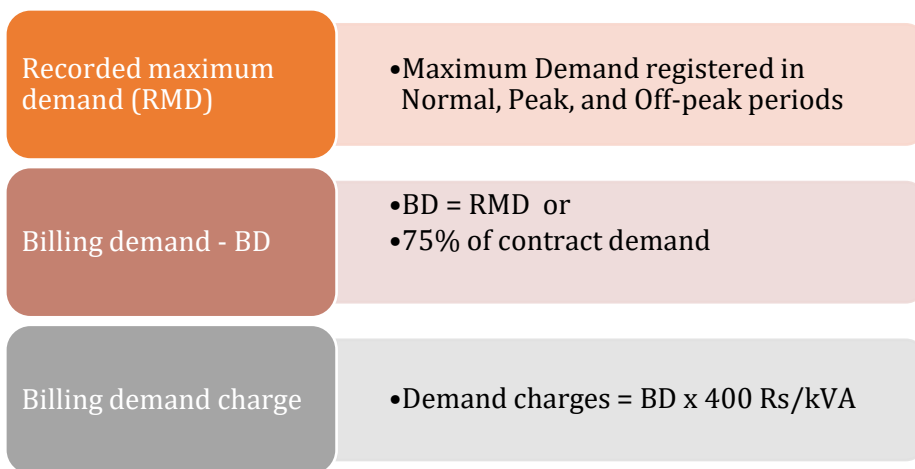

DEMAND REGISTERED - FY 2023-24

The registered or billed demand thus applied to the TCED and the consumption during the FY 2023-24 is given in the figure below.

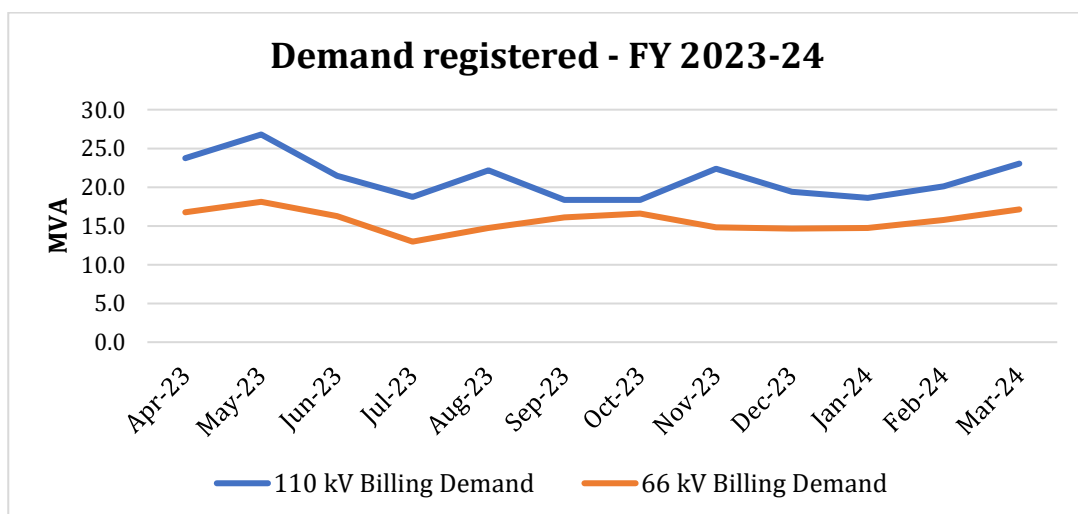

Figure 21: Demand variation – FY 2023-24

• **ENERGY CONSUMPTION ANALYSIS**

Energy Calculation Method

As per the Kerala State Electricity regulatory commission (KSERC) tariff order dated 16/03/2020, TOD tariff is applicable to Bulk consumer - Small licensees. The calculation method for the energy charges is mentioned below.

The calculation method for the energy charges is mentioned below.

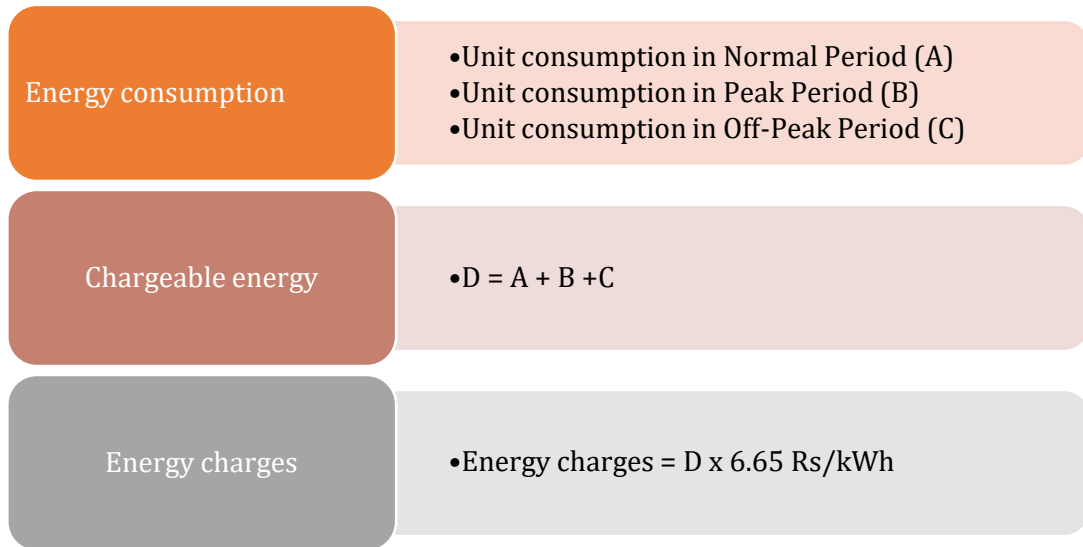

Unit Consumed – FY 2023-24

This section analyses the trend for the unit consumption by the TCED over the period FY 2023-24. A total of 178.23 MU consumed by TCED during FY 2023-24.

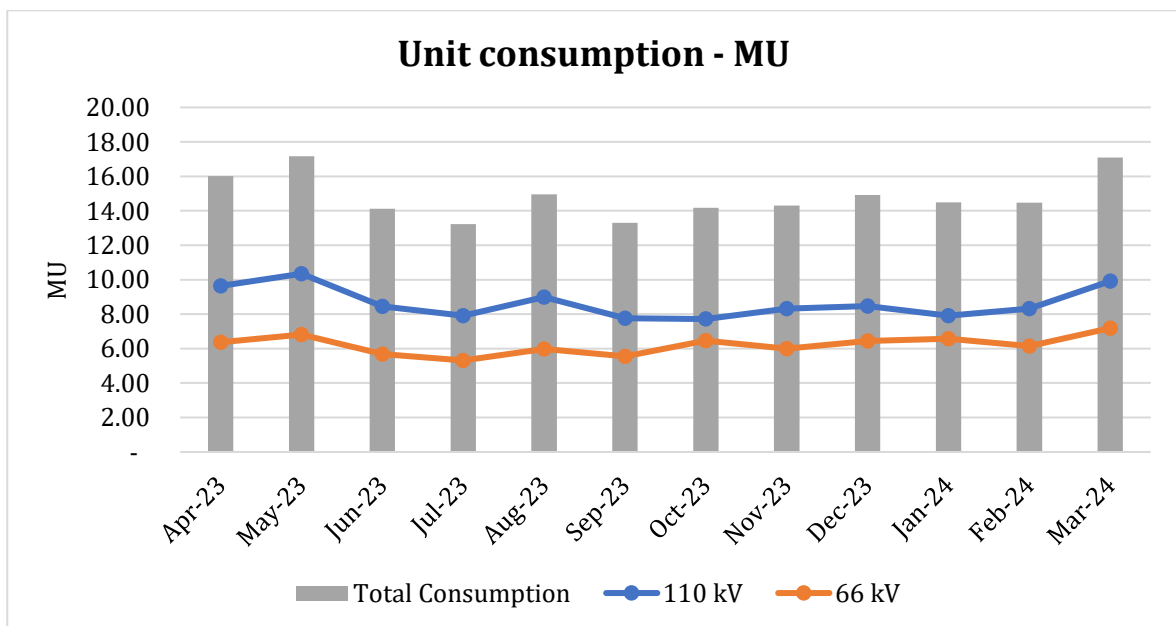

Figure 22: Energy consumption analysis

• **POWER FACTOR ANALYSIS**

Power factor calculation method

As per the Kerala State Electricity regulatory commission (KSERC) tariff order no: 0476/DD(T)/2020/KSERC dated 24/03/2022, power factor incentive/disincentives were applicable to Bulk consumer - Small licensees. The calculation method for the Power factor is mentioned below.

Active Energy consumption	•Denoted as (A)
Apparent Energy consumption	•Denoted as (B)
Power factor	• $PF = A \div B$
Power factor incentive	•For every increase of 0.01 from the 0.95 lagging, 0.5% of the energy charge will be provided as incentive.
PF disincentive	•For every decrease of 0.01 in the range of 0.95 to 0.90, 0.5% of the energy charge. •Less than 0.90 1% of energy charge.

During the audit period as per the new tariff the TCED is entitled to get PF incentive if it maintains above 0.95.

However, KSEB temporarily disapproved the PF incentive and presently in dispute.

Power factor registered in FY 2023-24

This section analyses the trend for the Power factor over the period FY 2023-24

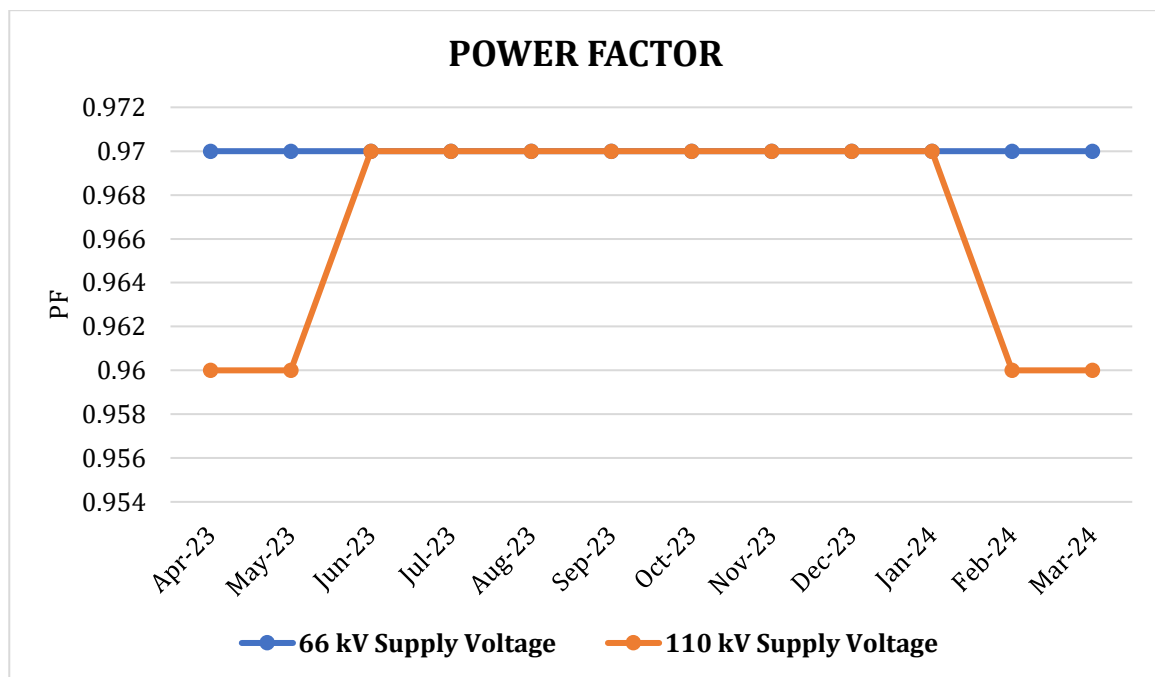

Figure 23: Power factor – FY 2023-24

• **OBSERVATIONS AND RECOMMENDATION – ENERGY CONSUMPTION PROFILE**

Table 37: Observations & Recommendation – Energy Consumption Profile

Observation	Recommendation	Benefit
Contract demand		
As per the 1947 agreement signed between TCED and KSEBL, unlimited supply warranty given for the former, meanwhile the TCED own generation was stopped as per the agreement.	<ul style="list-style-type: none"> • TCED is entitled to have unlimited Demand as per this agreement. 	No excess demand charges prevail in the DISCOM.
Power factor		
<p>Average power factor during 2023-24 is 0.97. Demand charges will reduce by ensuring the PF at near unity. The detailed calculation for the PF improvement is mentioned below in conclusion and action plans section.</p> <p>During the audit period as per the new tariff dated 25-06-2022 the TCED is entitled to get PF incentive if it maintains above 0.95. However, KSEBL temporarily disapproved the same and in dispute</p>	<ul style="list-style-type: none"> • Awareness shall be given to all the HT consumers for improving the PF near to unity. • Install capacitors for the distribution transformers (DT) in the 11 kV feeders wherever possible. • The selection of DT for reactive power compensation shall be based on their average loading. Choose the DT with an average loading of 40% and above. 	<ul style="list-style-type: none"> • The net annual savings by the PF improvement is 171.89 lakhs • In addition, the distribution line losses and transformer losses will get reduced.
Unit consumption analysis		
The overall unit purchased by the TCED during FY 2023-24 increased by 14.04% from the FY 2022-23 (FY 2022-23-unit purchased was 159.665MU).	NIL	<ul style="list-style-type: none"> • NIL

FEEDER WISE SALES DATA

The following table presents the units sold by the DISCOM during the fiscal year 2023-24, depicting the energy consumption of consumers categorized by feeder.

NOTE: Only data of 16 feeders out of 18 feeders was available during the audit period from the DISCOM

Table 38: Feeder wise sales data FY 2023-24

Sl no	Feeder Name	No: of Consumers	Energy sold by DISCOM	
		Nos	kWh/year	kWh/month
1	Mission Quaters	988	94,04,933	7,83,744
2	Veleyannor	1,940	74,63,821	6,21,985
3	Koorkenchery	3,062	97,31,425	8,10,952
4	Paravattany	2,984	83,06,391	6,92,199
6	JMC	2	89,35,392	7,44,616
7	Vivekodhayam	1,868	73,05,102	6,08,759
8	Bini	1,014	57,18,342	4,76,529
9	Poonkunam	2,476	77,53,356	6,46,113
10	Keralavarma	3,439	1,00,65,116	8,38,760
11	Ramanilayam	692	72,10,945	6,00,912
12	M O Road	2,567	1,14,53,015	9,54,418
14	Chembukkavu	2,727	1,02,17,614	8,51,468
15	Shornur Road	2,930	1,12,16,068	9,34,672
16	DH	3,199	1,10,65,664	9,22,139
17	East Fort	2,139	1,21,05,236	10,08,770
18	Vanjikulam	2,255	78,77,406	6,56,451
	Total	34,282	14,58,29,826	1,21,52,486

LOSS & SUBSIDY COMPUTATION

1. ENERGY ACCOUNTS ANALYSIS FOR PREVIOUS YEARS- FY 2022-23

The performance summary of TCED as DISCOM as per the FY 2022-23 is given in the following table.

Table 39: Summary of DISCOM – FY 2022-23

Performance Summary of Electricity Distribution Companies			
1	Period of Information Year of (FY) information including Date and Month (Start & End)	1st Apr, 2022 - 31st March, 2023	
2	Technical Details		
(a)	Energy Input Details		
(i)	Input Energy Purchase (From Generation Source)	Million kWh	159.665
(ii)	Net input energy (at DISCOM Periphery including sale outside periphery)	Million kWh	159.665
(iii)	Total Energy billed (is the Net energy billed, adjusted for energy traded)	Million kWh	148.36
(b)	Transmission and Distribution (T&D) loss	Million kWh	11.305
		%	7.08
	Collection Efficiency	%	97.36
	Billing Efficiency	%	92.92
(c)	Aggregate Technical & Commercial Loss	%	9.54

As the collection efficiency is 97.36% the AT&C loss of TCED registered was 9.54% during the FY 2022-23.

Table 40: AT & C loss – FY 2022-23

Name of circle	Period From 1st April 2022 to 31st March 2023									
	Consumer profile	Energy parameters			Losses		Commercial Parameter			AT & C loss (%)
	Consumer category	Input energy (MU)	Metered energy	% Of energy consumption	T&D loss (MU)	T&D loss (%)	Billed Amount in Rs. Crore	Collected Amount in Rs. Crore	Collection Efficiency	
TCED	159.665	159.665	40.10	27.00%	11.305	7.08	26.93	26.57	98.21%	9.54
	Agricultural		0.0538	0.04%			0.03	0.02	79.79%	
	Commercial/Industrial-LT		62.16	41.86%			69.10	66.25	93.49%	
	Commercial/Industrial-HT		44.84	29.98%			46.75	46.75	95.13%	
	Others		1.212	1.12%			0.57	0.00	0.00%	
Total	159.665	148.36	100%	11.305	7.08%	143.38	139.59	97.36%	9.54%	

2. ENERGY ACCOUNTS ANALYSIS FOR PRESENT YEAR- FY 2023-24

CATEGORY OF DIVISION WISE LOSSES - FY 2023-24

The consumer details, energy parameter and the overall circle wise T&D Losses are mentioned in the table below:

Table 41: Division wise losses

Division Wise Losses												
Period From 1st April 2023 to 31st March 2024												
Name of circle	Consumer profile					Energy parameters					Losses	
	Consumer category	No of connection metered (Nos)	No of connection Un-metered (Nos)	Total Number of connections (Nos)	% of number of connections	Input energy (MU)	Billed energy (MU)			% of energy consumption	T&D loss (MU)	T&D loss (%)
							Metered energy	Unmetered/assessment energy	Total energy			
TCED	Residential	23383	0	23383	54%	182.078	46.60	0	46.60	27.43%	12.209	6.71
	Agricultural	182	0	182	0.42%		0.06	0	0.06	0.03%		
	Commercial/Industrial-LT	18966	0	18966	44%		71.51	0	71.51	42.10%		
	Commercial/Industrial-HT	139	0	139	0.32%		50.53	0	50.53	29.75%		
	Others + Feedback	325	0	325	1%		1.17	0	1.17	0.69%		
Sub-total		42995	0	42995	100%	182.078	169.869	0	169.869	100%	12.209	6.71%

Methodology for T&D loss computation:

- T&D Losses (MU) of a circle = Sum of Input Energy of the circle (MU) – Sum of Metered energy of all categories within the circle (MU) – Feedback Energy (MU)
- T&D Losses in % = $\frac{\text{T\&D Losses (MU)}}{\text{Input Energy to the circle (MU)}} * 100$
- T&D Losses (MU) of a DISCOM = $\frac{\text{Sum of circlewise T\&D Losses (MU)}}{\text{Cumulative Sum of Input Energy (MU) to all circle}} * 100$

AGGREGATE TECHNICAL & COMMERCIAL (AT&C) LOSS

Aggregate Technical & Commercial Loss (AT&C Loss) is defined as the summation of all technical as well as commercial power loss that occurs due to electrical power flow through sub-transmission and distribution network.

Technical Loss is defined as the summation of power loss through 33 kV, 11 kV line and LT line loss including transformer loss and others.

Commercial Loss is defined as the summation of power loss occurring due to theft/ pilferage, deficient meter, inefficiency in billing & unrealized revenue due to collection inefficiency.

Computation of AT & C Loss:

Aggregate Technical & Commercial Loss (AT&C) is computed from the actual meter readings of the meter installed at various locations in the system.

- **Overall Billing Efficiency (%)** = Total Sale in MU/ Total input in MU
- **Overall Collection Efficiency (%)** = Total Collection Received (Rs. in Crs.) / Total Billing to Consumers (Rs. in Crs.)
- **AT & C Loss (%)** = 1- {Billing Efficiency % x Collection efficiency %}

As the collection efficiency is 99.22% the AT&C loss of TCED registered was 7.43% during the FY 2023-24.

Table 42: AT & C loss – FY 2023-24

S · No	Name of circle	Period From 1st April 2023 to 31st March 2024									
		Consumer profile	Energy parameters			Losses		Commercial Parameter			AT & C loss (%)
		Consumer category	Input energy (MU)	Metered energy	% Of energy consumption	T&D loss (MU)	T&D loss (%)	Billed Amount in Rs. Crore	Collected Amount in Rs. Crore	Collectio n Efficienc y	
1	TCED	Residential	182.0 78	46.60	27.00%	12.20 9	6.71	32.61	32.53	99.77%	7.43
		Agricultural		0.06	0.04%			0.03	0.03	93.42%	
		Commercial/ Industrial-LT		71.51	41.86%			80.13	79.24	98.90%	
		Commercial/ Industrial-HT		50.53	29.98%			54.04	53.70	99.37%	
		Others		1.17	1.12%			0.59	0.59	100.00%	
Sub-total		182.0 78	169.86 9	100%	12.20 9	6.71%	167.40	166.10	99.22%	7.43 %	

3. TECHNICAL LOSSES

Technical losses are subdivided into Four categories:

1. HT OH line & cable losses
2. Transformer loading & losses
3. LT OH line loss &
4. LT cable losses

The detailed calculation and the loss evaluation for 16 feeders is given in the sections below.

FEEDERWISE LINE LOSS CALCULATION

The details of OH lines used in the TCED distribution system is given in the table below. The HT line length was measured using the GPS mapping and LT line length was taken from the RDSS data.

Table 43: TCED Distribution -line details

Sl.No	Feeder	HT								LT
		OH Line Length	UG Cable length							OH line Length
			95 sq.mm	150 sq.mm	185 sq.mm	240 sq.mm	300 sq.mm	400 sq.mm	ABC - 120 sq mm	
m	m	m	m	m	m	m	m	m	m	
1	Bini	1838		63	122	354	1258.91		19	1710
2	Chembukavu	3,435		-	170	409	2,281		14	6,730
3	East Fort	2,119		73	47		4,641	56		9,900
4	Koorenchery	2,782		130	232	266	2,909			10,400
5	Ramanilayam	1,811		878	221		905			3,000
6	Veliyanoor	1,493			138	32	3,703			5,580
7	Vivekodhayam	2,120		40	124	86	2,508		20	5,500
8	Shornur Road	2,118		572	301		4,030			8,960
9	District Hospital	2,325		497	67	256	4,737			6,550

10	Jubilee Mission						2,821			NA
11	Arnattukkara	4,079				214	5,731		12	NA
12	Kottappuram	2,582		63	455		2,942			NA
13	Vanjikulam	2,173		164	310	185	1,957		1,728	11,900
14	Keralavarma	2,920		157	274	123	5,428		28	8,950
15	M O Road	1,736	170	149	480	266	5,159		26	10,200
16	Mission Quarters	4,507		135	23	31	4,704	39		10,150
17	Paravattani	3,163		272	111		5,053			10,450
18	Poonkunam	2,095		230	296		3,932			11,900
Total		43296	170	3423	3373	2221	64699	95	1846	121880

FEEDER WISE LINE LOSS

Feeder wise line loss calculation is given in the tables below. The calculations are based on month wise unit consumption and converted to yearly in the summary section.

The detailed calculation and the loss evaluation for 16 feeders is given in the sections below.

3.1 **BINI FEEDER**

Table 44: Loss analysis – Bini feeder

Mapping details					Up to Transformer primary or HT metering				From consumer		LT cable - secondary of transformer		Transformer loss			
From Map no	Map no	Pole/transformer /AB	Transformer ownership	Metering point	Cable	Total distance	Energy transmitted	HT OH line loss	Energy transmitted to consumer	LT OH line loss	Energy at pole near transformer	LT Cable line loss	Transmission at transformer secondary	Capacity of DT	Transformer loss	Transformer loss
						m	kWh/Month	kWh/month	kWh/Month	kWh/month	kWh/month	kWh/month	kWh/month	kVA	kW	kWh/month
	SS	Substation														
SS	2P	2P			UG	10										
RMU-30801	2	TT Devassy	Client	HT	UG	20										
					UG	104	14,469	0.06								
					OH	374	14,469	0.59								
P20	P7,29	Vadakke chira	Department	LT	OH	159										
					UG	74	19,006	0.05	17,175	1,386	18,561	12.53	18,577	250	1	429
					OH	785	19,006	1.61			18,561	4.14				
P8	4	Lake View	Client	LT	UG	31										
					UG	105	4,923	0.01			4,643	0.37	4,643	160	0	279
					OH	812	4,923	0.11								
P10	5	Seethal Appartment	Client	LT	UG	51										
					UG	126	7,041	0.01			6,633	2.56	6,636	250	1	405
					OH	979	7,041	0.28								
P10-1	6	Kalyan Jewellers	Client	HT	UG	71										
					UG	71	27,142	0.17								
					UG	74	27,142	0.15								
					OH	1,002	27,142	5.57								
					OH	454	27,068	2.51								

P13	3	Paliyam Road	Department	LT	OH	7											
					UG	74	59,737	0.53	47,996	10,965	58,961	101.12	59,062	250	1	675	
					OH	573	59,737	11.59									
P13-1	26	Ashiana Appartments	Client	LT	UG	56											
					UG	56	10,999	0.02									
					UG	74	10,999	0.02			10,451	1.97	10,453	315	1	547	
					OH	573	10,999	0.39									
ABL-50803	10	Pallithammam	Department	LT	UG	92											
					UG	92	26,095	0.15									
					UG	74	26,095	0.10	24,881	737	25,617	13.33	25,642	250	1	453	
					OH	786	26,095	3.03			25,617	11.14					
10	LBS,16	SBI- Pallithammam	Client	HT	UG	22											
					UG	22	11,548	0.01									
					UG	92	11,548	0.04									
					UG	74	11,548	0.03									
					OH	786	11,548	0.79									
LBS	12	Elite Supermarket(Pallithammam)	Client	HT	UG	6											
					UG	6	34,048	0.03									
					UG	92	34,048	0.35									
					UG	74	34,048	0.23									
					OH	786	34,048	6.88									
					UG	74	18,539	0.05			17,968	11.74	17,980	315	1	559	
					OH	786	18,539	1.53									
10	LBS,14	LBS, Kairali Sree Theatre 2	Client	HT	UG	16											
					UG	15	4,825	0.00									
					UG	16	4,825	0.00									
					UG	74	4,825	0.00									
					OH	786	4,825	0.14									
LBS	13	Kairali Sree Theatre 1	Client	LT	UG	54											

					UG	15	1,868	0.00								
					UG	16	1,868	0.00								
					UG	74	1,868	0.00			1,567	0.37	1,568	200	1	300
					OH	786	1,868	0.02								
P15	7	AGS Office	Department	LT	OH	7										
					UG	74	9,595	0.01			9,310	1.12	9,311	100	0	284
					OH	807	9,595	0.42								
7	8	Cochin Dewasm Board	Department	LT	OH	8										
					UG	74	678	0.00		-	-	-	-	500	1	678
					OH	815	678	0.00			-	-				
P16-2	9	Kailasam	Client	LT	UG	42										
					UG	117	3,471	0.00			3,193	0.31	3,193	160	0	277
					OH	944	3,471	0.06								
					OH	874	177	0.00								
G2	24	Vegetable	Department	LT	UG	309										
					UG	390	47,920	1.78			47,202	45.26	47,247	315	1	673
					OH	814	47,920	10.59								
G2	17	Dhanalakshmi Bank	Client	HT	UG	74										
					UG	464	31	0.00								
					OH	814	31	0.00								
P18	15	Chemmannur	Client	HT	UG	64										
					UG	64	8,359	0.01								
					UG	390	8,359	0.07								
					OH	841	8,359	0.44								
G7	21	Naduvilal(Pooma)	Department	LT	UG	22										
					UG	850	44,344	3.32			43,781	10.62	43,792	250	1	552
					OH	814	44,344	9.07								
21	20	Pooma Complex	Client	LT	UG	31										
					UG	31	15,967	0.03								
					UG	881	15,967	0.45			15,408	5.34	15,413	315	1	554

					OH	814	15,967	1.18								
P23	23, P23-1	Naduvial Shopping complex, Post	Department	LT	OH	61										
					UG	850	8,443	0.12			8,034	1.97	8,036	250	1	407
					OH	883	8,443	0.36								
P23-1	19	Sidish Complex	Client	LT	ABC	19										
AB-Ayodhya	18	Ayodhya centre	Client	LT	UG	33										
					UG	33	21,811	0.06								
					UG	943	21,811	0.89			21,240	4.12	21,244	315	1	567
					OH	883	21,811	2.38								
AB-Chungath	22	P22,Chugath Jewellery	Client	HT	UG	10										
					UG	860	8,824	0.18								
					OH	905	8,824	0.53								
P24	RMU-30802, 28	RMU-30802, National Lodge	Client	HT	UG	49										
					UG	909	11,318	0.31								
					OH	887	11,318	0.86								
P26	27	Maheswari Appartment	Client	HT	UG	29										
					UG	880	8,178	0.16								
					OH	933	8,178	0.47								
	NET SUM							71.18		13,087		228.87				7,901
	SS	Substation														

3.2 RAMANILAYAM FEEDER

Table 45: Loss analysis – Ramanilayam feeder

Mapping details					Up to Transformer primary or HT metering				From consumer		LT cable - secondary of transformer		Transformer loss			
From Map no	Map no	Pole/ transformer/AB	Transformer ownership	Metering point	Cable	Total distance	Energy transmitted	HT OH line loss	Energy transmitted to consumer	LT OH line loss	Energy at pole near transformer	LT Cable line loss	Transmission at transformer secondary	Capacity of DT	Transformer loss	Transformer loss
						m	kWh/Month	kWh/month	kWh/Month	kWh/month	kWh/month	kWh/month	kWh/month	kVA	kW	kWh/month
	S-S	Substation feeder														
S-S	P1	Post			UG	37										
P4	1	Stadium West	Department	LT	OH	10										
					UG	62	2,143	0.00			1,740	0.03	1,740	250	0.67	402
					OH	213	2,143	0.01			1,740	0.33				
P8	2, ABL51103	Stadium East	Department	LT	OH	189										
					UG	62	47,645	0.28	37,406	9,465	46,871	153.97	47,070	250	0.96	575
					OH	391	47,645	5.03			46,871	44.63				
G1	23	Indoor Stadium	Client	HT	UG	10										
					UG	72	11,038	0.02								
					OH	391	11,038	0.36								
AB Ramanilayam	3	Ramanilayam	Department	LT	OH	33										
					UG	254	5,216	0.01			4,935	0.67	4,936	150	0.47	280
					OH	570	5,216	0.09								
AB Pulimoottil	4	Pulimoottil	Client	HT	UG	38										

					UG	50	11,139	0.03								
					UG	254	11,139	0.08								
					OH	749	11,139	0.70								
AB Kaliyath	10	Kaliyath	Client	LT	UG	53										
					UG	53	11,637	0.01			10,969	1.83	10,972	400	1.11	665
					UG	254	11,637	0.14			10,969	0.90				
					OH	749	11,637	0.57								
AB-YMCA	8	YMCA	Client	HT	UG	70										
					UG	70	4,872	0.01								
					UG	254	4,872	0.02								
					OH	764	4,872	0.14								
AB Chiriyam Kandath	12	Chiriyam Kandath	Client	LT	UG	46										
					UG	254	22,690	0.26			22,317	18.68	22,336	200	0.59	354
					UG	46	22,690	0.09								
					OH	761	22,690	2.22								
AB-YMCA	9	Josco	Client	HT	UG	70										
					UG	70	14,676	0.08								
					UG	254	14,676	0.14								
					UG	254	1,08,020	7.85								
					OH	802	1,08,020	70.72								
G4	15	Vrindhavan Appartment	Client	LT	UG	62										
					UG	62	10,701	0.03			10,286	5.13	10,291	250	0.68	410
					UG	254	10,701	0.06								
					OH	833	10,701	0.54								
AB Vrindhavan	P13-1, 25	AB Josco, AB Kalanikethan, Kalanikethan	Depart ment	LT	OH	52										
					UG	254	22,646	0.32	21,728	541	22,269	13.41	22,283	160	0.61	363
					OH	885	22,646	3.14								
G6	19	New Josco	Client	HT	UG	104										

					UG	104	28,389	0.36								
					UG	254	28,389	0.54								
					OH	885	28,389	5.39								
P15	P16, 16	Swapana Theatre	Department	LT	OH	24										
					UG	254	22,830	0.24	21,832	550	22,382	10.22	22,392	250	0.73	438
					OH	981	22,830	2.67								
AB Kollanur	24	Kollanur	Client	LT	UG	28										
					UG	28	15,893	0.03			15,536	45.69	15,582	160	0.52	311
					UG	254	15,840	0.13			15,391	28.71	15,420	250	0.70	421
					OH	1,097	15,840	1.56								
P18	AB Statue & Alukkas, 17	Statue	Department	LT	OH	37										
					UG	254	26,602	0.32	23,628	2,503	26,131	21.00	26,152	250	0.75	451
					OH	1,114	26,602	4.05								
G9	20	Paramekavu Temple	Client	LT	UG	134										
					UG	389	5,409	0.02			5,005	0.77	5,006	250	0.67	404
					OH	1,172	5,409	0.19								
G12	18	Alukkas	Department	LT	UG	109										
					UG	363	39,966	1.15	36,528	2,726	39,254	170.18	39,453	250	0.85	512
					OH	1,114	39,966	10.08			39,254	29.33				
G9	28	Paramekavu SBI	Client	HT	UG	134										
					UG	134	16,735	0.03								
					OH	472	16,735	0.33								
RMU31102	27	Bharatiyar Vidhya Kendra	Client	HT	UG	148										
					UG	148	3,451	0.00								
					UG	254	3,451	0.00								
					OH	729	3,451	0.02								
					OH	811	2,438	0.03								

AB Capital Legend	7	Capital Legend	Client	LT	UG	25										
					UG	25	1,833	0.00			1,574	0.07	1,574	100	0.43	259
					UG	254	1,833	0.00								
					OH	943	1,833	0.02								
G15	AB ESI, 5	ESI	Department	LT	UG	284										
					UG	284	22,843	0.60	21,303	1,082	22,385	14.54	22,405	250	0.73	438
					UG	254	22,843	0.26			22,385	5.96				
					OH	685	22,843	2.02								
AB Capital City	22	Capital City	Client	LT	UG	41										
					UG	326	23,312	0.71			22,732	9.30	22,741	315	0.95	571
					UG	254	23,312	0.27								
					OH	728	23,312	2.24								
AB Perinchery	6	Perinchery	Client	LT	UG	68										
					UG	68	33,309	0.24			32,581	24.51	32,606	400	1.17	703
					UG	284	33,309	1.27								
					UG	254	33,309	0.56								
					OH	718	33,309	4.51								
	NET SUM							147.49		16,866		600.34				7,834

3.3 SHORNUR ROAD FEEDER

Table 46: Loss analysis – Shornur road feeder

Mapping details					Up to Transformer primary or HT metering				From consumer		LT cable - secondary of transformer		Transformer loss			
From Map no	Map no	Pole/transformer/AB	Transformer ownership	Metering point	Cable	Total distance	Energy transmitted	HT OH line loss	Energy transmitted to consumer	LT OH line loss	Energy at pole near transformer	LT Cable line loss	Transmission at transformer secondary	Capacity of DT	Transformer loss	Transformer loss
						m	kWh/Month	kWh/month	kWh/Month	kWh/month	kWh/month	kWh/month	kWh/month	kVA	kW	kWh/month
ss		Substation														
G1	ABL51502	AB			UG	126										
ABL51502	RMU31501, 35-Bismi	RMU31501, Bismi	Client	HT	UG	29										
					UG	155	33,205	0.41								
					OH	-	33,205	-								
RMU31501	36-Bismi	Bismi	Client	LT	UG	47										
					UG	202	1,997	0.00			1,337	0.15	1,337	400	1.10	660
					OH	-	1,997	-								
G3	RMU31502, 45-Pranavam Apartment	Pranavam Apartment	C/D	LT	UG	111										
					UG	266	26,910	0.37	25,261	1,052	26,313	140.50	26,454	250	0.76	456

					OH	-	26,910	-								
RMU31 503	46 - Top Orchid Appart ment	Top Orchid Appartment	Client	LT	UG	116										
					UG	116	7,361	0.02			7,077	0.76	7,078	160	0.47	283
					UG	266	7,361	0.03								
					OH	-	7,361	-								
AB-Sree	2- Sreelak shmi Silks	Sreelakshmi Silks	Client	LT	UG	53										
					UG	53	13,139	0.04			12,788	33.13	12,821	200	0.53	318
					UG	126	13,139	0.04								
					OH	76	13,139	0.07								
G6	03- Daffodil s	Daffodils	Client	LT	UG	53										
					UG	53	3,770	0.00			3,492	0.15	3,492	160	0.46	278
					UG	126	3,770	0.00								
					OH	149	3,770	0.01								
AB- Rukma ni2	26 - Rukma ni Temple Park	Rukmani Temple Park	Client	LT	UG	48										
					UG	48	4,470	0.00			4,168	0.13	4,168	200	0.50	302
					UG	263	4,470	0.01								
					OH	144	4,470	0.02								
AB- Rukmai 1	P5, 4- Karthay ani	Post, Karthayani	Departme nt	LT	OH	43										
					UG	126	59,486	0.86	55,335	3,365	58,700	118.4 0	58,819	250	1.11	667
					OH	187	59,486	3.67								
P5	AB, 23- K.R Bakery	K.R Bakery	Departme nt	LT	OH	17										

					UG	15										
					UG	141	43,758	0.52	39,595	2,277	41,872	25.37	43,031	500	1.21	727
					OH	204	43,758	2.16			41,872	62.78				
					UG	126	6,911	0.01			6,632	1.92				
					OH	187	6,911	0.05								
G13	21-Saraswathy	Saraswathy	Client	LT	UG	50										
					UG	176	3,254	0.00			2,844	0.78	2,851	250	0.67	403
					OH	316	3,254	0.02			2,844	0.05				
											2,844	6.12				
P9	22 - Unique Ardent	Unique Ardent	Department	LT	UG	28										
					UG	29	27,589	0.09	25,661	1,215	26,875	10.45	27,131	250	0.76	458
					UG	126	27,589	0.19			26,875	10.78				
					OH	442	27,589	1.87			26,875	234.32				
RMU31504	49-Panikath Mall	Panikath Mall	Client	LT	UG	47										
					UG	47	27,861	0.12			27,265	11.16	27,277	315	0.97	584
					UG	136	27,861	0.20								
					OH	314	27,861	1.35								
P40	P41, 18-Varnam	Post/Varnam	Department	LT	OH	172										
					UG	126	72,367	1.28	63,500	7,914	71,414	92.24	71,529	315	1.40	838
					OH	486	72,367	14.12			71,414	22.48				
P42	19-Omega Panthlon	Omega Panthlon	Client	LT	UG	43										
					UG	43	4,544	0.00			4,242	0.27	4,242	200	0.50	302
					UG	126	4,544	0.01								
					OH	521	10,884	0.34			10,462	10.61				
RMU31506	48-CKM Heights	CKM Heights	Client	LT	UG	85										

					UG	215	2,494	0.00			2,235	0.16	2,235	100	0.43	259
					OH	521	2,494	0.02								
G50	20- Nandhanam	Nandhanam	Client	LT	UG	312										
					UG	438	2,469	0.01			2,191	0.47	2,192	160	0.46	277
					OH	585	2,469	0.02			2,191	0.02				
P38	6- Kasturi	Kasturi (Bhramasam Madam)	Client	LT	OH	46										
					UG	312	3,088	0.01			2,827	0.61	2,827	100	0.43	260
					OH	268	3,088	0.01								
G17	7- Sreepriya	Sreepriya	Client	LT	UG	110										
					UG	422	3,114	0.01			2,812	1.33	2,813	200	0.50	301
					OH	222	3,114	0.01								
RMU31 507	42- Thrissur Service Cooperative Bank	Thrissur Service Cooperative Bank	Client	HT	UG	32										
					UG	32	5,708	0.00								
					UG	333	5,708	0.03								
					OH	277	5,708	0.06								
AB- Krishna	51- Capital Krishna	Capital Krishna	Client	LT	UG	34										
					UG	34	2,910	0.00			2,633	0.08	2,633	160	0.46	277
					UG	312	3,060	0.01			2,782	0.72	2,783	160	0.46	277
					OH	385	3,060	0.02								
AB- MRG	40 - MRG Sree Valstam	MRG Sree Valstam	Client	LT	UG	25										
					UG	25	9,411	0.01			9,001	2.53	9,003	250	0.68	408

					UG	480	9,411	0.08								
					OH	383	9,411	0.18								
AB-AR	27-A.R. Tower	A R Tower	Client	LT	UG	20										
					UG	20	5,775	0.00			5,508	0.68	5,509	100	0.44	266
					UG	312	5,775	0.02								
					OH	408	5,775	0.07								
P18	8-Krishna (Thiruvambadi-2)	Krishna(Thiruvambadi-2)	Department	LT	OH	9										
					UG	312	41,391	0.98	38,245	2,584	40,829	28.35	40,868	250	0.87	522
					OH	429	41,391	3.84			40,829	11.16				
											40,829	17.22				
P19	28-Friends Mall	Friends Mall	Client	LT	OH	12										
					UG	312	2,667	0.00			2,264	0.78	2,265	250	0.67	402
					OH	470	2,667	0.02								
RMU31 508	47-Oushadhi Panchakarma	Oushadhi Panchakarma	Client	HT	UG	81										
					UG	393	10,148	0.10								
					OH	481	10,148	0.34								
P22	P23, 11-Oushadhi	Oushadhi	Department	LT	OH	32										
					UG	475	4,024	0.01			3,722	0.37	3,722	200	0.50	301
					OH	635	4,024	0.05								
RMU31 510	44-Kalyan Hypermarket	Kalyan Hypermarket	Client	HT	UG	403										
					UG	1,055	91,244	21.10								

					OH	635	91,244	36.26								
P24	10- Thiruvambadi(Lekshmi)	Thiruvambadi(Lekshmi)	Department	LT	OH	1										
					UG	654	57,562	4.30	50,292	6,453	56,745	160.57	56,906	250	1.09	656
					OH	636	57,562	11.95								
G28	24- Narayani	Narayani	Client	LT	UG	101										
					UG	755	2,686	0.01			2,409	0.09	2,409	160	0.46	277
					OH	635	2,686	0.03								
P25	34- K.A Kumaran	K.A Kumaran	Department	LT	OH	10										
					UG	312	17,454	0.19	16,773	221	16,994	26.40	17,029	250	0.71	425
					OH	676	17,454	1.17			16,994	9.07				
AB- Saroja	25- Saroja	Saroja	Client	HT	UG	89										
					UG	401	27,596	0.73								
					OH	818	27,596	4.27								
P30	12- Suharsha	Suharsha	Client	LT	UG	26										
					UG	26	27,390	0.08			26,670	32.02	26,702	400	1.15	689
					UG	358	27,390	0.53								
					OH	990	40,991	11.41								
AB- Coperative	13- Coperative Hospital	Coperative Hospital	Department	LT	OH	2										
					UG	461	58,443	3.12	53,451	4,149	57,600	74.68	57,675	500	1.28	768
					OH	992	58,443	19.19								
AB- Athulya	16- Athulya	Athulya Chundari	Client	LT	UG	33										

	Chundari															
					UG	596	4,920	0.03			4,640	0.52	4,640	160	0.47	279
					OH	1,018	4,920	0.14								
G39	LBS	LBS			UG	166										
LBS	14-City Centre 1	City Centre 1	Client	LT	UG	3										
					UG	3	44,737	0.02			Busbar Connected		43,935	800	1.34	802
					UG	729	44,737	2.89								
					OH	1,035	44,737	11.73								
LBS	15-City Centre 2	City Centre 2	Client	LT	UG	12										
					UG	12	3,991	0.00			3,713	0.33	3,713	160	0.46	278
					UG	729	3,991	0.02								
					OH	1,035	3,991	0.09								
G41	39-Alukkas Nest	Alukkas Nest	Client	LT	UG	159										
					UG	722	8,519	0.10			8,181	1.62	8,182	215	0.56	337
					OH	1,080	45,723	11.78			44,690	40.76				
											44,690	435.17				
AB-Shivam	17-Shivam	Shivam	Client	LT	UG	42										
					UG	822	5,550	0.05			5,145	0.20	5,146	250	0.67	404
					OH	1,045	5,550	0.18								
P35	29-Ramdas Theatre	Ramdas Theatre	Client	HT	UG	36										
					UG	846	18,936	0.73								
					OH	1,098	18,936	2.70								
AB-Peninsula	30-Peninsula	Peninsula	Client	HT	UG	129										
					UG	129	22,476	0.32								

					UG	810	22,476	0.98								
					OH	1,101	22,476	3.81								
P36-1	31- Wintage e Royal	Wintage Royal	Client	LT	UG	63										
					UG	63	7,360	0.01			7,054	0.60	7,055	200	0.51	305
					UG	810	7,360	0.09								
					OH	1,081	7,360	0.33								
P37	37-Top Heritag e	Top Heritage	Client	LT	UG	40										
					UG	40	2,324	0.00			2,047	0.08	2,047	160	0.46	277
					UG	810	2,324	0.01								
					OH	1,126	2,324	0.03								
P37-1	38- Forus Cosyne st	Forus Cosynest	Client	LT	UG	36										
					UG	36	2,846	0.00			2,569	0.20	2,569	160	0.46	277
					UG	810	2,846	0.01								
					OH	1,136	2,846	0.05								
		Net Sum						206.23		35,072		2,920	.48			17,810

3.4 **CHEMBUKAVU FEEDER**

Table 47: Loss analysis - Chembukavu

Mapping details					Up to Transformer primary or HT metering				From consumer		LT cable - secondary of transformer		Transformer loss			
From Map no	Map no	Pole/transfo rmer/AB	Transf ormer owner ship	Mete ring point	Cable	Total distance	Energy transmitt ed	HT OH line loss	Energ y transmitted	LT OH line loss	Energy at pole near transfo rmer	LT Cable line loss	Trans mission at transfo rmer secondary	Cap acity of DT	Transf ormer loss	Trans form er loss
						m	kWh/ Month	kWh/ month	kWh/ Month	kWh/ month	kWh/ month	kWh/ month	kWh/ month	kVA	kW	KWh / month
	S-S	Substation feeder														
AB bb	1	Big Bazar	Client	HT	UG	53										
					UG	165	98,312	4.22								
					OH	9	98,312	0.68								
P3	RMU31 401, 2	Jawahar	Depart ment	LT	UG	126										
					UG	492	60,349	3.56	57,329	2,058	59,388	227.97	59,669	250	1.13	681
					OH	-	60,349	-			59,388	52.92				
G31	Asset Galleria	Asset Galleria(new TR)			UG	104										
					UG	715										
					OH	-										
G7	11	Swathy Residency	Client	LT	UG	84										
					UG	84	6,631	0.01								
					UG	119	6,631	0.01			6,224	1.88	6,226	250	0.68	405
					OH	-	6,631	-								
AB KSFE	15	KSFE	Client	HT	UG	27										

AB Central Hotel	10	Central Hotel	Client	HT	UG	54											
					UG	54	7,135	0.01									
					UG	874	7,135	0.12									
					OH	245	7,135	0.09									
RMU314 02	13	Agro	C/D	LT	UG	145											
					UG	1,019	48,688	4.79	39,660	8,275	47,935	169.75	48,105	250	0.97	583	
					OH	182	48,688	2.45									
G15	4, 5	Exchange 1& 2	Client	HT	UG	244											
					UG	244	82,279	5.39									
					UG	874	82,279	15.66									
					OH	411	82,279	21.00									
P10	9	Museum	Department	LT	OH	19											
					UG	874	93,867	15.28	60,259	31,839	92,098	626.60	92,814	315	1.76	1,053	
					OH	429	93,867	21.44			92,098	89.09					
G21	G22, 3	Co-operative Road	Department	LT	UG	209											
					UG	1,084	34,532	2.56	29,034	5,016	34,049	38.54	34,088	160	0.74	444	
					OH	714	34,532	4.82									
P11	P12, 14	Mana Line	Department	LT	OH	117											
					UG	933	1,110	0.00			852	0.34	852	100	0.43	258	
					OH	847	1,110	0.01									
AB Navani	12	Navani Holy View	Client	LT	UG	36											
					UG	36	4,212	0.00									
					UG	874	4,212	0.03			3,806	3.16	3,809	250	0.67	403	
					OH	1,026	4,212	0.10									
AB KMP	30	KMP Swapnapuri	Client	LT	UG	35											
					UG	35	4,174	0.00									
					UG	874	4,174	0.03			3,895	0.55	3,896	160	0.46	278	

					OH	1,120	4,174	0.11								
AB Caza	7	Cheloor Cazeblanka	Client	LT	UG	44										
					UG	44	3,483	0.00								
					UG	874	3,483	0.02			3,205	0.25	3,205	160	0.46	277
					OH	882	3,483	0.06								
P17	P18, 8	Southern	Department	LT	OH	69										
					UG	874	32,195	1.80	27,128	4,563	31,692	22.26	31,714	250	0.80	481
					OH	935	32,195	5.49								
RMU31403	16	Divya Ram Hospital (Atreya)	Client	HT	UG	61										
					UG	935	75,724	14.19								
					OH	1,181	75,724	51.14								
ABL51406	AB BP, 17	Bishop Palace	Department	LT	OH	151										
					UG	874	63,312	6.95	58,158	4,237	62,395	143.80	62,539	315	1.29	773
					OH	1,467	63,312	33.32								
P20	18	Kings fort	Department	LT	OH	14										
					UG	874	8,530	0.13	8,036	81	8,117	6.08	8,123	250	0.68	407
					OH	1,514	8,530	0.62								
					OH	14	8,530	0.00								
AB Sky Line	23	Skyline Garland	Client	LT	UG	64										
					UG	939	12,623	0.30			11,996	5.98	12,002	500	1.04	622
					OH	1,852	12,623	1.67								
P24	AB Soda varky, 20	Soda varky	Department	LT	OH	43										
					UG	874	75,407	9.86	62,265	12,141	74,406	163.59	74,570	250	1.40	837
					OH	1,895	75,407	61.03								
P25	21	Sarayu Apartment	Department	LT	OH	44										
					UG	874	50,003	4.34	43,216	5,849	49,065	53.35	49,410	250	0.99	593

					OH	1,971	50,003	27.92			49,065	291.77				
P31	ABI50409, 22	Panmukkumpilly Sastha Temple	Department	LT	OH	34										
					UG	874	47,535	3.92	43,369	3,534	46,903	40.63	46,960	250	0.96	575
					OH	2,264	47,535	28.98			46,903	16.51				
AB CTR	19	Cheloor Tudoor Rose	Client	LT	UG	27										
					UG	901	4,197	0.03			3,918	0.37	3,919	160	0.46	278
					OH	1,761	4,197	0.18								
AB Gayathri	26	Gayathri Apartment	Client	LT	UG	27										
					UG	901	5,533	0.05			5,128	0.64	5,129	250	0.67	404
					OH	1,835	5,533	0.32								
P36	25	Keeramkulangara	Department	LT	OH	66										
					UG	874	55,257	5.30	49,758	4,652	54,410	27.34	54,552	160	1.18	705
					OH	1,895	55,257	32.78			54,410	114.82				
G27	27	Sreyas Apartment	Client	LT	UG	58										
					UG	932	6,089	0.07			5,684	0.63	5,684	250	0.67	405
					OH	1,751	6,089	0.37								
RMU31405	29	Forus Apartment	Client	LT	UG	330										
					UG	1,240	3,203	0.03			2,902	0.06	2,902	200	0.50	301
					OH	1,748	3,203	0.10								
	NET SUM							403.13		84,105		2,117.92				11,455

3.5 JUBILEE MISSION COLLEGE FEEDER

Table 48: Loss analysis – JMC

Mapping details					Up to Transformer primary or HT metering			
From Map no	Map no	Pole/transformer/AB	Transformer ownership	Metering point	Cable	Total distance	Energy transmitted	HT OH line loss
						m	kWh/ Month	kWh/month
SS		Substation feeder			UG	10		
G17	01, 02 - Jubilee Mission	Jubilee Mission	Client	HT	UG	2811.34		
					UG	2821.34	7,44,616	4138.51
			NET SUM					4138.51

3.6 VIVEKODHAYAM FEEDER

Table 49: Loss analysis – Vivekodhayam

Mapping details					Up to Transformer primary or HT metering				From consumer		LT cable - secondary of transformer		Transformer loss			
From Map no	Map no	Pole/transformer/AB	Transformer ownership	Metering point	Cable	Total distance	Energy transmitted	HT OH line loss	Energy transmitted	LT OH line loss	Energy at pole near transformer	LT Cable line loss	Transmission at transformer secondary	Capacity of DT	Transformer loss	Transformer loss
						m	kWh/ Month	kWh/ month	kWh/ Month	kWh/ month	kWh/ month	kWh/ month	kWh/m onth	kVA	kW	KWh/ month
SS		Substation														
SS	P1	Substation feeder			UG	81										
P29	24	Aquatic(Sai)	Department	LT	OH	8										
					UG	81	39,628	0.25	31,440	7,429	38,869	238.03	39,107	250	0.87	522
					OH	100	39,628	0.89								

					OH	92	1,04,605	5.71								
G3	15	SG Complex	Client	HT	UG	18										
					UG	18	6,098	0.00								
					UG	81	6,098	0.01								
					OH	444	6,098	0.09								
G4	3	Govind Appartment	Client	LT	UG	24										
					UG	24	4,450	0.00			4,148	0.38	4,148	200	0.50	302
					UG	81	4,450	0.00								
					OH	446	4,450	0.05								
P6	AB1,P32, P32'29	AB Swimming pool, AB silver rox, ABL50702, Swimming Pool TR	Department	LT	OH	49										
					UG	81	52,424	0.44	42,580	9,084	51,664	147.88	51,812	250	1.02	612
					OH	289	52,424	4.51								
RM U1	28	Silver Roxx	Client	LT	UG	11										
					UG	11	10,280	0.00			9,967	1.49	9,969	200	0.52	311
					UG	167	10,280	0.03								
					OH	339	10,280	0.20								
P33	14	Kalindi	Client	LT	UG	57										
					UG	137	8,369	0.02			7,824	1.84	7,826	315	0.91	544
					OH	403	8,369	0.16								
P35	5	Vanvita	Client	HT	UG	31										
					UG	355	20,559	0.30								
					OH	514	20,559	1.23								
P10	6	Capital Manner	Department	LT	OH	7										
					UG	570	61,947	4.34	49,993	10,957	60,950	301.02	61,251	250	1.16	696
					OH	601	61,947	13.07								
P37	11	Sree Krishna Appartment	Client	LT	UG	108										
					UG	678	8,008	0.09			7,600	1.96	7,602	250	0.68	407

					OH	878	8,008	0.32								
P15	P38,07	AB-Souparnika, Souparnika	Department	LT	OH	4										
					UG	570	74,517	6.28	59,564	13,332	72,896	757.50	73,653	315	1.44	863
					OH	720	74,517	22.65								
G12	RMU2, 16	RMU30702, Mukundha Appartment	Client	LT	UG	48										
					UG	831	3,683	0.02			3,405	0.84	3,406	160	0.46	278
					OH	733	3,683	0.06								
P39	8	Satyam	Client	LT	UG	48										
					UG	918	5,612	0.06			5,332	0.34	5,332	160	0.47	280
					OH	733	5,612	0.13								
LBS (G)	12	Shivam	Client	LT	UG	39										
					UG	910	4,681	0.04			4,402	0.47	4,402	160	0.46	279
					OH	733	4,681	0.09								
					OH	845	3,250	0.05								
P20 -1	13	Mannath Lane(NP Tower)	Department	LT	OH	7										
					UG	783	23,744	0.88	21,543	1,744	23,288	12.02	23,300	250	0.74	445
					OH	1,052	23,744	3.36								
P41	10	Ambika Arcades	Client	LT	UG	61										
					UG	844	8,976	0.13			8,566	2.49	8,568	250	0.68	408
					OH	1,088	8,976	0.50								
P27	P45, 23	AB-Music Park, Music Park	Department	LT	OH	7										
					UG	783	63,510	6.27	49,900	12,476	62,376	359.28	62,735	315	1.29	774
					OH	1,113	63,510	25.44								
G19 -1	25	Anamya Tower	Client	LT	UG	52										
					UG	835	8,839	0.13			8,429	2.58	8,431	250	0.68	408
					OH	1,113	8,839	0.49								
P27	P28, 26	Post, Karuvan	Department	LT	OH	74										
					UG	783	53,401	4.43	43,212	9,356	52,568	127.59	52,696	315	1.18	705

					OH	1,180	53,401	19.06								
G28-1	RMU4, 30	RMU30703, Brahmasam Madom	Client	HT	UG	49										
					UG	831	50,332	4.18								
					OH	1,180	50,332	16.93								
P47	22	Capital Heritage	Client	LT	UG	27										
					UG	848	4,892	0.04			4,613	0.32	4,613	160	0.47	279
					OH	1,147	6,407	0.27								
P50	19	Karthiyayini	Client	LT	UG	124										
					UG	124	5,144	0.01			4,861	2.68	4,864	160	0.47	279
					UG	853	5,144	0.04								
					OH	1,162	5,144	0.17								
P51	20	Leo Enterprises	Client	HT	UG	50										
					UG	1,104	9,331	0.19								
					OH	1,147	9,331	0.57								
P52	18	Cochin Hall Mark	Client	HT	UG	21										
					UG	1,075	5,571	0.07								
					OH	1,147	5,571	0.20								
					ABC	23	5,571	0.00								
G18-1	RMU5, 17	RMU30704,Thiruvambadi Devasm	Client	HT	UG	337										
					UG	1,191	11,704	0.32								
					OH	1,162	11,704	0.90								
RMU5	27	Vrindavan Hotel	Client	HT	UG	51										
					UG	1,241	10,563	0.27								
					OH	1,162	10,563	0.73								
		SUM						151.83		64,379		1,959.15				9,072

3.7 VELIYANOOR FEEDER

Table 50: Loss analysis – Veliyanoor

Mapping details					Up to Transformer primary or HT metering				From consumer		LT cable - secondary of transformer		Transformer loss			
From Map no	Map no	Pole/trans former/AB	Trans former ownership	Met ering point	Cab le	Total distanc e	Energy transm itted	HT OH line loss	Energy transm itted	LT OH line loss	Energy at pole near transfo rmer	LT Cable line loss	Trans mission at transf ormer second ary	Capa city of DT	Transfo rmer loss	Transfo rmer loss
						m	kWh/ Month	kWh/ month	kWh/ Month	kWh/ month	kWh/ month	kWh/mo nth	kWh/ month	kVA	kW	KWh/ month
	S-S	Substation feeder														
S-S	P1	Post			UG	60.2										
P2	1	Assay Hall Marking	Depart ment	LT	OH	26.7										
					UG	60.2	10,096	0.01	9,519	284	9,802	1.06	9,806	160	0.48	290
					OH	34.38	10,096	0.02			9,802	2.34				
P1	P3, 21	Airtel Tower	Depart ment	LT	OH	19.76										
					UG	60.2	47,950	0.27	44,264	3,068	47,332	40.34	47,372	250	0.96	578
					OH	19.76	47,950	0.26								
P24	2	Manorama	Client	HT	UG	55										
					UG	115.2	21,382	0.10								
					OH	41.03	21,382	0.11								
G14	22	Chicago	Client	LT	UG	127.95										
					UG	188.15	24,338	0.22			23,647	8.39	23,655	400	1.14	683
					OH	7.68	24,338	0.03								
P25	3	C J Tower	C/D	LT	OH	24.38										
					UG	60.2	22,684	0.06			22,181	54.52	22,243	250	0.73	441

					OH	264.19	41,045	2.52								
RMU30 206	26	Edu Mart	Client	HT	UG	32.36										
					UG	32.36	32,727	0.08								
					UG	401.17	32,727	0.85								
					OH	264.19	32,727	1.60								
RMU30 202	14	Latin Palli	Department	LT	UG	323.63										
					UG	734.63	86,787	10.98	64,577	20,894	85,471	337.29	85,809	250	1.63	979
					OH	233.87	86,787	9.98								
G20	RMU30 203, 24	Vivid Press	Client	LT	UG	219.44										
					UG	954.07	4,079	0.03			3,817	0.24	3,817	100	0.44	262
					OH	233.87	4,079	0.02								
G32	RMU30 205, 25	Sakunthala	Client	HT	UG	141.99										
					UG	1365.1	22,493	1.37								
					OH	233.87	22,493	0.67								
AB OWC	20	OWC Plant	Department	LT	OH	4.02										
					UG	582.63	33,602	1.31	29,179	3,626	32,805	149.06	33,115	250	0.81	488
					OH	304.83	33,602	1.95			32,805	7.83				
											32,805	152.79				
P6	ABL502 04, 05	Ramanchir amadam	Department	LT	OH	240.67										
					UG	636.34	56,241	3.99	45,617	9,775	55,392	56.67	55,597	250	1.07	644
					OH	541.48	56,241	9.70			55,392	148.75				
P8	13	Hari Sree Appartmen t	Client	LT	OH	2.54										
					UG	736.35	1,938	0.01			1,661	0.02	1,661	160	0.46	276
					OH	544.02	1,938	0.01			1,661	0.05				

G10	ABL502 07, 7	Rashtra Deepika	Depart ment	LT	UG	321.88											
					UG	1058.23	41,886	3.68	36,316	4,956	41,272	78.45	41,350	250	0.89	536	
					OH	541.48	41,886	5.38									
RMU30 209	16	Rastra Deepika Press	Client	HT	UG	6.64											
					UG	6.64											
					UG	1066.44	-	-									
					OH	541.48	-	-									
AB Joypala ce	8	Joy palace	Client	HT	UG	30.43											
					UG	30.43	85,368										
					UG	1058.23	85,368	15.30									
					OH	605.49	2,375	0.02			1,973	0.13					
RMU30 210	23	New Jwala Diamond Jewellery	Client	LT	UG	146.3											
					UG	1204.53	7,175	0.12			6,887	4.60	6,892	160	0.47	283	
					OH	666.28	7,175	0.19									
G13	10	inland	Client	LT	UG	40.44											
					UG	40.44	7,524	0.01			6,975	5.90	6,981	315	0.90	543	
					UG	1058.23	7,524	0.12									
					OH	673.43	7,524	0.22									
AB PPY	15(Not connect ed)	P P Yohanan	Client		UG												
					UG	0	689	-			287	-	287	250	0.67	402	
					UG	636.34	689	0.00				-					
					OH	685.34	689	0.00									

G6	AB Jwala 2, 11	Jwala Diamond	Depart ment	LT	UG	77.9										
					UG	730.64	42,985	2.68	33,738	8,555	42,292	69.37	42,442	250	0.91	543
					OH	709.95	42,985	7.43			42,292	80.27				
AB Malaba r Tower	12	Malabar Tower	Client	LT	UG	60.32										
					UG	60.32										
					UG	652.74	402	0.00								
					OH	848.84	402	0.00								
AB Emeral d	18, 19	Emerald 1	Client	HT	UG	14.23										
					UG	28.46	3,229	0.00			2,952	0.13	2,952	160	0.46	277
					OH	1681.93	3,229	0.10								
AB Mani	6	Manichitra Arcades	Client	LT	UG	43.86										
					UG	680.2	1,936	0.01			1,635	0.25	1,636	200	0.50	300
					OH	703.74	1,936	0.01								
AB EMK	17	EMKE Silks	Client	HT	UG	79.52										
					UG	715.86	63,991	5.82								
					OH	729.37	63,991	16.92								
		Net SUM						131.38		57,096		1,244.97				8,966

3.8 EAST FORT FEEDER

Table 51: Loss analysis – East Fort

Mapping details					Up to Transformer primary or HT metering				From consumer		LT cable - secondary of transformer		Transformer loss			
From Map no	Map no	Pole/transformer/AB	Transformer ownership	Metering point	Cable	Total distance	Energy transmitted	HT OH line loss	Energy transmitted	LT OH line loss	Energy at pole near transformer	LT Cable line loss	Transmission at transformer	Capacity of DT	Transformer loss	Transformer loss

													second ary			
						m	kWh/ Month	kWh/ month	kWh/ Month	kWh/ month	kWh/ month	kWh/ month	kWh/m onth	kVA	kW	KWh/ month
SS	2P	Substation feeder			UG	25										SS
G12	RMU1/ 22	RMU31708, East Avenue	Client	LT	UG	94										G12
					UG	2,729	0.13			4,664	1.05	4,665	160	0.47	279	
					OH	74	0.01									
G13	RMU2/ 15	RMU31709, Navya Bakery	Client	HT	UG	58										G13
					UG	2,786	9.87									
					OH	74	0.74									
ABL517 05	10	Sun Tower	Client	LT	UG	28										ABL517 05
					UG	2,663	4.51			28,245	193.38	28,438	630	1.27	764	
					OH	99	0.48									
ABL517 05	32	E P Jose Commercial Building	Distribu tion	LT	OH	13										ABL517 05
					UG	2,635	21.93	53,240	10,652	63,892	150.78	64,043	250	1.21	723	
					OH	113	2.68									
P16	Selex Mall				UG	157										P16
	27	Selex Mall (KFC)	Client	HT	UG	10										
					UG	10	0.01									
					UG	2,792	1.41									
					UG	2,792	44.67									
					OH	99	4.54									
	29	Selex Mall LT Connection	Client	LT	UG	20										
					UG	20	0.08			53,027	102.24	53,129	400	1.29	774	
					UG	2,792	45.97									

					OH	99	0.57									
G11	11	Sindhooram Appartment	Client	LT	UG	137										G11
					UG	2,772	0.07			3,413	0.11	3,413	160	0.46	278	
					OH	225	0.02									
P11	1	Thomson Casa	Distribution	LT	UG	13										P11
					UG	2,649	7.10	32,777	3,364	36,141	137.20	36,278	160	0.78	466	
					OH	262	2.00									
P11	P12, 12	Pallikulam	Distribution	LT	OH	141										P11
					UG	2,635	1.94	16,802	2,122	18,923	4.34	18,952	160	0.55	328	
					OH	403	0.85			18,923	10.75					
										18,923	13.39					
P13	P23,33	AB-Chaldian,Chaldian	Distribution	LT	OH	4										P13
					UG	2,635	33.74	61,325	17,665	78,990	421.32	79,412	315	1.53	916	
					OH	483	17.66									
P13-1	34	Brothers Lane	Distribution	LT	OH	86										P13-1
					UG	2,635	10.51	36,952	6,842	43,794	201.46	43,996	100	1.38	830	
					OH	670	7.62									
P15	P15-1, 14	Post/Puthenpally	Distribution	LT	OH	134										P15
					UG	2,635	2.19	18,341	1,686	20,027	15.05	20,042	250	0.72	433	
					OH	896	2.13									
P15-1	RMU7,17	RMU31707,P I Babu	Distribution	LT	UG	24										P15-1
					UG	2,660	38.67	62,415	21,959	84,374	267.06	84,641	250	1.60	963	
					OH	896	37.20									
P5	AB4/04	ABL51704/Spoon (City Castle)	Distribution	LT	OH	41										P5
					UG	2,635	62.41	77,233	29,887	1,07,120	890.06	1,08,010	315	2.06	1,235	
					OH	115	7.80									
G9	Reliance(HT)	Reliance Super market	Client	HT	UG	10										G9

					UG	2,645	7.10									
					OH	115	0.88									
G9	6,5	Reliance-1(City Palace-1)	Client	LT	UG	100										G9
					UG	2,736	0.45			8,548	1.53	8,549	315	0.91	544	
					OH	115	0.05									
G9	6,5	Reliance-2(City Palace-2)	Client	LT	UG	100										G9
					UG	2,736	0.29			6,814	0.98	6,815	315	0.90	543	
					OH	189	1.12									
P21	7	Fort City	Distribution	LT	OH	29										P21
					UG	2,635	0.26	6,574	230	6,804	0.21	6,805	160	0.47	283	
					OH	217	0.06			6,804						
P17	8	Bharathakshema m	Client	LT	UG	72										P17
					UG	2,707	0.09			3,711	0.33	3,711	200	0.50	301	
					OH	292	0.03									
P18	9	Emmatty Tower	Client	LT	UG	26										P18
					UG	26	0.01			17,907	3.37	17,911	400	1.12	673	
					UG	2,635	1.81									
					OH	494	0.97									
RMU3	16	Candela Appartment	Client	LT	UG	37										RMU3
					UG	37	0.02			10,989	4.19	10,994	500	1.14	681	
					UG	2,635	0.71									
					OH	500	0.39									
P20	25	St-Thomas College	Client	HT	UG	16										P20
					UG	2,651	0.25									
					OH	653	0.18									
AB St-Thomas	26/ABI 51604	Iyyunni	Distribution	LT	OH	28										AB St-Thomas
					UG	2,635	41.50	71,804	16,146	87,950	127.68	88,078	250	1.68	1,009	
					OH	681	30.61									
P10	23	Kings Way Project	Client	LT	UG	90										P10

					UG	2,726	0.36			7,858	1.46	7,859	100	0.46	276	
					OH	141	0.05									
ABL 51708	3	Honest Bakery	Distribution	LT	OH	20										ABL 51708
					UG	167	0.51	32,159	6,477	38,636	27.57	38,664	315	1.05	629	
					OH	2,635	23.05									
ABL 51708	RMU4, 20	RMU31703, Angelic Tower	Client	LT	UG	81										ABL 51708
					UG	2,716	17.73			56,270	285.07	56,626	315	1.22	731	
					OH	148	2.75			56,270	71.27					
G10	RMU5, 19	RMU 31704, Lorde Pally	Client	HT	UG	200										G10
					UG	2,835	1.29									
					OH	148	0.19									
RMU6	18	East Fort Tower	Client	LT	UG	111										RMU6
					UG	2,947	0.07			3,128	0.15	3,128	200	0.50	301	
					OH	148	0.01									
RMU8	30/31	E Forts Unlimited(HT), E Forts(LT)	Client	HT, LT	UG	73										RMU8
					UG	73	0.24			7,838	1.49	28,698	200	0.65	389	
					UG	2,760	4.63									
					OH	245	1.17									
RMU9	21	Rappai & Sons	Client	LT	UG	305										RMU9
					UG	2,991	0.28			6,467	2.03	6,469	250	0.68	405	
					OH	245	0.07									
			Net SUM				539.19		1,28,431		3,029.16				15,957	
RMU9	21	Rappai & Sons	Client	LT	UG	305										RMU9
					UG	2,991	0.28			6,467	2.03	6,469	250	0.68	405	
					OH	245	0.07									
			Net SUM				539.19		1,28,431		3,029.16				15,957	

3.9 **KERALAVARMA FEEDER**

Table 52: Loss analysis – Keralavarma

Mapping details					Up to Transformer primary or HT metering				From consumer		LT cable - secondary of transformer		Transformer loss			
From Map no	Map no	Pole/transfo rmer/AB	Transf ormer owners hip	Met erin g poi nt	Cab le	Total distan ce	Energy trans mitted	HT OH line loss	Energy transm itted	LT OH line loss	Energy at pole near transfo rmer	LT Cable line loss	Transmiss ion at transform er secondary	Cap acit y of DT	Trans forme r loss	Transf ormer loss
						m	kWh/ Month	kWh/ month	kWh/ Month	kWh/ month	kWh/ month	kWh/ month h	kWh/mont h	kVA	kW	KWh/ month
	S-S	Substation feeder														
SS	2P	post			UG	10										
G19	ABL51003	ABL51003			UG	112										
ABL51003	1	Omega genting palace	Client	LT	UG	35										
					OH	28	4,327	0.00			3,994	0.77	3,995	200	0.55	332
					UG	2,225	4,327	0.08								
					UG	35	4,327	0.00								
P3-2	2	CIDBI	Client	LT	UG	73										
					OH	32	8,984	0.01			8,317	3.63	8,321	400	1.10	663
					UG	2,246	8,984	0.36								
					UG	73	8,984	0.02								
P3-3	3	Sreesankari	Depart ment	LT	UG	52										
					OH	32	4,149	0.00	3,760	111	3,870	0.14	3,871	160	0.46	278
					UG	2,294	4,149	0.22			3,870	0.73				
					UG	52	4,149	0.00								
P5	RMU,37	Zudio	Client	LT	UG	25										

					OH	161	32,175	0.94			31,297	278.13	31,575	315	1.00	599
					UG	2,086	32,175	4.28								
					UG	25	32,175	0.08								
P6	RMU3 1003,3 4	MC TOWER	Client	LT	UG	50										
					OH	204	48,803	2.76			47,876	137.58	48,125	315	1.13	678
					UG	2,136	48,803	10.09			47,876	111.12				
P7-1	4	CA arcade	Client	LT	UG	36										
					OH	311	5,771	0.06			5,490	1.36	5,491	160	0.47	280
					UG	2,086	5,771	0.14								
					UG	36	5,771	0.00								
ABL51 004	25	falkland	Client	LT	UG	61										
					OH	348	14,778	0.43			14,350	9.75	14,360	250	0.70	418
					UG	2,146	14,778	0.93								
RMU3 1004	27	chirang Apartment	Client	LT	UG	59										
					OH	370	7,433	0.12			7,097	0.57	7,097	200	0.56	335
					UG	2,145	7,433	0.24								
P10-2	5	Coral Apartment	Client	LT	UG	19										
					OH	484	6,127	0.10			5,585	0.76	5,585	315	0.90	542
					UG	2,123	6,127	0.16								
					UG	19	6,127	0.00								
P10	P11,6	Kerala Varma Bus stop	Depart ment	LT	OH	31										
					OH	501	79,959	6.35	63,679	15,238	78,916	150.96	79,067	250	1.49	892

					UG	2,086	79,959	75.55								
RMU3 1005	31	Palaise Grande App	Client	LT	UG	74										
P13	7	Kerala Varma Hostel	Department	LT	OH	132										
					OH	851	86,297	12.58	70,794	14,125	84,919	79.91	85,323	315	1.62	974
					UG	2,086	86,297	88.00			84,919	324.62				
P16-1	9	Temple Tower	Client	LT	UG	62										
					OH	1,077	3,913	0.09			3,510	0.28	3,510	250	0.67	403
					UG	2,086	3,913	0.06								
					UG	62	3,913	0.00								
P19	10	Mahamaya App	Client	LT	OH	4										
					OH	1,238	2,277	0.04			2,017	0.62	2,018	100	0.43	259
					UG	2,086	2,277	0.02								
ABL57 007	11	Sreedurga App	Department	LT	UG	143										
					OH	1,254	2,918	0.02	2,594	63	2,657	1.07	2,658	100	0.43	260
					UG	2,229	2,918	0.11								
P20-1	12	Blue Hills	Client	LT	UG	32										
					OH	1,318	2,192	0.04			1,933	0.09	1,933	100	0.43	259
					UG	2,124	2,192	0.02								
					UG	32	2,192	0.00								
7	RMU3 1006, 30	Capital Green App	Client	LT	UG	104										
					OH	851	15,929	1.22			15,258	1.05	15,259	400	1.12	669
					UG	2,190	15,929	1.10								
RMU3 1007	32	Forus	Client	LT	UG	30										

G23	ABL51 009, 08	Kerala Varma	Client	LT	UG	442										
					OH	851	75,87 5	27.76			74,623	71.99	75,032	250	1.40	843
					UG	2,528	75,87 5	28.87			74,623	337.4 5				
G31	22	Chungam	Depart ment	LT	UG	804										
					OH	851	49,89 4	4.20	39,744	9,398	49,142	22.30	49,302	250	0.99	592
					UG	3,332	49,89 4	46.99			49,142	137.7 0				
P21	35	Model Road	Depart ment	LT	OH	286										
					OH	1,137	21,11 9	1.01	18,149	2,579	20,727	1.59	20,734	100	0.64	385
					UG	3,332	21,11 9	8.42			20,727	5.21				
G32	21	Central Park	Client	LT	UG	70										
					OH	1,137	12,11 7	0.95			11,762	10.35	11,772	200	0.58	345
					UG	3,402	12,11 7	0.99								
P26	13	NP Tower	Depart ment	LT	OH	24										
					OH	770	56,45 5	4.87	45,923	9,246	55,169	56.21	55,730	315	1.21	725
					UG	2,086	56,45 5	37.66			55,169	504.1 4				
P27-1	15	Capital Symphony	Client	LT	UG	36										
					OH	834	5,261	0.13			4,927	1.18	4,928	200	0.55	333
					UG	2,122	5,261	0.12								
P28	14	Bhadra App	Client	LT	UG	52										
					OH	867	4,260	0.09			3,982	-	3,982	160	0.46	278

					UG	2,086	4,260	0.08								
					UG	2,198	32,926	13.50								
RMU3 1008	33	Ansari Complex	Client	LT	UG	40										
					OH	687	15,685	0.96			15,258	6.45	15,265	250	0.70	420
					UG	2,248	15,685	1.10								
P29-1	16	Westfort Hospital	Client	HT	UG	33										
					OH	687	56,995	16.86								
					UG	28	56,995	0.60								
					UG	2,318	56,995	19.92								
P30	17	Haya Tower	Client	LT	UG	53										
					OH	760	9,706	0.41			9,040	2.38	9,043	400	1.11	663
					UG	2,338	9,706	0.44								
P32-1	29	Jyothi Tower	Client	LT	UG	36										
					OH	879	16,109	1.29			15,676	11.91	15,688	250	0.70	421
					UG	2,321	16,109	1.19								
P33	18	Westfort	Department	LT	OH	50										
					OH	914	80,882	11.87	63,491	16,411	79,902	77.38	79,979	250	1.50	903
					UG	2,285	80,882	84.69								
RMU3 1009	26	PV Arcade	Client	LT	UG	148										
					OH	977	6,845	0.26			6,507	3.17	6,510	200	0.56	335
					UG	2,448	6,845	0.23								
P34-2	23	TipTop	Client	HT	UG	36										

					OH	985	35,547	7.05								
					UG	2,285	80,061	82.98								
P38	20	Westfort Tower	Client	LT	UG	28										
					OH	1,064	16,537	1.65			15,974	7.42	15,982	315	0.93	555
					UG	2,285	16,537	1.24								
					UG	28	16,537	0.02								
RMU3 1010	28	Chowallur Tower	Client	LT	UG	64										
					OH	1,064	7,311	0.32			6,649	0.40	6,649	400	1.10	662
					UG	2,395	7,311	0.25								
RMU3 1011	36	Puthenpural Tower	Client	LT	UG	72										
					OH	1,064	8,068	0.39			7,780	3.67	7,783	160	0.47	285
					UG	2,403	8,068	0.31								
			NET SUM					642.86		84,062		2,586.83				17,959

3.10 MISSION QUARTERS FEEDER

Table 53: Loss analysis – Mission Quarters

Mapping details					Up to Transformer primary or HT metering				From consumer		LT cable - secondary of transformer		Transformer loss			
From Map no	Map no	Pole/transformer /AB	Transformer ownership	Metering point	Cable	Total distance	Energy transmitted	HT OH line loss	Energy transmitted	LT OH line loss	Energy at pole near transformer	LT Cable line loss	Transmission at transformer secondary	Capacity of DT	Transformer loss	Transformer loss
						m	kWh/Month	kWh/month	kWh/Month	kWh/month	kWh/month	kWh/month	kWh/month	kVA	kW	KWh/month
	SS	Substation Feeder			UG											
SS	P1	Post			UG	19										
G6	25	Millenium Kuries	Client	LT	UG	189										
					UG	208	14,463	0.09			14,155	2.43	14,158	160	0.51	305
					OH	3	14,463	0.00								
RMU2	27	Alice Legacy	Client	LT	UG	60										
					UG	641	9,910	0.12			9,245	2.15	9,247	400	1.11	663
					OH	-	9,910	-								
RMU2	11	Sky Tower	Client	LT	UG	200										
					UG	789	10,101	0.16			9,810	1.87	9,811	160	0.48	290
					OH	-	10,101	-								
AB2	AB3,02(D)	ABI50103, Fathima Nagar, (ABFN)	Department	LT	OH	53										
					UG	913	51,610	4.83	43,625	7,152	50,776	27.08	50,916	315	1.16	694
					OH	53	51,610	0.80			50,776	112.49				
AB5	1	Navani Heights(C)	Client	LT	UG	25										
					UG	938	9,334	0.16			8,775	13.87	8,789	315	0.91	545
					OH	119	9,334	0.06								
AB6	21 (c)	Navani Garden	Client	LT	UG	31										
					UG	31	7,805	0.00			7,257	4.86	7,261	315	0.91	543

					UG	39	13,112	0.00								
					UG	913	13,112	0.14								
					OH	29	13,112	0.01								
AB8	3	Muttichuokaran (C/D) 250	C/D	LT	OH	70										
					UG	913	36,978	2.48	29,694	6,627	36,320	3.96	36,471	250	0.84	506
					OH	279	36,978	2.16			36,320	19.49				
											36,320	127.90				
P7	AB9, AB10, 04	ABL50105, AB joy, Kallu Shapp (D) 250	Department	LT	OH	142										
					UG	913	67,146	8.17	53,572	12,582	66,154	105.07	66,399	250	1.25	747
					OH	350	67,146	8.95			66,154	74.26				
											66,154	65.67				
RMU5	28	RMU30105, Joy Alukkas HT 315kVA	Client	HT	UG	122										
					UG	1,036	26,438	0.64								
					OH	350	26,438	0.62								
G15	RMU7,30	RMU30107, Kalyan Hyper Market (c)	Client	LT	UG	76										
					UG	989	15,394	0.47			14,974	-	14,974	250	0.70	420
					OH	396	15,394	0.53								
RMU8	32 (C)	Precious Home 315	Client	LT	UG	412										
					UG	1,325	9,061	0.22			8,510	6.52	8,517	315	0.91	544
					OH	624	47,322	7.92								
AB13	23 (c)	Pleasant hill	Client	LT	UG	43										
					UG	43	4,259	0.00			3,978	2.99	3,980	160	0.46	278
					UG	913	4,259	0.03								
					OH	1,043	4,259	0.11								
P14	09,AB14	AB-Microwave, Microwave (D) 150kVA	Department	LT	OH	24										
					UG	913	17,908	0.58	15,952	1,594	17,546	13.82	17,559	100	0.58	349
					OH	1,059	17,908	1.93								
AB14	10(c)	BSNL Microwave (C) HT 160	Client	HT	OH	40										

					UG	913	39,263	1.24								
					OH	1,099	39,263	4.27								
AB15	12 (c)	Chemmannam 160	Client	LT	UG	100										
					UG	1,013	2,603	0.01			2,327	0.13	2,327	160	0.46	277
					OH	1,066	2,603	0.04								
RMU10	34 (C)	ESAF Jazz Tower (C)	Client	LT	UG	52										
					UG	966	17,826	0.61			17,499	7.42	17,506	160	0.53	320
					OH	1,314	17,826	2.37								
P21	14 (D), AB19	AB SIB,SIB (D), 500	Department	LT	OH	4										
					UG	913	83,979	12.78	65,382	17,403	82,784	253.14	83,037	250	1.57	942
					OH	1,378	83,979	55.06								
AB Vasan	16 (c)	Vasan Eye Care (HT)	Client	HT	UG	32										
					UG	945	5,707	0.03								
					OH	1,476	5,707	0.12								
AB Das	17 (c)	Das Continental HT	Client	HT	UG	74										
					UG	987	61,666	3.31								
					OH	1,512	61,666	14.48								
P32	13(D)	St. Joseph's (D) 315	Department	LT	OH	9										
					UG	913	28,575	1.48	24,292	3,696	27,988	-	27,988	315	0.98	587
					OH	1,236	28,575	5.72			27,988	-				
P29	20 (c)	Retreat apartment	Client	LT	OH	147										
					UG	913	43,367	3.41			42,668	16.39	42,718	315	1.08	649
					OH	1,559	43,367	16.61			42,668	33.62				
												-				
G24	22 (c)	Skyline Infinity (Mundupalam)	Client	LT	UG	145										
					UG	1,059	11,525	0.28			10,851	8.48	10,860	400	1.11	665
					OH	1,443	11,525	1.09								
RMU9	26 (C)	Asset 400	Client	LT	UG	23										
					UG	23	19,666	0.03			18,976	15.13	18,991	400	1.12	675
					UG	1,012	19,666	0.78								

					OH	1,455	19,666	3.19								
P38	5	Xavy Thekkath 05	Client	LT	OH	55										
					UG	913	5,430	0.05			5,163	0.80	5,164	100	0.44	266
					OH	589	5,430	0.10								
AB25	RMU6, 29(c)	RMU30106, Aquatic 160kVA	Client	LT	UG	48										
					UG	961	8,187	0.13			7,900	1.87	7,902	160	0.48	285
					OH	739	8,187	0.28								
AB26	19(C)	Federal Residency 500	Client	LT	UG	61										
					UG	974	16,836	0.55			16,036	115.76	16,151	500	1.14	685
					OH	837	16,836	1.34								
P43	06 (D), P43-1	Post, Swimming Pool	Department	LT	OH	187										
					UG	913	33,638	2.05	28,194	4,979	33,173	13.21	33,218	200	0.70	420
					OH	805	33,638	5.16			33,173	32.52				
P50	33 (D), P50-1	Mulberry Department	Department	LT	OH	93										
					UG	913	23,377	0.99	20,344	2,592	22,936	7.65	22,963	100	0.69	414
					OH	1,183	23,377	3.66			22,936	18.95				
AB27	18	Mulberry	Client	LT	UG	92										
					UG	92	9,204	0.03			8,893	3.32	8,896	200	0.51	309
					UG	913	9,204	0.15								
					OH	1,236	9,204	0.59								
G32	24 (D), P52-1	SN Temple 250	Department	LT	UG	290										
					UG	1,035	1,500	0.00			-	-	-	630	1.25	750
					OH	1,264	1,500	0.02					-	630	1.25	750
		NET SUM						237.60		82,118		1,440.64				15,599

3.11 PARAVATTANY FEEDER

Table 54: Loss analysis – Paravattany

Mapping details					Up to Transformer primary or HT metering				From consumer		LT cable - secondary of transformer		Transformer loss			
From Map no	Map no	Pole/transf ormer/AB	Transfo rmer owners hip	Mete ring point	Ca ble	Total dista nce	Energy transm itted	HT OH line loss	Energy transm itted	LT OH line loss	Energy at pole near transf ormer	LT Cable line loss	Transmi ssion at transf ormer seconda ry	Capa city of DT	Transfo rmer loss	Transfo rmer loss
						m	kWh/ Month	kWh/ month	kWh/M onth	kWh/ month	kWh/mo nth	kWh /month	kWh/m onth	kVA	kW	KWh/ month
	S-S	Substation feeder														
P1	P1-1	AB-Jose Pottukaran			OH	4										
P1-1	11	Jose pottokoran	Client	LT	UG	38										
					UG	999	9,121	0.16			8,810	2.58	8,813	200	0.51	308
					OH	34	9,121	0.02								
P1-1	Life Scan	Lifescan (315 kVA)	Client	HT	UG	18										
					UG	979	33,888	2.70								
					OH	34	33,888	0.27								
P2	ABn, Fathima	ABL New, Fathima (250 kVA)	Distribu tion	LT	OH	55										
					UG	961	-	-		-	-	-	-	250	-	-
					OH	167	-	-		-	-	-				
P2-1	9	Manjali Enclave	Client	LT	UG	40										
					UG	40	2,959	0.00			2,681	0.11	2,682	160	0.46	277
					UG	961	2,959	0.02								
					OH	176	2,959	0.01								

P3-1	1	YAS Residency/T T Complex	Client	LT	UG	51										
					UG	1,012	8,224	0.13			7,938	0.75	7,939	160	0.47	285
					OH	503	13,393	0.50								
					ABC	34	13,393	0.02								
AB3	2	Andrews	Distribution	LT	OH	6										
					UG	961	77,222	11.14	63,681	12,436	76,116	104.78	76,373	250	1.42	849
					OH	621	77,222	20.55			76,116	151.28				
P7	10	In Land/Fortune Appartment	Client	LT	UG	15										
					UG	1,226	5,617	0.08			5,312	2.07	5,314	200	0.51	303
					OH	757	5,617	0.13								
RMU10	23	CIDBI Appartment	Client	LT	UG	70										
					UG	70	5,940	0.01			5,278	1.43	5,279	400	1.10	661
					UG	1,380	5,940	0.09								
					OH	757	5,940	0.15								
P8-1	25	Pentark East Park	Client	LT	UG	61										
					UG	61	5,120	0.01			4,817	0.51	4,818	200	0.50	302
					UG	1,463	5,120	0.07								
					OH	900	5,120	0.13								
P10-1	8	Wheels Appartment	Client	LT	UG	27										
					UG	27	2,053	0.00			1,777	0.15	1,777	160	0.46	276
					UG	1,111	14,572	0.57								
					OH	621	14,572	0.90								

AB4	P5, 3	Post, Unnimossa	Distribution	LT	OH	11										
					UG	1,217	67,512	10.78	54,679	11,919	66,598	130.35	66,768	250	1.24	744
					OH	632	67,512	15.99			66,598	39.71				
AB4	RMU2, 14	RMU30402, Sundale Apartment	Client	LT	UG	68										
					UG	1,853	5,397	0.10			5,094	0.76	5,095	200	0.50	303
					OH	621	5,397	0.10								
RMU2	RMU3, 27	RMU30403, Able Tower	Distribution	LT	UG	158										
					UG	2,011	-	-			-	-	-	250	-	-
					OH	621	-	-			-	-				
											-	-				
P5	16	Homeo	Distribution	LT	OH	163										
					UG	1,217	36,882	3.22	29,674	6,481	36,154	89.98	36,244	100	1.06	638
					OH	796	36,882	6.00								
AB6	5	Paravattani Park	Distribution	LT	OH	115										
					UG	1,217	1,22,797	35.65	1,00,183	21,545	1,21,728	-	1,21,728	500	1.78	1,069
					OH	1,206	19,568	3.17								
P13	6	Paravattani	Distribution	LT	OH	161										
					UG	1,267	1,13,706	31.83	91,891	18,126	1,10,017	266.79	1,12,336	250	2.28	1,370
					OH	1,599	1,13,706	114.72			1,10,017	328.36				
											1,10,017	1,723.86				

P14-1	18	Store	Distribution	LT	UG	110										
					UG	1,377	1,547	0.01	1,256	15	1,271	0.12	1,271	160	0.46	276
					OH	1,951	1,547	0.03			1,271	0.04				
											1,271	0.12				
AB6	17	Double Horse	Distribution	LT	OH	163										
					UG	632	14,559	0.26	12,684	1,480	14,165	4.76	14,243	100	0.53	317
					OH	1,164	14,559	1.37			14,165	73.48				
RMU8	26	Asset Precious	Client	LT	UG	43										
					UG	696	14,905	0.30			14,234	2.50	14,237	400	1.11	668
					OH	1,389	14,905	1.71								
AB7	13	Deepak Tom(Jeweli ma Diamonds)	Client	HT	UG	166										
					UG	798	12,154	0.28								
					OH	1,576	39,353	13.54			38,622	159.34				
AB7	AB8, 7	Kankapadan, ABI-50107	Distribution	LT	OH	80										
					UG	939	60,864	6.76	50,058	9,990	60,048	136.94	60,185	250	1.13	680
					OH	1,576	60,864	32.40								
G12	AB10, 4	ABL-50407/ABL-50408, Ottu company	Distribution	LT	UG	24										
					UG	2,007	69,518	18.84	56,506	11,750	68,256	68.46	68,577	160	1.57	940
					OH	632	69,518	16.95			68,256	252.78				
G17	RMU2, 19	RMU-30404, Pookuzhydam	Distribution	LT	UG	144										
					UG	2,200	40,555	7.03	33,635	6,245	39,880	35.06	40,030	250	0.87	525

					OH	632	40,555	5.77			39,880	115.06				
RMU3	20	Mystic Rose(Mulberry)	Client	LT	UG	46										
					UG	46	10,951	0.02			10,279	7.45	10,287	400	1.11	664
					UG	2,719	10,951	0.63								
					OH	632	10,951	0.42								
RMU4	21	Nirmalamatha	Client	HT	UG	139										
					UG	139	207	0.00								
					UG	2,848	207	0.00								
					OH	632	207	0.00								
		NET SUM						464.79		99,986		3,759.23				12,640

3.12 KOORKKENCHERY FEEDER

Table 55: Loss analysis – Koorkkenchery

Mapping details					Up to Transformer primary or HT metering				From consumer		LT cable - secondary of transformer		Transformer loss			
From Map no	Map no	Pole/transf ormer/AB	Transfo rmer owners hip	Mete ring point	Ca ble	Total distanc e	Energy transm itted	HT OH line loss	Energy transm itted	LT OH line loss	Energy at pole near transf ormer	LT Cable line loss	Transmi ssion at transf ormer seconda ry	Capa city of DT	Transfo rmer loss	Transfo rmer loss
						m	kWh/ Month	kWh /month	kWh/M onth	kWh/ month	kWh/mo nth	kWh /month	kWh/m onth	kVA	kW	KWh/ month
	S-S	Substation feeder														

S-S	P1	Post			UG	11										
	1	Commercial	Department	LT												
					UG	989	60,265	7.13	47,827	11,461	59,287	51.12	59,514	315	1.25	751
					OH	217	60,265	4.46			59,287	175.27				
G4	2	Casino	Client	HT	UG	67										
					UG	67	39,640	0.26								
					UG	1,020	39,640	3.18								
					OH	217	39,640	1.93								
G5	3	Smart Centre	Department	LT	UG	103										
					UG	1,092	2,375	0.01	2,085	30	2,115	0.42	2,116	100	0.43	259
					OH	377	2,375	0.01			2,115					
G6	4	Sree Sailam	Client	LT	UG	116										
					UG	1,105	9,432	0.20			9,017	1.18	9,024	250	0.68	408
					OH	470	9,432	0.24			9,017	1.98				
											9,017	3.08				
P9-1	5	Metro	Client	HT	UG	104										
					UG	104	41,585	0.58								
					UG	989	41,585	3.39								
					OH	697	41,585	6.83								
RMU3	26	CK Plaza	Client	LT	UG	54										
					UG	1,053	10,713	0.24			10,417	3.95	10,421	160	0.49	292
					OH	736	10,713	0.48								
P10	6	Alumkulam	Department	LT	OH	27										
					UG	989	36,076	2.55	30,362	5,196	35,559	16.35	35,575	250	0.84	501
					OH	763	36,076	5.63								
G7	10	Thankamani	Department	LT	UG	199										
					UG	199	99,247	4.78	62,481	36,675	99,156	90.79	99,247	250		-
					UG	989	99,247	19.33								
					OH	763	99,247	42.58								
P11-1	8	Skyline	Client	LT	UG	32										

					UG	199	18,054				18,040	13.67	18,054	630		-
					UG	1,020	18,054	0.66								
					OH	876	18,054	1.62								
P13-1	9	Love-Shore	Client	LT	UG	108										
					UG	108	12,828	0.07			12,057	6.87	12,064	700	1.27	764
					UG	199	12,828	0.08								
					UG	989	12,828	0.32								
					OH	993	12,828	0.93								
P13	7	Kaja	Department	LT	OH	47										
					UG	199	67,545	2.21	47,515	19,089	66,604	108.14	66,794	250	1.25	751
					UG	989	67,545	8.95			66,604	81.93				
					OH	1,025	67,545	26.50								
RMU4	11	Mannanthara Agencies	Client	LT	UG	57										
					UG	1,076	9,562	0.20			9,270	3.12	9,273	160	0.48	288
					OH	1,009	9,562	0.52								
P17	15	Smart City	Client	LT	OH	15										
					UG	989	32,131	2.03			31,548	72.38	31,650	250	0.80	480
					OH	1,293	32,131	7.56			31,548	29.87				
15	24	I-Vision	Client	HT	UG	142										
					UG	1,131	12,185	0.33								
					OH	1,293	12,185	1.09								
P18	17	Hi-Life	Client	LT	UG	173										
					UG	1,161	2,805	0.02			2,542	3.06	2,545	100	0.43	260
					OH	1,398	2,805	0.06								
RMU5	25	Shangri-La-Fortune	Client	LT	UG	53										
					UG	1,057	10,513	0.23			9,847	2.35	9,849	400	1.11	664
					OH	1,451	10,513	0.91								
AB4	16	Sun City	Client	LT	OH	51										
					UG	989	66,406	8.65			64,524	100.92	65,610	315	1.33	796
					OH	1,502	66,406	37.52			64,524	985.14				

P21	13	Kanjirangadi	Department	LT	OH	184										
					UG	989	73,497	10.60	55,792	16,571	72,364	317.33	72,681	250	1.36	816
					OH	1,522	73,497	46.58								
					UG	1,086	2,513	0.01	2,237	16	2,253	0.62	2,253	100	0.43	260
					OH	1,731	2,513	0.06								
P20	12	Kinar	Department	LT	OH	28										
					UG	989	62,475	7.66	45,086	16,550	61,636	138.13	61,774	250	1.17	701
					OH	1,366	62,475	30.20			61,636					
P5	18	Veterinary	Department	LT	OH	12										
					UG	989	20,703	0.84	19,114	1,144	20,258	9.95	20,268	250	0.72	434
					OH	322	20,703	0.78								
18	19	Dee Pee Plaza	Department	LT	OH	66										
					UG	989	53,629	5.64	45,057	7,629	52,686	235.50	52,922	315	1.18	707
					OH	388	53,629	6.32								
P21	20	Dhanya	Department	LT	OH	7										
					UG	989	1,09,170	23.38	84,901	22,573	1,07,473	383.97	1,07,857	250	2.19	1,313
					OH	569	1,09,170	38.42								
P21-1	22,23	Railway	Client	HT,H T	UG	128										
					UG	128	59,735	1.46								
					UG	989	59,735	7.00								
					OH	590	59,735	11.93								
AB6	21	Ice Plant	Department	LT	OH	35										
					UG	989	53,080	5.53	45,480	6,477	51,957	65.44	52,023	100	1.76	1,058
					OH	713	53,080	11.39								
RMU7	27	Forus Apartment	Client	LT	UG	22										

					UG	22	2,884	0.00				2,607	0.08	2,607	160	0.46	277
					UG	1,708	2,884	0.03									
					OH	679	2,884	0.03									
			SUM														11,780
								412.13				1,43,411		2,902.61			

3.13 POONKUNAM FEEDER

Table 56: Loss analysis – Poonkunam

Mapping details					Up to Transformer primary or HT metering				From consumer		LT cable - secondary of transformer		Transformer loss			
From Map no	Map no	Pole/transf ormer/AB	Transfo rmer owners hip	Mete ring point	Ca ble	Total dista nce	Energy transm itted	HT OH line loss	Energy transm itted	LT OH line loss	Energy at pole near transf ormer	LT Cable line loss	Transmi ssion at transf ormer seconda ry	Capa city of DT	Transfo rmer loss	Transfo rmer loss
						m	kWh/ Month	kWh/ month	kWh/M onth	kWh/ month	kWh/mo nth	kWh /month	kWh/m onth	kVA	kW	KWh/ month
	ss	Substation Feeder														
G1	01, AB4	Omega Swami Saranam, ABL 50905	Distribu tion	LT	UG	98										
					UG	781	18,641	0.49	18,254	2.50		18,254	5.59	18,319	160	0.54
												18,254	25.67			
												18,254	33.94			
ABL4	RMU1, 28	Sarong Homes Appartment, RMU30901	C/D	LT	UG	98		-								

					UG	879	36,489	2.11	35,786	12.03		35,786	21.47	35,992	250	0.83
												35,786	140.92			
												35,786	43.48			
RMU 2	31	Pallissery Apartment	Client	LT	UG	21										
					UG	1,074	11,053	0.24				10,759	2.55	10,761	160	0.49
P1	2	Classic Park	Distribution	LT	OH	25										
					UG	683	2,590	0.01	2,330	0.01		2,330	0.63	2,330	100	0.43
					OH	161	2,590	0.01								
P2-1	25	Falkland Square	Client	HT	UG	33										
					UG	715	2,077	0.01								
					OH	221	2,077	0.00								
P3-1	21	Westend Krishna Apartment	Client	LT	UG	60										
					UG	777	4,044	0.02				3,742	0.19	3,742	200	0.50
					OH	363	4,044	0.03								
P4-1	3	Capital Harmony	Client	LT	UG	51										
					UG	51	3,038	0.00				2,761	0.10	2,761	160	0.46
					UG	683	3,038	0.01								
					OH	322	3,038	0.02								
P5-1	4	Omega Crown	Client	LT	UG	75										
					UG	75	3,125	0.00				2,824	0.08	2,824	200	0.50
					UG	683	3,125	0.01								
					OH	339	3,125	0.02								
P5	5	Ramadevi-1	Distribution	LT	UG	32										
					UG	714	61,772	4.91	60,668	27.66		60,668	325.94	60,994	500	1.30
					OH	319	61,772	6.25								

RMU3	29	Aricaria Jyothi Nest Appartment	Client	LT	UG	82										
					UG	791	10,188	0.01				9,877	0.80	9,877	200	0.52
					OH	319	10,188	0.36								
RMU4	32	Ephatha	Client	HT	UG	73										
					UG	73	8,642	-								
					UG	734	8,642	0.01								
					OH	472	8,642	-								
P7	6	Lakshmi Appartment	C/D	LT	OH	39										
					UG	683	18,446	0.42	18,091	2.25		18,091	8.23	18,099	100	0.58
					OH	511	18,446	0.89								
P8-1	7	Kalyan	Client	HT	UG	91										
					UG	774	41,740	1.48								
					OH	516	41,740	0.35								
P9	8	Sitaram Mill	Distribution	LT	OH	28										
					UG	683	14,678	0.26	14,254	1.02		14,254	5.11	14,259	250	0.70
					OH	620	14,678	0.69								
AB6	9	Dhanalaxmi Office	Client	HT	UG	54										
					UG	737	77,879	8.46								
					OH	622	77,879	16.11								
RMU5	27	Gulmohar Appartment	Client	LT	UG	17										
					UG	17	3,916	0.00				3,654	0.23	3,654	100	0.44
					UG	927	3,916	0.03								
					OH	622	3,916	0.05								
RMU6	30	Ground Water	Distribution	LT	UG	10										
					UG	1,071	40,921	3.23	40,345	12.23		40,345	54.59	40,399	250	0.87
					OH	622	40,921	5.36								

RMU7	33	SreeRam Temple	Distribution	LT	UG	10										
					UG	1,409	695	0.00	293	0.00		293	0.01	293	250	0.67
					OH	622	695	0.00								
RMU8	34	Top Tulip	Client	LT	UG	29										
					UG	1,476	3,178	0.03				2,901	0.28	2,901	160	0.46
					OH	622	3,178	0.03								
AB7	12	Ram Nikethan	Client	LT	UG	60										
					UG	1,445	7,388	0.14				6,980	2.14	6,982	250	0.68
					OH	622	7,388	0.17								
P10-1	10	Sree Sailam	Distribution	LT	UG	130										
					UG	813	10,520	0.16	10,109	0.26		10,109	1.71	10,110	250	0.68
					OH	742	10,520	0.42								
RMU10	37	Sayooj Haridas	Client	LT	UG	33										
					UG	33	9,779	0.01				9,467	2.96	9,470	200	0.52
					UG	882	9,779	0.15								
					OH	697	9,779	0.34								
P11-1	22	Neelambari Apartment	Client	LT	UG	12										
					UG	887	8,325	0.11				7,662	0.56	7,663	400	1.10
					OH	802	8,325	0.29								
P11-2	11	Capital Horizon	Client	LT	UG	97										
					UG	972	5,775	0.06				5,492	2.66	5,495	160	0.47
					OH	865	5,775	0.15								
P12	26	Ramachandra Apartment	Distribution	LT	OH	3										
					UG	875	3,320	0.02	3,041	0.02		3,041	1.22	3,042	160	0.46
					OH	880	3,320	0.05								
RMU13	13	Pushpagiri	Distribution	LT	UG	7										

					UG	883	64,312	6.58	63,454	12.61		63,454	76.80	63,531	500	1.30
					OH	1,003	64,312	21.35								
RMU13	14	Vijay Sai	Client	LT	UG	104										
					UG	104	5,419	0.01				5,116	0.36	5,116	200	0.50
					UG	875	5,419	0.05								
					OH	1,003	5,419	0.15								
RMU9	35	Krishna Saketh	Client	LT	UG	14										
					UG	1,116	2,095	0.01				1,819	0.22	1,819	160	0.46
					OH	1,003	2,095	0.02								
P15-1	15	Capital Garden	Client	LT	UG	50										
					UG	50	6,276	0.01				5,993	1.58	5,995	160	0.47
					UG	882	6,276	0.06								
					OH	869	6,276	0.18								
P15-2	23	Asset Mid Town Poonkunnam	Client	LT	UG	151										
					UG	1,033	2,691	0.01				2,414	0.81	2,414	160	0.46
					OH	877	2,691	0.03								
RMU11	36	SAFA Tower	C/D	LT	UG	79										
					UG	961	27,504	1.31	27,113	5.52		27,113	15.02	27,128	160	0.63
					OH	877	27,504	3.41								
RMU12	38	Dhanalakshmi Bank	Client	HT	UG	10										
					UG	896	12,820	0.27								
					OH	652	12,820	0.55								
P16-1	16	Capital Village	Client	LT	UG	57										
					UG	1,257	15,015	0.51				14,223	38.59	14,262	630	1.26
					OH	718	15,015	0.83								

P16	17	Ushas	Distribution	LT	OH	38										
					UG	875	90,726	12.98	89,788	75.74		89,788	54.92	89,843	500	1.47
					OH	711	90,726	30.10								
P17	18	Palissery Tower	Distribution	LT	OH	25										
					UG	875	9,846	0.15	9,416	0.28		9,416	21.46	9,438	250	0.68
					OH	763	9,846	0.38								
P18-1	19	Kingsway	Client	LT	UG	61										
					UG	936	8,311	0.12				8,025	1.42	8,027	160	0.47
					OH	873	8,311	0.31								
P19	24	Vincent Tower	Client	LT	UG	42										
					UG	42	3,651	0.00				3,374	0.25	3,374	160	0.46
					UG	875	3,651	0.02								
					OH	944	3,651	0.06								
P19-1	20	Cheloor Appartment	Client	LT	UG	97										
					UG	97	3,212	0.00				2,933	0.19	2,933	160	0.47
					UG	875	3,212	0.02								
					OH	972	3,212	0.05								
	NET SUM							133.52		152.14			892.67			

3.14M. O ROAD FEEDER

Table 57: Loss analysis – M. O Road

Mapping details					Up to Transformer primary or HT metering				From consumer		LT cable - secondary of transformer		Transformer loss			
From Map no	Map no	Pole/transf ormer/AB	Transfo rmer owners hip	Mete ring point	Ca ble	Total dista nce	Energy transm itted	HT OH line loss	Energy transm itted	LT OH line loss	Energy at pole near transf ormer	LT Cable line loss	Trans mission at transf ormer second ary	Cap acity of DT	Transfo rmer loss	Transfo rmer loss
						m	kWh/ Month	kWh/ month	kWh/M onth	kWh/ month	kWh/mo nth	kWh/ month	kWh/ month	kVA	kW	KWh/ month
SS																
P4	49	Exhibition	Depart ment	LT	UG	15										
					UG	1,330	4,223	0.04	3,819	0	3,819	0.40	3,820	250	0.67	403
					UG	15	4,223	0.00								
AB1	11	Pathans	Client	LT	UG	74										
					UG	1,939	19,705	1.36			19,368	6.60	19,375	160	0.55	330
					UG	74	19,705	0.08								
RMU1	53	Ragam Theatre	Client	HT	UG	25										
					UG	1,939	33,399	3.90								
					UG	59	33,399	0.19								
RMU2	50	Baby Paul	Client	LT	UG	13										
					UG	1,939	7,903	0.22			7,617	1.28	7,619	160	0.47	284
					UG	61	7,903	0.01								
P5-1	17	Elite Hotel	Client	HT	UG	70										
					UG	1,939	30,859	3.33								
					UG	70	30,859	0.19								
					OH	19	30,859	0.09								
P6	10	Manshire	Client	HT	UG	11										

					UG	1,939	20,809	1.51								
					UG	11	20,809	0.01								
					OH	72	20,809	0.16								
P7-1	16	Bharath Hotel	Client	HT	UG	28										
					UG	1,939	29,260	2.99								
					UG	28	29,260	0.07								
					OH	104	29,260	0.46								
RMU3	54	White Palace	Client	HT	UG	-										
					UG	1,939	24,735	2.14								
P8-1	15	Lavish	Client	LT	UG	26										
					UG	1,965	1,125	0.00			465	0.00	465	400	1.10	660
					OH	210	1,125	0.00								
AB2	9	Store	Department	LT	UG											
					UG	1,939	75,198	19.75	74,336	52	74,336	60.23	74,397	250	1.34	801
					OH	139	75,198	4.03								
AB3	55	MK	Client	HT	UG	80										
					UG	2,019	604	0.00								
					OH	197	604	0.00								
P10-1	Tr-1	Lamex(Not marked)		LT	OH	35										
					UG	1,939	3,926	0.05			3,522	0.44	3,523	250	0.67	403
					OH	430	3,926	0.03								
RMU Fameel	Tr-Fameel	Fameel	Client	LT	UG	20										
					UG	1,959	276	0.00			-	-	-	160	0.46	276
					OH	433	276	0.00								
AB4	RMU4,8	RMU-31204, Janardhanan Complex	Department	LT	UG	4										
					UG	1,943	50,821	9.04	49,961	19	49,961	142.8	50,131	315	1.15	690
					OH	388	50,821	5.15			49,961	27.47				
AB5	1	Corporation Office	Department	LT	OH	42										

					UG	1,939	42,081	6.19	41,115	13	41,115	28.34	41,439	315	1.07	642
					OH	496	42,081	4.52			41,115	37.20				
											41,115	45.92				
											41,115	212.6				
P12	2	BSNL CTD 1	Client	HT	UG	42										
					UG	1,981	4,902	0.09								
					OH	451	4,902	0.06								
P12	3	BSNL CTD 2	Client	HT	UG	42										
					UG	1,981	36,813	4.84								
					OH	451	36,813	3.14								
P12-1	4	BSNL Pattalam Exchange	Client	HT	UG	57										
					UG	2,082	37,050	5.15								
					UG	57	37,050	0.44								
					OH	451	37,050	3.18								
P12-1	5	BSNL Pattalam Exchange	Client	HT	UG	57										
					UG	2,082	-	-								
					UG	57	-	-								
					OH	451	-	-								
P12-1	6	BSNL Pattalam Exchange	Client	HT	UG	57										
					UG	2,082	-	-								
					UG	57	-	-								
					OH	451	-	-								
RMU5	52	Jai Hind Market	Depart ment	LT	UG	228										
					UG	2,167	59,521	13.83	58,695	19	58,714	60.70	58,775	315	1.24	746
					OH	454	59,521	8.28								
AB6	13	CP Tower	Client	LT	UG	68										
					UG	2,007	1,005	0.00			465	0.01	465	315	0.90	540
					OH	358	1,005	0.00								
P14	20	Jonsons	Client	LT	UG	77										

					UG	1,999	4,049	0.06			3,769	1.83	3,771	160	0.46	278
					OH	403	4,049	0.03								
RMU6	46	Mathrubhumi	Client	HT	UG	242										
					UG	2,242	-	-								
					OH	358	-	-								
P15	21	Manappuram Hotel	Client	HT	UG	36										
					UG	2,035	11,657	0.50								
					OH	358	11,657	0.25								
	22	Manappuram Hotel	Client	LT	UG	5										
					UG	2,040	13,855	0.71			13,531	11.80	13,543	100	0.52	312
					OH	358	13,855	0.35								
P16-1	29	Kuriland	Client	LT	UG	15										
					UG	2,004	4,110	0.06			3,847	0.35	3,848	100	0.44	262
					UG	15	4,110	0.00								
					OH	379	4,110	0.03								
RMU7	45	Vattekkat Arcade	Client	LT	UG	80										
					UG	2,084	10,702	0.43			10,486	2.36	10,488	63	0.36	214
					OH	373	10,702	0.22								
P17	14	Jose Alukas	Client	HT	UG	51										
					UG	2,060	21,674	1.74								
					OH	397	21,674	0.96								
P17	31	New Manshire	Client	HT	UG	75										
					UG	2,029	16,452	0.99								
					OH	397	16,452	0.55								
RMU8	43	Sapphire Hotel	Client	HT	UG	213										
					UG	2,212	18,683	1.39								
					OH	455	18,683	0.82								
RMU9	47	TCR Fashion	Client	HT	UG											
					UG	2,212	-	-								
					UG	50	-	-								

					OH	455	-	-								
G18	26	Alukkas Seafort	Client	HT	UG	87										
					UG	2,052	15,774	0.92								
					OH	455	15,774	0.58								
P19	25	Ammus Regency	Client	HT	UG	30										
					UG	1,965	13,068	0.60								
					UG	30	13,068	0.01								
					OH	500	13,068	0.44								
P20-1	23	Lafame	Department	LT	OH	32										
					UG	1,965	38,807	5.33	38,188	11	38,199	19.57	38,283	250	0.87	524
					OH	537	38,807	4.16			38,199	64.41				
P20-2	24	Omega Paradise	Client	LT	UG	30										
					UG	1,965	4,093	0.06			3,791	0.20	3,792	200	0.50	302
					UG	30	4,093	0.00								
					OH	546	4,093	0.05								
AB8	30	Kovilakam	Client	LT	UG	37										
					UG	1,965	5,225	0.10			4,820	1.00	4,821	250	0.67	404
					UG	37	5,225	0.00								
					OH	581	5,225	0.08								
G19	27	Sagara Apartment	Client	LT	UG	65										
					UG	2,030	3,036	0.03			2,776	0.20	2,776	100	0.43	260
					OH	677	3,036	0.03								
P22	51	Pearl Dept.	Department	LT	OH	43										
					UG	1,965	37,445	4.96	36,740	10	36,750	67.94	36,818	100	1.04	627
					OH	662	37,445	4.77								
P22-1	28	Pearl Regency	Client	HT	UG	31										
					UG	1,965	21,800	1.68								
					UG	31	21,800	0.03								
					OH	668	21,800	1.63								

G24	AB9, 32	ABL-51212, Kuruppam Road 1	Department	LT	UG	44										
					UG	2,368	70,574	21.25	69,678	46	69,724	40.76	69,765	500	1.35	809
					OH	358	70,574	9.16								
G24	AB9, 33	ABL-51212, Kuruppam Road 2	Department	LT	UG	44										
					UG	2,368	38,568	6.35	37,723	9	37,732	119.37	37,852	500	1.19	717
					OH	358	38,568	2.74								
AB9	7	Jaya Palace	Client	LT	UG	15										
					UG	2,368	8,479	0.31			8,189	0.74	8,194	160	0.47	285
					UG	15	8,479	0.00			8,189	3.71				
					OH	358	8,479	0.13								
G23	34	Enark Appartment	Client	LT	UG	54										
					UG	2,378	12,189	0.64			11,634	6.89	11,641	315	0.91	548
					OH	358	12,189	0.27								
G25	19	Luciya Palace	Client	HT	UG	108										
					UG	2,475	26,347	3.10								
					OH	409	26,347	1.46								
P24	35	Nest Shopping	Client	LT	UG	25										
					UG	2,368	4,314	0.08			4,035	0.22	4,035	160	0.46	278
					UG	25	4,314	0.00								
					OH	424	4,314	0.04								
P25	36	Trade Centre1	Client	HT	UG	27										
					UG	2,368	8,834	0.33								
					UG	27	8,834	0.00								
					OH	367	8,834	0.15								
P25	37	Trade Centre 2	Client	LT	UG	27										
					UG	2,368	21,093	1.90			20,491	36.96	20,528	315	0.94	565
					UG	27	21,093	0.03								
					OH	367	21,093	0.84								

P26	38	Grand Park Hotel1	Client	HT	UG	30										
					UG	2,467	17,850	1.42								
					UG	30	17,850	0.03								
					OH	367	17,850	0.60								
P26	39	Grand Park Hotel 2	Client	HT	UG	30										
					UG	2,467	4,509	0.09								
					UG	30	4,509	0.00								
					OH	367	4,509	0.04								
RMU10	42	Hotel Garuda	Client	HT	UG	29										
					UG	2,486	43,865	8.62								
					UG	29	43,865	0.13								
					OH	367	43,865	3.63								
P29	RMU11, 44	RMU31206, TSR Dist. Cop. Bank	Client	HT	UG	30										
					UG	2,497	7,437	0.25								
					OH	401	7,437	0.11								
P31	RMU12, 6	Fridge Hosue	Client	HT	UG	30										
					UG	2,497	11,162	0.56								
					OH	496	11,162	0.32								
P33	40	Pooram Residency1	Client	HT	UG	30										
					UG	2,467	7,003	0.22								
					UG	30	7,003	0.00								
					OH	571	7,003	0.14								
P33	41	Pooram Residency 2	Client	LT	UG	30										
					UG	2,467	2,159	0.02			1,882	0.04	1,882	160	0.46	277
					UG	30	2,159	0.00								
					OH	571	2,159	0.01								
G30	12	Pathayyapura	Client	LT	UG	141										
					UG	1,939	11,367	0.45			10,685	17.59	10,702	400	1.11	665

					UG	141	11,367	0.09								
	NET SUM							204.65		178		1,019.9				13,102

3.15 DISTRICT HOSPITAL FEEDER

Table 58: Loss analysis – DH

Mapping details					Up to Transformer primary or HT metering				From consumer		LT cable – secondary of transformer		Transformer loss			
From Map no	Map no	Pole/transformer/AB	Transformer ownership	Metering point	Cable	Total distance	Energy transmitted	HT OH line loss	Energy transmitted	LT OH line loss	Energy at pole near transformer	LT Cable line loss	Transmission at transformer secondary	Capacity of DT	Transformer loss	Transformer loss
						m	kWh/Month	kWh/month	kWh/Month	kWh/month	kWh/month	kWh/month	kWh/month	kVA	kW	KWh/month
ss		Substation														
G11	ABL51602	ABL			UG	1,078										
ABL51602	37	Kerala Water Authority	Department	LT	UG	15										
					UG	1,165	71,306	10.7	70,177	20.0	70,177	328.8	70,506	500	1.3	800
RMU31601	36	Vyapari Vyavasai	Client	LT	UG	33										
					UG	33	4,665	0.0			4,261	0.3	4,261	250	0.7	403
					UG	1,179	4,665	0.0								
					OH	123	4,665	0.0								
G12	31	Good Will	Client	HT	UG	71										
					UG	1,221	16,627	0.6								
					OH	123	16,627	0.2								

AB Cheloor	1	Cheloor Golden Enclave	Client	LT	UG	71										
					UG	71	5,568	0.0			5,163	0.9	5,164	250	0.7	404
					UG	1,150	5,568	0.1								
					OH	275	5,568	0.0								
AB Cheloor	AB Fortune ,42-	Classic Fortune	Department	LT	OH	62										
					UG	1,150	11,510	0.3	11,192	0.4	11,192	1.9	11,216	100	0.5	294
					OH	337	11,510	0.2			11,192	4.3				
											11,192	17.7				
RMU Azalia	Forus Azalia	Forus Azalia	Client	LT	UG	33										
					UG	1,203	300	0.0			-	-	-	200	0.5	300
					OH	353	300	0.0								
G16	3	Menachery	Client	LT	UG	51										
					UG	1,200	3,299	0.0			3,022	0.5	3,022	160	0.5	277
					OH	319	3,299	0.0								
AB Cheloor	4	Cheloor Platinum Heights	Client	LT	UG	42										
					UG	1,191	8,095	0.1			7,551	1.1	7,552	315	0.9	543
					OH	481	8,095	0.2								
RMU31 602	41	Alfa Breeza	Client	LT	UG	31										
					UG	31	2,571	0.0			2,294	0.2	2,294	160	0.5	277
					UG	1,429	2,571	0.0								
					OH	475	2,571	0.0								
AB Navani	5	Navani	Client	LT	UG	60										
					UG	60	6,449	0.0			6,141	3.6	6,145	200	0.5	304
					UG	1,150	6,449	0.1								
					OH	531	6,449	0.1								
P17	AB CSB, 6-CSB	CSB	Department	LT	OH	11										
					UG	1,150	52,881	5.8	52,220	20.5	52,220	45.7	52,265	250	1.0	616

					OH	651	52,881	9.4								
AB Skyline	9	Sky line	Client	LT	UG	67										
					UG	67	8,445	0.0			8,036	2.0	8,038	250	0.7	407
					UG	1,239	8,445	0.2								
					OH	791	8,445	0.3								
AB Lalitha	10	Lalitha Heights	Client	LT	UG	31										
					UG	31	2,940	0.0			2,680	0.2	2,680	100	0.4	260
					UG	1,239	2,940	0.0								
					OH	855	2,940	0.0								
RMU st. Thomas	St. Thomas	St. Thomas	Client	HT	UG	24										
					UG	1,186	10,588	0.2								
					OH	807	10,588	0.5								
AB CSB	32- CSB	CSB	Client	HT	UG	45										
					UG	45	-	-								
					UG	1,176	-	-								
					OH	856	-	-								
AB Navani	8	Navani	Client	LT	UG	151										
					UG	151	4,391	0.0			4,088	1.6	4,090	200	0.5	302
					UG	1,176	4,391	0.0								
					OH	945	4,391	0.1								
AB St.mary's	7	St. Mary's College	Client	HT	UG	31										
					UG	31	19,237	0.0								
					UG	1,176	19,237	0.8								
					OH	1,032	19,237	2.0								
RMU31 603	11	DH College Road	Department	LT	UG	13										
					UG	1,278	89,329	18.4	86,988	71.1	86,988	1,370.3	88,358	315	1.6	971
					OH	1,001	89,329	41.1								
RMU31 603	39	DH Solar	Department	LT	UG	13										

RMU31 605	12	Dt.HS Palakkal	Depart ment	LT	UG	4											
					UG	1,411	15,465	0.6	14,905	0.7	14,905	7.5	14,912	315	0.9	552	
					OH	1,001	15,465	1.2									
RMU31 605	13	Dt.HS Palakkal	Depart ment	LT	UG	6											
					UG	1,413	37,961	3.7	37,280	7.8	37,280	58.3	37,338	315	1.0	623	
					OH	1,001	37,961	7.4									
RMU31 604	35- Josco	Josco	Client	HT	UG	57											
					UG	1,461	15,802	0.7									
					OH	1,001	15,802	1.3									
RMU31 606	40- DH	DH	Client	HT	UG	102											
					UG	1,646	1,04,418	32.3									
					OH	1,010	1,04,418	56.6									
RMU31 607	19-	Chemman ur cooperative Office	Client	HT	UG	195											
					UG	1,622	23,771	1.7									
					OH	1,001	23,771	2.9									
AB SIB	18- SIB	SIB	Client	HT	UG	198											
					UG	198	4,539	0.0									
					UG	1,404	4,539	0.1									
					OH	1,001	4,539	0.1									
ABL516 07	15	8 Pole 2	Depart ment	LT	OH	8											
ABL516 07	16	8 Pole 3	Depart ment	LT	OH	4											
ABL516 07	14 ABL516 08	8 Pole 1	Depart ment	LT	OH	2											
					UG	1,475	1,027	0.0	625	-	625	0.0	625	250	0.7	402	
					OH	1,003	1,027	0.0									

ABL51607	17	8 Pole 4	Department	LT	OH	2										
					UG	1,475	17,793	0.8	17,423	-	17,423	49.6	17,473	160	0.5	320
					OH	1,003	17,793	1.6								
G51	AB fashion, 21-	Fashion Fabrics	Department	LT	UG	374										
					UG	1,848	56,624	10.7	54,908	-	54,908	637.0	55,876	315	1.2	747
					OH	1,003	56,624	16.5			54,908	331.8				
AB Elite	20-	Elite Saree	Client	HT	UG	34										
					UG	1,882	13,102	0.6								
					OH	1,008	13,102	0.9								
G27	P31, 22-	Ariyagadi	Department	LT	UG	189										
					UG	1,594	60,808	10.6	60,013	-	60,013	126.8	60,139	250	1.1	668
					OH	1,001	60,808	19.0								
G36	P39, 23 ABL516 12	Kuttans, ABL	Department	LT	UG	299										
					UG	1,893	55,298	10.4	54,530	24.2	54,530	153.9	54,684	250	1.0	615
					OH	1,001	55,298	15.7								
G37	RMU31 609, 34	Holy Space Shopping Complex	Client	LT	UG	54										
					UG	1,947	19,419	1.3			18,895	95.9	18,991	250	0.7	428
					OH	1,001	19,419	1.9								
AB holy ht	24	Holy Heights	Client	LT	UG	141										
					UG	2,034	9,167	0.3			8,503	1.4	8,504	400	1.1	663
					OH	1,001	9,167	0.4								
P40	25	Erinjeri Ariyangadi 2	Department	LT	OH	50										
					UG	1,989	57,032	11.7	56,335	-	56,335	69.2	56,404	250	1.0	628
					OH	1,051	57,032	17.6								
G44	ABL516 13, 26	High Road	Department	LT	UG	177										

					UG	2,166	51,383	10.3	50,687	-	50,687	107.7	50,795	250	1.0	588
					OH	1,001	51,383	13.6								
LBS	29	CT Plaza	Client	LT	UG	44										
					UG	44	799	0.0			523	0.0	523	160	0.5	276
					UG	1,608	799	0.0								
					OH	1,297	799	0.0								
AB east	27	East end plaza	Client	LT	UG	71										
					UG	1,664	4,970	0.1			4,689	1.9	4,691	160	0.5	279
					OH	1,313	4,970	0.2								
AB adam	28	Adam bazar	Client	LT	UG	99										
					UG	1,693	9,422	0.3			8,871	6.4	8,877	315	0.9	545
					OH	1,381	9,422	0.6								
AB Sadana n	33-	Sadanadha n	Client	LT	UG	52										
					UG	1,646	12,249	0.4			11,933	1.9	11,935	200	0.5	314
					OH	1,397	12,249	1.1								
AB Park land	30-	Park Land	Client	LT	UG	58										
					UG	58	3,781	0.0			3,504	0.1	3,504	160	0.5	278
					UG	1,594	3,781	0.0								
					OH	1,465	3,781	0.1								
G32	RMU31 608, 38-	Shalimar Shopping Complex	C/D	LT	UG	96										
					UG	1,690	19,363	1.1	18,895	-	18,895	14.6	18,934	250	0.7	429
					OH	1,455	19,363	2.8			18,895	0.6				
											18,895	23.6				
	NET SUM							350.9		144.8		3,467.3				14,514

3.16 VANCHIKULAM FEEDER

Table 59: Loss analysis – Vanchikulam

Mapping details					Up to Transformer primary or HT metering				From consumer		LT cable - secondary of transformer		Transformer loss			
From Map no	Map no	Pole/transfo rmer/AB	Tran sform er own ership	Met ering point	Ca ble	Total dista nce	Energy transm itted	HT OH line loss	Energy transm itted	LT OH line loss	Energy at pole near transfo rmer	LT Cable line loss	Transmi ssion at transfo rmer seconda ry	Capa city of DT	Transfo rmer loss	Transfo rmer loss
						m	kWh/ Month	kWh/ month	kWh/M onth	kWh/ month	kWh/mo nth	kWh /month	kWh/m onth	kVA	kW	KWh/ month
	S-S	Substation feeder														
S-S	2P	Post			UG	21										
P7	P8	Post			OH	239										
P8	1	-Raya Complex	Depart ment	LT	OH	7										
					UG	722	32,962	0.98	32,371	2.07	32,371	20	32,485	250	0.79	477
					OH	1,671	32,962	4.37			32,371	94				
					OH	247	32,962	0.96								
P9	2-	Shankaraiyar Road	Depart ment	LT	OH	152										
					UG	722	56,032	2.84	54,259	17.44	54,259	58	54,386	250	2.74	1,645
					OH	1,671	56,032	12.62			54,259	69				
					OH	398	56,032	4.47								
ABL51806	3, 4-Modern	Transformer	Client	LT,H T	UG	30										
					UG	751	22,698	0.48			15,595	19	22,255	250	0.74	443
					OH	1,671	22,698	2.07								
					OH	567	22,698	1.04								
RMU31802	11-	WestPlaza	Client	HT	UG	61										
					UG	783	4,958	0.02								

					OH	1,671	4,958	0.10								
					OH	603	4,958	0.05								
P10	8, 7-	Grand mall	Client	LT,H T	UG	44										
					UG	766	47,632	2.17			10,173	1	46,968	315	1.11	663
					OH	1,671	47,632	9.12								
					OH	629	47,632	5.10								
AB Maruthi	9- Bhuvvari Tower	Transformer	Client	HT	UG	40										
					UG	840	3,280	0.01								
					OH	1,671	3,280	0.04								
					OH	645	3,280	0.02								
G2	AB Maruthi , 10-	Maruthi Apartment	Depar tment	LT	UG	72										
					UG	800	56,103	3.15	55,191	14.43	55,191	53	55,347	500	1.26	756
					OH	1,671	56,103	12.66			55,191	102				
					OH	645	56,103	7.25								
RMU31 801	6-K K Tower	Transformer	Client	HT	UG	144										
					UG	865	7,814	0.07								
					OH	1,671	7,814	0.25								
					OH	645	7,814	0.14								
AB Salfloa	5- Salfloa	Transformer	Client	HT	UG	21										
					UG	21	11,320	0.00								
					UG	722	11,320	0.12								
					OH	1,671	11,320	0.52								
					OH	705	11,320	0.32								
P13	14- Fimat	Transformer	Depar tment	LT	OH	13										
					UG	722	3,953	0.01	3,690	0.03	3,690	1	3,691	100	0.44	262
					OH	1,671	3,953	0.06								
					OH	696	3,953	0.04								
RMU31 803	12, 13	Sunny Diamonds	Client	LT,H T	UG	20										

					UG	742	57,753	3.09			56,878	92	56,970	400	1.31	783
					OH	1,671	57,753	13.41								
					OH	696	57,753	8.30								
P13-1	15-Hawa	Transformer	Department	LT	OH	24										
					UG	722	37,702	1.28	37,125	6.53	37,125	11	37,201	250	0.83	501
					OH	1,671	37,702	5.71			37,125	29				
					OH	843	37,702	4.28			37,125	36				
RMU31804	16-Fathima	Transformer	Client	HT	UG	46										
					UG	768	8,472	0.07								
					OH	1,671	8,472	0.29								
					OH	871	8,472	0.22								
AB Bhavani	17-Bhavani	Transformer	Client	LT	UG	33										
					UG	33	11,006	0.01			10,458	2	10,460	315	0.91	546
					UG	873	11,006	0.13								
					OH	1,671	11,006	0.49								
					OH	964	11,006	0.42								
AB Sudharsan	18-	Sudharsan	Client	LT	UG	34										
					UG	34	6,844	0.00			6,561	1	6,562	160	0.47	282
					UG	722	6,844	0.04								
					OH	1,671	6,844	0.19								
					OH	998	6,844	0.17								
AB Commercial	19-Commercial	Transformer	Client	HT	UG	35										
					UG	35	6,791	0.00								
					UG	722	6,791	0.04								
					OH	1,671	6,791	0.19								
					OH	1,043	6,791	0.17								
RMU TBPL	TBPL RIO	Transformer	Client	LT	UG	54										
					UG	776	660	0.00			-	-	-	400	1.10	660

					OH	1,671	660	0.00								
					OH	1,098	660	0.00								
P16	20-	Kaveri Apartment	Department	LT	OH	153										
					UG	722	46,776	1.98	45,857	12.46	45,869	88	45,945	250	1.38	831
					OH	1,671	46,776	8.80								
					OH	1,186	46,776	9.27								
RMU31 805	22- Level10	Transformer	Client	HT	UG	33										
					UG	33	9,160	0.00								
					UG	722	9,160	0.08								
					OH	1,671	9,160	0.34								
					OH	902	9,160	0.27								
AB Art	21-Art of living	Transformer	Client	LT	UG	45										
					UG	45	2,471	0.00			2,211	0	2,211	100	0.43	259
					UG	722	2,471	0.01								
					OH	1,671	2,471	0.02								
					OH	980	2,471	0.02								
ABL518 10	23-	Refrigeration	Department	LT	OH	68										
					UG	722	72,641	4.77	71,379	30.18	71,379	172	71,551	500	1.82	1,090
					OH	1,671	72,641	21.22								
					OH	1,034	72,641	19.50								
P17	24- Sainic Gas	Transformer	C/D	LT	OH	57										
					UG	722	1,815	0.00	1,412	0.00	1,412	0	1,412	250	0.67	402
					OH	1,728	1,815	0.01			1,412	1				
					OH	1,060	1,815	0.01								
AB LIC	25-LIC	Transformer	Client	LT	UG	50										
					UG	50	2,638	0.00			2,361	0	2,361	160	0.46	277
					UG	726	2,638	0.01								
					OH	1,671	2,638	0.03								
					OH	1,169	2,638	0.03								

P18	RMU31 806, 26-	RMU, South Plaza	Client	LT	UG	14										
					UG	722	30,889	0.86			30,386	32	30,419	250	0.78	470
					OH	1,671	30,889	3.84								
					OH	1,169	30,889	3.99								
G5	27-	Sitharam Heritage	C/D	LT	UG	300										
					UG	310	36,083	0.82	35,200	5.87	35,200	7	35,591	250	0.82	492
					UG	722	36,083	1.18			35,200	19				
					OH	1,671	36,083	5.23			35,200	365				
					OH	1,342	36,083	6.24								
P19	RMU31 807, 28	KMJ	C/D	LT	UG	27										
					UG	722	525	0.00	123	0.00	123	0	123	250	0.67	402
					OH	1,671	525	0.00			123	0				
					OH	1,342	525	0.00								
AB Merlin	29-	Merlin Hotel	Client	HT	UG	98										
					UG	98	19,729	0.10								
					UG	722	19,729	0.35								
					OH	1,671	19,729	1.56								
					OH	1,377	19,729	1.92								
P21	P22, 31-	State Hotel	Depart ment	LT	OH	109										
					UG	722	27,418	0.68	26,964	2.87	26,964	-	26,964	250	0.76	454
					OH	1,671	27,418	3.02								
					OH	1,476	27,418	3.96								
G6	30-	Global Plaza	C/D	LT	UG	105										
					UG	833	15,972	0.27	15,361	0.93	15,361	1	15,418	315	0.92	554
					OH	1,671	15,972	1.03			15,361	56				
					OH	1,476	15,972	1.35								
G7	32	-Love shore	Client	HT	UG	104										
					UG	832	27,934	0.81								
					OH	1,671	27,934	3.14								
					OH	1,476	27,934	4.12								

	NET SUM							220.38		92.82		1,33 1				12,249
--	--------------------	--	--	--	--	--	--	---------------	--	--------------	--	-------------------	--	--	--	---------------

TECHNICAL LOSSES - SUMMARY

The technical losses comprising all the section above is estimated in feeder wise and given in the following tables.

➤ Mission Quarters feeder

Table 60: T & D loss summary – Mission Quarters feeder

Particulars	Units	Percentage
	kWh/annum	%
Net energy sales - annual	94,04,933	88.75
LT Overhead line loss	9,85,420	9.30
LT Cable loss	17,288	0.16
Transformer Loss	1,87,186	1.77
HT overhead & cable line loss	2,851	0.03
Total loss	11,92,745	11.25
Estimated Consumption at feeder level	1,05,97,678	100
Registered consumption at feeder level meter	1,02,68,000	

➤ Veleyanoor feeder

Table 61: T & D loss – Veleyanoor feeder

Particulars	Units	Percentage
	kWh/annum	%
Net energy sales - annual	74,63,821	90.22
LT Overhead line loss	6,85,157	8.28
LT Cable loss	14,940	0.18
Transformer Loss	1,07,590	1.30
HT overhead & cable line loss	1,577	0.02
Total loss	8,09,264	9.78
Estimated Consumption at feeder level	82,73,085	100
Registered consumption at feeder level meter	92,29,000	

➤ Koorkenchery feeder

Table 62: T & D loss Koorkenchery feeder

Particulars	Units	Percentage
	kWh/annum	%
Net energy sales - annual	97,31,425	83.65
LT Overhead line loss	17,20,936	14.79
LT Cable loss	34,831	0.30

Transformer Loss	1,41,364	1.22
HT overhead & cable line loss	4,946	0.04
Total loss	19,02,077	16.35
Estimated Consumption at feeder level	1,16,33,502	100
Registered consumption at feeder level meter	97,62,000	

➤ **Paravattany feeder**

Table 63: T & D loss Summary – Paravattany feeder

Particulars	Units	Percentage
	kWh/annum	%
Net energy sales - annual	83,06,391	85.56
LT Overhead line loss	11,99,830	12.36
LT Cable loss	45,111	0.46
Transformer Loss	1,51,683	1.56
HT overhead & cable line loss	5,577	0.06
Total loss	14,02,201	14.44
Estimated Consumption at feeder level	97,08,592	100.00
Registered consumption at feeder level meter	1,21,47,000	

➤ **Jubilee Mission feeder**

Table 64: T & D loss summary – JMC feeder

Particulars	Units	Percentage
	kWh/annum	%
Net energy sales - annual	89,35,392	99.95
LT Overhead line loss	-	0.00
LT Cable loss	-	0.00
Transformer Loss	-	0.00
HT overhead & cable line loss	4,139	0.05
Total loss	4,139	0.05
Estimated Consumption at feeder level	89,39,531	100
Registered consumption at feeder level meter	89,93,700	

➤ **Vivekodhayam feeder**

Table 65: T & D loss Summary – Vivekodhayam feeder

Particulars	Units	Percentage
	kWh/annum	%
Net energy sales - annual	73,05,102	88.96
LT Overhead line loss	7,72,543	9.41

LT Cable loss	23,510	0.29
Transformer Loss	1,08,868	1.33
HT overhead & cable line loss	1,822	0.02
Total loss	9,06,743	11.04
Estimated Consumption at feeder level	82,11,845	100
Registered consumption at feeder level meter	84,10,800	

➤ **Bini feeder**

Table 66: T & D loss summary – Bini feeder

Particulars	Units	Percentage
	kWh/annum	%
Net energy sales - annual	57,18,342	95.72
LT Overhead line loss	1,57,048	2.63
LT Cable loss	2,746	0.05
Transformer Loss	94,811	1.59
HT overhead & cable line loss	854	0.01
Total loss	2,55,459	4.28
Estimated Consumption at feeder level	59,73,801	100
Registered consumption at feeder level meter	56,56,000	

➤ **Poonkunam feeder**

Table 67: T & D loss Summary – Poonkunam feeder

Particulars	Units	Percentage
	kWh/annum	%
Net energy sales - annual	77,53,356	99.82
LT Overhead line loss	152	0.00
LT Cable loss	893	0.01
Transformer Loss	13,090	0.17
HT overhead & cable line loss	134	0.00
Total loss	14,269	0.18
Estimated Consumption at feeder level	77,67,625	100
Registered consumption at feeder level meter	1,87,81,200	

➤ **Keralavarma feeder**

Table 68: T & D loss – Keralavarma feeder

Particulars	Units	Percentage
	kWh/annum	%

Net energy sales - annual	1,00,65,116	88.85
LT Overhead line loss	10,08,743	8.90
LT Cable loss	31,042	0.27
Transformer Loss	2,15,513	1.90
HT overhead & cable line loss	7,714	0.07
Total loss	12,63,012	11.15
Estimated Consumption at feeder level	1,13,28,128	100
Registered consumption at feeder level meter	1,02,96,400	

➤ **Ramanilayam feeder**

Table 69: T & D loss Summary – Ramanilayam feeder

Particulars	Units	Percentage
	kWh/annum	%
Net energy sales - annual	72,10,945	95.94
LT Overhead line loss	2,02,394	2.69
LT Cable loss	7,204	0.10
Transformer Loss	94,011	1.25
HT overhead & cable line loss	1,770	0.02
Total loss	3,05,380	4.06
Estimated Consumption at feeder level	75,16,325	100
Registered consumption at feeder level meter	1,07,22,000	

➤ **M.O Road feeder**

Table 70: T & D loss – M.O Road feeder

Particulars	Units	Percentage
	kWh/annum	%
Net energy sales - annual	1,14,53,015	98.50
LT Overhead line loss	2,142	0.02
LT Cable loss	12,239	0.11
Transformer Loss	1,57,220	1.35
HT overhead & cable line loss	2,456	0.02
Total loss	1,74,056	1.50
Estimated Consumption at feeder level	1,16,27,071	100
Registered consumption at feeder level meter	1,33,30,000	

➤ **Chembukavu feeder**

Table 71: T & D loss – Chembukavu feeder

Particulars	Units	Percentage
	kWh/annum	%
Net energy sales - annual	1,02,17,614	89.67
LT Overhead line loss	10,09,261	8.86
LT Cable loss	25,415	0.22
Transformer Loss	1,37,462	1.21
HT overhead & cable line loss	4,838	0.04
Total loss	11,76,975	10.33
Estimated Consumption at feeder level	1,13,94,589	100
Registered consumption at feeder level meter	49,78,000	

➤ **Shornur road feeder**

Table 72: T & D loss – Shornur road feeder

Particulars	Units	Percentage
	kWh/annum	%
Net energy sales - annual	1,12,16,068	94.35
LT Overhead line loss	4,20,859	3.54
LT Cable loss	35,046	0.29
Transformer Loss	2,13,719	1.80
HT overhead & cable line loss	2,475	0.02
Total loss	6,72,099	5.65
Estimated Consumption at feeder level	1,18,88,167	100
Registered consumption at feeder level meter	1,24,04,000	

➤ **District Hospital feeder**

Table 73: T & D loss – District Hospital feeder

Particulars	Units	Percentage
	kWh/annum	%
Net energy sales - annual	1,13,26,519	98.08
LT Overhead line loss	1,737	0.02
LT Cable loss	41,607	0.36
Transformer Loss	1,74,163	1.51
HT overhead & cable line loss	4,211	0.04
Total loss	2,21,719	1.92
Estimated Consumption at feeder level	1,15,48,238	100
Registered consumption at feeder level meter	1,13,97,000	

➤ **East Fort feeder**

Table 74: T & D loss – Eastfort feeder

Particulars	Units	Percentage
	kWh/annum	%
Net energy sales – annual	1,21,05,236	87.21
LT Overhead line loss	15,41,177	11.10
LT Cable loss	36,350	0.26
Transformer Loss	1,91,480	1.38
HT overhead & cable line loss	6,470	0.05
Total loss	17,75,478	12.79
Estimated Consumption at feeder level	1,38,80,714	100
Registered consumption at feeder level meter	1,31,60,000	

➤ **Vanchikulam feeder**

Table 75: T & D loss – Vanchikulam feeder

Particulars	Units	Percentage
	kWh/annum	%
Net energy sales – annual	78,77,406	97.93
LT Overhead line loss	1,114	0.01
LT Cable loss	15,966	0.20
Transformer Loss	1,46,992	1.83
HT overhead & cable line loss	2,645	0.03
Total loss	1,66,716	2.07
Estimated Consumption at feeder level	80,44,122	100
Registered consumption at feeder level meter	91,56,000	

- **The variation or high mismatch in the actual feeder meter reading and the calculated reading through the loss analysis, is due to the back feeding among the feeders during the power failures or maintenance.**
- During energy audit period, auditors attempted to verify the error in the meters by analysing the feeder meters at the substation using the power quality analysers and hereby summarised in commercial losses section.

4. HT/LT RATIO

The total length of the LT line from the transformer to the consumer end at the period of audit is 287.953 km. However, the separation of OH and UG among the LT side is still in the process for the RDSS implementation.

The total 11kV HT line length from the switching station to the DT or HT consumers are 117.278 km. Among this, HT OH line length shares the most with 43.29 km, UG cable with 73.98 km and ABC with 1.85 km

HT/LT ratio is the total distance of HT line to the LT lines in a system. The HT/LT ratio has calculated with respect to the total LT line where;

HT:LT = 1: 2.335, registered during the FY 2023-24, which is higher than the recommended level of 1:1.

5. SUBSIDY COMPUTATION AND ANALYSIS

The DISCOM did not received subsidy from any government or government institutions on any category during the FY 2023-24.

6. TREND ANALYSIS

The historical energy accounts/loss of the TCED DISCOM is tabulated below.

Table 76: Historical energy accounts/loss of the DISCOM

Particulars	1. T&D Losses analysis for 2021-22				2. T&D Losses analysis for 2022-23			
	Input energy (MU)	Total Billed energy (MU)	Total energy Loss (MU)	T&D losses %	Input energy (MU)	Total Billed energy (MU)	Total energy Loss (MU)	T&D losses %
DISCOM - TCED	137.59	129.05	8.54	6.21	159.665	148.36	11.305	7.08

The graphical representation of the losses for the four years (including audit period FY 2023-24) is given in the figure below.

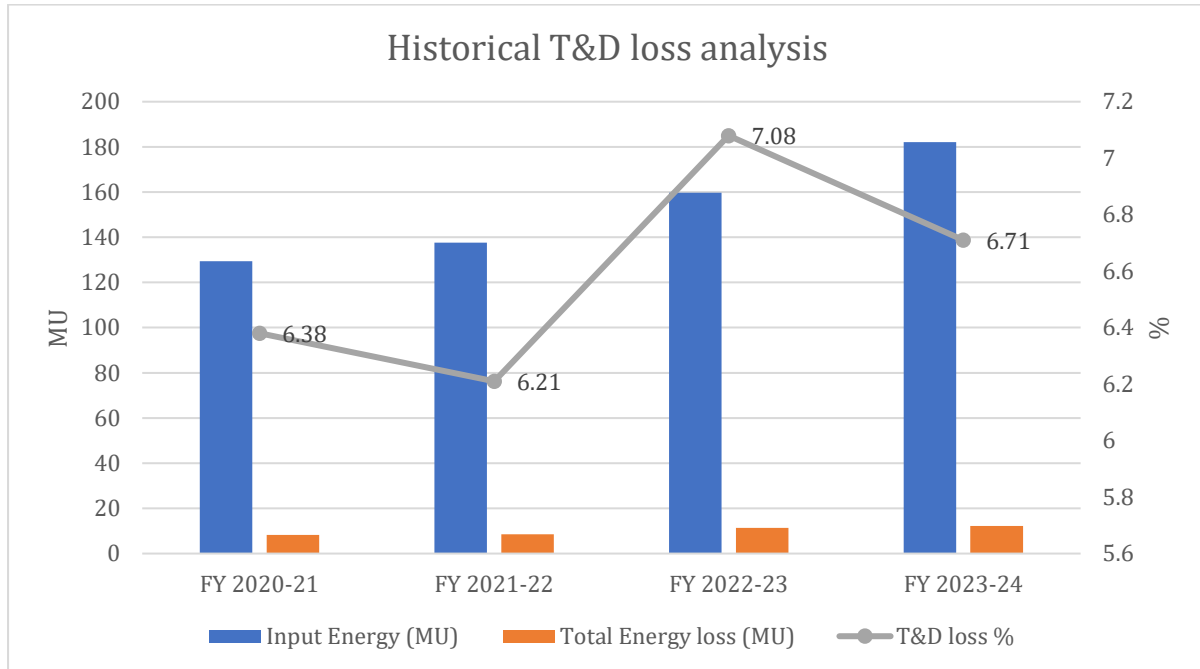

Figure 24: Historical T & D loss with audited data

- The T&D loss % shows a decrease from FY 2022-23 to FY 2023-24.

ENERGY AUDIT FINDINGS

1 COMPLIANCE TO BEE REGULATIONS

The compliance status of DISCOM to various provisions of BEE Regulations 2021 is analysed and presented below.

Clause No	Clause Details	Subclause Details	Present Status	Action plan/ comments by DISCOM
3	Intervals of time for conduct of annual energy audit	a. Conducted an annual energy audit for every financial year and submitted the annual energy audit report to the Bureau and respective State Designated Agency and also made available on the website of the electricity distribution company within a period of four months from the expiry of the relevant financial year	a. Annual energy audit for last 3 years being conducted. Report will be submitted to BEE and SDA. Report will also be uploaded onto TCED website.	
4	Intervals of time for conduct of periodic energy accounting	a. All feeder wise, circle wise and division wise periodic energy accounting is conducted by the energy manager of the electricity distribution company for each quarter of the financial year.	a. Periodic energy accounting for all quarters of FY 23-24 have been prepared by the DC and submitted.	
		b. Submitted the periodic energy accounting report to the Bureau and respective State Designated Agency and also made available on the website of electricity distribution company within forty-five days from the date of the periodic energy accounting.	b. Periodic energy accounting for all quarters of FY 23-24 have been prepared by the DC and submitted through mail.	
		c. Electricity distribution company conducted its first periodic energy accounting, for the last quarter of the financial year immediately preceding the date of such commencement (i.e. 15 th May 2024).	c. DC has submitted its first periodic energy accounting for Q4.	
		d. Electricity distribution company conducted its subsequent periodic energy accounting for each quarter of the financial year for a period of two financial years from the date of such commencement, and submit the periodic energy accounting report	d. The DC used to submit the periodic energy auditing reports as per the Energy Audit regulations.	

Clause No	Clause Details	Subclause Details	Present Status	Action plan/ comments by DISCOM
		within sixty days from the date of periodic energy accounting		
5	Pre-requisites for annual energy audit and periodic energy accounting	a. Identification and mapping of all of the electrical network assets	a. Mapping of HT line and transformers conducted by the AEA and LT lines are getting mapped by the DISCOM.	The mapping of all the assets such as transformer, pole and consumer meters will be completed by June 2025.
		b. Identification and mapping of high tension and low-tension consumers	b. All the HT consumers have been mapped by AEA and the LT consumers will be mapped by DISCOM	The mapping of LT consumers will be completed by June 2025
		c. Development and implementation of information technology enabled energy accounting and audit system, including associated software.	c. DC has LECTOREN software which does only the billing one as per the consumption input.	DC is planning to implement the software as along with the RDSS implementation of the smart meter.
		d. Electricity distribution company ensures the installation of functional meters for all consumers, transformers and feeders. Meter installation is done in a phased manner within a period of three financial years from the date of the commencement of these regulations in accordance with the trajectory set out in the First Schedule	d. All 11kV feeders have been metered. All consumers have been metered under the DISCOM. As of audit period (11 th August 2024) out of total 480 distribution transformers, 286 have been metered.	Rest of the DT meters will be completed along with the RDSS scheme June 2025.
		d1. 100% Communicable Feeder Metering integrated with AMI, by 31st December 2022 along with replacement of existing non- communicable feeder meters.	d.1. 100% of the feeders are having DLMS (Device Language Message Specification Communicable Meters).	
		d2. All Distribution Transformers (other than HVDS DT up to 25kVA and other DTs below 25 kVA) shall be metered with communicable meters. Communicable DT Metering for the following areas/ consumers to be	d.2. 59.50% of the DTs are provided with communicable meter as on 12 th August 2024.	Balance will be completed by the end of financial year 2024-25 as per the RDSS progress report.

		completed by December 2023 and in balance areas by December 2025: 100% Communicable Feeder Metering integrated with AMI, by 31st December 2022 along with replacement of existing non-communicable feeder meters.		
Clause No	Clause Details	Subclause Details	Present Status	Action plan/ comments by DISCOM
		d.2.1. All Electricity Divisions of 500 AMRUT cities, with AT&C Losses > 15%	d.2.1. Not Relevant for DC.	
		d.2.2. All Union Territories (for areas with technical difficulty, non-communicable meters may be installed)	d.2.2. Not Relevant for DC	
		d.2.3. All Industrial and Commercial consumers	d.2.3. 100% of the DTR meters is installed in the DISCOM	
		d.2.4. All Government offices at Block level and above	D2.4. DC installed 90% of the government offices at block level with communicable meter.	Plans to do the remaining installations in phased manner
		d.2.5. Other high loss areas i.e. rural areas with losses more than 25% and urban areas with losses more than 15%	d.2.5. The whole DISCOM comes under the Urban area and thus not relevant for DC.	
		d.3. Prepaid Smart Consumer Metering to be completed for all directly connected meters and AMR in case of other meters, by December 2023 in the following areas:		
		d.3.1. All Electricity Divisions of 500 AMRUT cities, with AT&C Losses > 15%;	d.3.1. Not applicable as AT&C loss is less than 15%.	
		d.3.2. All Union Territories (for areas with technical difficulty, prepaid meters to be installed);	d.3.2. Not Relevant for DC.	

Clause No	Clause Details	Subclause Details	Present Status	Action plan/ comments by DISCOM												
		d.3.3. All Industrial and Commercial consumers;	d.3.3. DC has installed 133 communicable metering-AMI for HT consumers and 18155 meters in LT, industrial and commercial.	Plans to do the work in phased manner along with RDSS by June 2024.												
		d.3.4. All Government offices at Block level and above;	d.3.4. DC installed 90% of the government offices at block level with communicable meter.	Plans to do the work in phased manner along with RDSS by June 2024.												
		d.3.5. Other high loss areas i.e. rural areas with losses more than 25% and urban areas with losses more than 15%.	d.3.5. Not applicable as T&D loss is less than 15%													
		d4. Consumer Metering: 98% by FY 2022-23 99% by FY 2023-24	d4. 100% of the consumers are metered.													
		d.5. Targets for functional meters. <table border="1" data-bbox="645 802 1108 914"> <thead> <tr> <th>Meter</th> <th>FY 22-23</th> <th>FY 23-24</th> <th>FY24-25</th> </tr> </thead> <tbody> <tr> <td>Feeder metering</td> <td>98.5%</td> <td>99.5%</td> <td>99.5%</td> </tr> <tr> <td>DT metering</td> <td>90%</td> <td>95%</td> <td>98%</td> </tr> </tbody> </table>	Meter	FY 22-23	FY 23-24	FY24-25	Feeder metering	98.5%	99.5%	99.5%	DT metering	90%	95%	98%	d5. 100% of the feeders are metered. 95% of the DT are metered. 100% of the consumers are metered.	DT metering will complete by FY 2024-25 along with RDSS scheme.
Meter	FY 22-23	FY 23-24	FY24-25													
Feeder metering	98.5%	99.5%	99.5%													
DT metering	90%	95%	98%													
		e. e1. All distribution transformers (other than high voltage distribution system up to 25kVA and other distribution system below 25 kVA) is metered with communicable meters.	e.1. DC yet to start the work	DT metering will start in phased manner.												
		e.2.And existing non-communicable distribution transformer meters is replaced with communicable meters and integrated with advanced metering infrastructure.	e.2. Yet to start the work	DT metering will start in phased manner along with RDSS smart meter installation scheme.												
		e. Electricity distribution company has established an information technology	f. Yet to start the work	After the implementation of RDSS scheme, the												

		enabled system to create energy accounting reports without any manual interference and such systems may be within a period of three years from the date of the commencement of these regulations in case of urban and priority area consumers; and within five years from the date of the commencement of these regulations in case of rural consumers		information technology enabled system will be integrated to it.
Clause No	Clause Details	Subclause Details	Present Status	Action plan/ comments by DISCOM
		g. Electricity distribution company has a centralized energy accounting and audit cell comprising of— (i) a nodal officer, an energy manager and an information technology manager, having professional experience of not less than five years; and (ii) a financial manager having professional experience of not less than five years	g. DISCOM has energy audit cell. List is mentioned in the audit report. Certified energy auditor is present for the DISCOM.	
6	Reporting requirements for annual energy audit and periodic energy accounting	a. Electricity distribution company has a nodal officer, who is a full-time employee of the electricity distribution company in the rank of the Chief Engineer or above, for the purpose of reporting of the annual energy audit and periodic energy accounting and communicate the same to the Bureau.	a. The DC is complying with this requirement	
Clause No	Clause Details	Subclause Details	Present Status	Action plan/ comments by DISCOM

		b. Electricity distribution company ensures that the energy accounting data is generated from a metering system or till such time the metering system is not in place, by an agreed method of assumption as may be prescribed by the State Commission.	b. DC has already had an agreed system of energy accounting as prescribed by the state commission. Yet to implement the system from metering values.	The completion of the energy accounting data will be generated from the metering system by the FY 2024-25.
		c. Metering of distribution transformers at High Voltage Distribution System up to 25KVA is done on cluster meter installed by the electricity distribution company	c. Not applicable	
		d. The energy accounting and audit system and software is developed to create monthly, quarterly and yearly energy accounting reports.	d. The DC is yet implement the same.	Will be completed along with the implementation of RDSS scheme by June 2025.
		e. Electricity distribution company has provided the details of the information technology system in place as specified in clause (f) of regulation 5 that ensures minimal manual intervention in creating the energy accounting reports and any manual intervention of any nature, in respect of the period specified therein, shall be clearly indicated in the periodic energy accounting report	e. The DC is yet to implement the same	Will be completed along with the implementation of RDSS scheme by June 2025.

2 NOTES OF THE EA/EM ALONG WITH QUERIES AND REPLIES TO DATA GAPS

The following tables shows the query by AEA, the response from EA of DISCOM and Notes by AEA.

Table 77: Queries and replies to data gaps

Sl no	Query by EA	Response by EA of DISCOM	Notes by AEA
1	Why the contract demand not mentioned in the bill?	Can access unlimited demand as per the agreement signed between KSEBL and Thrissur municipality on 1949.	According to that present registered maximum demand is considered for the audit.
2	Expected completion date for LT line mapping and assets?	As per the action plan to RDSS, expected time of completion is June 2025.	AEA started mapping the HT line and transformer and covered 85% of the Total DT, 88.8% of the total 11 KV feeders & 79.7% of the total consumers
3	When we analysed the loss of 16 feeder, variation observed in the unit sales. Found that very lower than the feeder meter. Any issue in feeder metering?	<p>There is no issue in feeder metering.</p> <p>The difference is due to the back feeding the supply to certain number of consumers in a particular feeder, through interlink poles.</p> <p>For eg: Bini feeder have the option for back feed from Ramanilayam, Vivekodayam and MO road feeders.</p> <p>Back fed unit data not accounted properly in the substation as there is no boundary meter to account the same.</p>	Such that, we have analysed actual loss among the feeder rather than basing on the feeder meter.
4	Why is there observed duplication of solar generation data for both LT and HT?	It was due to the software mistake. TCED will correct the same	Duplication of the solar export data is being corrected and rectified.

Sl no	Query by EA	Response by EA of DISCOM	Notes by AEA
5	The KSEBL energy meter and the TCED feeder-wise energy meter readings are not matching. An error has been observed. However, when we checked the TOD meter by bypassing the Potential Transformer (PT) and Current Transformer (CT), the values were observed to match. Why?	It is due to the error in CT ratio. Current transformer (CT) is not calibrated for last ten years.	Calibrate the current transformers (CTs) and if required replace it with new one.

CONCLUSION AND ACTION PLANS

1 CRITICAL COMMENTS AND ANALYSIS BY ENERGY AUDITOR

11KV FEEDER METERING AND ENERGY AUDIT

The DISCOM has 100% metering for all the 11 kV feeders and has provided energy input and consumption/ sale data of all the 11 KV feeders (11 kV feeders – 18 nos).

The process of checking the functioning and calibration of the 11 KV feeder meters is an on-going process and can be tested through M/s KSEBL, TMR unit as per CEA regulation.

ANALYSIS ON T&D LOSSES AND AT&C LOSSES

- % of losses – Aggregate:** - The overall Technical Loss (T&D Loss) is 6.71% and overall AT&C Loss is 7.43% for FY 2023-24. This reflects an overall collection efficiency of 99.22%. The detailed HT, LT and Transformer losses with respect to the input energy is shown in table below.

Table 78: Analysis on T&D losses

Particulars	Units	Values**
Total energy purchased	MU	182.08
Total energy sales	MU	169.87
Quantum of losses at HT level	MU	0.06
	%	0.03
Quantum of LT level losses (LT level and Transformer losses)	MU	12.15
	%	6.67
Total losses	MU	12.209
	%	6.71
Collection efficiency	%	99.223
AT & C loss	%	7.431

****Values with full decimal places.**

COMPLIANCE TO RENEWABLE PURCHASE OBLIGATIONS

TCED purchasing the 97.89% of the power consumed through KSEBL. As the KSEBL is on the verge of meeting the RPO obligation, the same can consider for the TCED. However, TCED is generating 2.11% of the total consumption through its consumers in net metering tariff by roof top solar method and through its own corporation buildings.

Table 79: Solar generation share

Total Energy Consumption FY 2023-24 (MU)	182.078	
Details	Solar generation	Non-solar generation
Present status - MU	3.85	0
Present status - %	2.11%	0

2 ENERGY CONSERVATION MEASURES

1. REPLACING HT & LT OVERHEAD LINES WITH UG CABLES

Background

As the location, Thrissur, is known for various festivals yearly, the crowd and the risk possess in the transmission of power through overhead line stays. TCED has initiated to change all the major location, identified disaster prone areas, with UG cables, especially in the HT side. Also, this will reduce the overall loss in the system.

The details of the HT & LT overhead lines in TCED for the audited 4 feeders are summarized in the table given below as sample basis. The distance given below in table are considered for the calculation.

TABLE 80 : OVERHEAD LINES DETAILS

OH Line type	Voltage level	Distance in km	Resistance of the line Ω /km
Racoon	11 kV	8.273	0.3712
Rabbit	415 V	20.97	0.543

Proposal

1. The resistance per line length for UG cables is 0.13 Ω /km for 300 sqmm XLPE which will reduce the power loss through HT overhead line and thereby the net power losses in the system. Estimated reduction in energy loss is 70% from the present losses.
2. The detailed calculation for savings has been done for 4 feeders which is applicable to remaining 12 feeders and financial viability is shown in the table given below.

Calculation

TABLE 81 : ECM 01

Particulars	Units	Equation	Bini	Ramanilayam	Chembukavu	Shornur road
Present HT Line loss	kWh/annum	A	401	858	2570	1822
Present LT line loss	kWh/annum	B	61701	75030	524636	631602
Estimated HT line loss after reconductoring with UG	kWh/annum	$C = A \times 0.13/0.3712$	140	300	900	638
Estimated LT line loss after reconductoring with UG	kWh/annum	$D = B \times 0.13/0.543$	14747	17932	125388	150953
Annual Savings	kWh/annum	$E = C + D$	47215	57656	400918	481833
HT line Distance to be reconductored with UG	km	F	1.71	1.128	3.317	2.118
LT line Distance to be reconductored with UG	km	G	2.805	3	6.605	8.56
Total distance	km	$H = F + G$	4.515	4.128	9.922	10.678
Energy charges	Rs/kWh	J	6.65	6.65	6.65	6.65
Reconductoring charges as per TCED estimate	Rs/km	K	6,00,000	6,00,000	6,00,000	6,00,000
Annual Financial savings	Rs/annum	$L = E \times J$	3,13,980	3,83,409	26,66,108	32,04,192
Investment cost	Rs	$M = K \times H$	27,09,000	24,76,800	59,53,200	64,06,800
Net Annual Financial Savings	Rs	$N = \text{Total of L}$	65,67,690			
Net Investment	Rs	$P = \text{Total of M}$	1,75,45,800			
Simple Pay Back Period	Months	$Q = P \times 12/N$	32			

**Resistance of UG cable = $0.13 \Omega/\text{km}$

Resistance of HT Racoon OH line cable = $0.3712 \Omega/\text{km}$

Resistance of LT Rabbit OH line cable = $0.543 \Omega/\text{km}$

2. REPLACEMENT OF OLD TRANSFORMER WITH ENERGY EFFICIENT

Background & proposal

The replacement of transformers is proposed in locations where the age of transformer is greater than 30 years. It is proposed to replace the old transformers with new star rated transformer which will significantly reduce transformer losses in distribution.

Some of the transformer identified for the replacement under the RDSS scheme also comes under our 4 feeders for which we were able to analyse the actual loss variation.

The identified transformers for the replacement are given in the table below.

Sl.no	Transformer name	Capacity in (KVA)	Year of Manufacturing	Feeder
1	Varnam	315	1987	Shornur road
2	Trichur/ Malabar Eye Clinic	250	1988	Shornur road

The calculation for the saving through replacement of transformer is given in the table below:

Table 82: ECM 02

Particulars	Units	Equation	Values
Present unit loss in above transformers	kWh/annum	A	14,343
Estimated unit loss in energy efficient transformers - considering the same transmitted power based on FY 2023-24 value	kWh/annum	B	2,292
Difference in unit loss	kWh/annum	C = A-B	12,052
Energy charges	Rs/kWh	D	6.65
Annual financial savings	Rs/annum	E = D x C	80,144
Estimated investment cost for transformer replacement - for 250 kVA transformer	Rs/unit	F	7,00,000
Number of units that need replacement	Nos	G	2
Net investment	Rs	H = F x G	14,00,000
Simple payback period	Months	J = H x 12/E	210
	Years	K = H / E	17

Note: Losses considered for transformer replacement evaluation is mentioned in the table below.

	kVA	Iron loss	Cu loss
Present transformer	250	670	2650
	315	900	3200
Energy efficient transformer	250	100	670
	315	100	900

3. POWER FACTOR IMPROVEMENT TO NEARY UNITY

Background

1. The average power factor during the measurement period (5-hour logging) at 110kV incomer was 0.97 lagging.
2. However, while measuring the feeder level power parameters during the audit period, at the substation, auditors noticed that the PF was lower in the following feeders.

TABLE 83: PF & REACTIVE POWER OF MAJOR FEEDERS

Sl no	Feeder name	Average PF	Measured KVAR - Avg	Incomer
1	Poonkunnam	0.93 lag	228	66kV
2	Keralavarma	0.94 lag	199	66kV
3	Kottappuram	0.91 lag	247	110kV
4	Aranattukkara	0.97 lag	389	66kV
5	Mission Quarters	0.97 lag	268	110kV
6	Koorkanchery	0.97 lag	261	110kV
7	Paravattani	0.97 lag	310	110kV

3. The average PF during the period from April-2023 to March-2024 at the 110kV as well as 66kV incomer was registered as 0.97 lagging and 0.96 lagging respectively.

Proposal

1. Install LT capacitors of 60kVAR rating at 5 locations, ie; at the secondary side of selected 5 distribution transformers, for the above-mentioned feeders under 66kV incomer.
2. Install LT capacitors of 120kVar rating at 15 locations, ie; at the secondary side of selected 15 distribution transformers, for the above-mentioned feeders under 110kV incomer.
3. Awareness campaign shall be given to major consumers to install capacitors especially for the commercial buildings and apartment flats which will significantly reduce the losses in the respective feeders along with the improvement in PF.
4. KSEBL is entitled to give power factor incentive considering the agreement between the TCED which signed on 1949. However, the incentive was denied and in dispute.

Table 84: ECM 03

66 KV INCOMER						
Month	Power Factor present	Billing Demand kVA	Proposed PF	Billing Demand after PF improvement kVA	Reduction in Billing Demand kVA	Reduction in Demand Charges Rs
Apr-23	0.97	16,742	0.99	16,404	338	1,28,524
May-23	0.97	18,112	0.99	17,746	366	1,39,042
Jun-23	0.97	16,261	0.99	15,932	329	1,24,832
Jul-23	0.97	12,974	0.99	12,712	262	99,598
Aug-23	0.97	14,749	0.99	14,451	298	1,13,225
Sep-23	0.97	16,107	0.99	15,782	325	1,23,650
Oct-23	0.97	16,610	0.99	16,274	336	1,27,511
Nov-23	0.97	14,837	0.99	14,537	300	1,19,895
Dec-23	0.97	14,636	0.99	14,340	296	1,18,271
Jan-24	0.97	14,740	0.99	14,442	298	1,19,111
Feb-24	0.97	15,763	0.99	15,445	318	1,27,378
Mar-24	0.97	17,121	0.99	16,775	346	1,38,352
Annual reduction in demand charges						14,79,388
Annual energy charges (Rs/Annum)						36,93,28,870
Present average annual PF						0.96
Incentives towards improving PF from 0.97 to 0.99 (Rs/Annum)						36,93,289
Present annual penalty paid towards low power factor (Rs/Annum)						Nil
Net annual savings via PF improvement (Rs/Annum)						51,72,677
Estimated investment cost for the improvisation (awareness campaign among major consumers, Installation of 60 kVAr LT capacitors each in 5 locations)						7,50,000
Simple payback period (Months)						2
110 kV incomer						
Month	Power Factor present	Billing Demand kVA	Proposed PF	Billing Demand after PF improvement kVA	Reduction in Billing Demand kVA	Reduction in Demand Charges Rs
Apr-23	0.96	23,760	0.99	23,040	720	2,73,600
May-23	0.96	26,800	0.99	25,988	812	3,08,606
Jun-23	0.97	21,480	0.99	21,046	434	1,64,897
Jul-23	0.97	18,740	0.99	18,361	379	1,43,863
Aug-23	0.97	22,160	0.99	21,712	448	1,70,117
Sep-23	0.97	18,360	0.99	17,989	371	1,40,945
Oct-23	0.97	18,360	0.99	17,989	371	1,40,945
Nov-23	0.97	22,360	0.99	21,908	452	1,80,687
Dec-23	0.97	19,420	0.99	19,028	392	1,56,929
Jan-24	0.97	18,600	0.99	18,224	376	1,50,303
Feb-24	0.96	20,100	0.99	19,491	609	2,43,636
Mar-24	0.96	23,040	0.99	22,342	698	2,79,273
Annual reduction in demand charges (Rs/Annum)						23,53,802
Annual energy charges (Rs/Annum)						64,41,92,670
Present average annual PF						0.96
Incentives towards improving PF from 0.97 to 0.99 (Rs/Annum)						96,62,890
Present annual penalty paid towards low power factor (Rs/Annum)						Nil
Net annual savings via PF improvement (Rs/Annum)						1,20,16,692
Estimated investment cost for the improvisation (awareness campaign among major consumers, Installation of 120 kVAr LT capacitors each in 15 locations)						30,00,000
Simple Payback period (Months)						3

4. STEPS TO ENSURE THE REDUCTION OF LOSSES IN THE TRANSFORMER

Background

1. Estimated transformer loss using the consumer consumption data for the FY 2023-24 is 1.515% which amounts to 2.419 MU of the total income 159.665 MU.
2. The transformer loss is evaluated based on the average loading at the secondary side of the transformer which is being detailed in the section Annexure: collected data.
3. Auditor observed during the field study that some of the transformer especially the ones that are metered at the secondary side are heavily underloaded.
4. The major reason for the low loaded transformer is:
 - Due to the over extrapolation by the consumer/contractor regarding the demand in the location.

For the LT consumers such as apartment, commercial buildings, etc, transformers are being purchased by the client (consumer) which would be in higher rating. If such consumer is billed in the LT section, the metering will be at the secondary of the transformer, which results in low efficiency (High transformer loss% - estimated) running when the low loading happens in the same. The list of transformers that shown low efficiency due to the low loading for the FY 2023-24 is shown in the table below:

TABLE 85: LOW LOADING TRANSFORMER LIST

Feeder name	Transformer name	Transformer ownership (Client/ Department)	KVA rating	% loading - avg	Loss in kWh/ month	Transformer loss % - estimated
East fort	Reliance-2 (City Palace-2)	Client	315	2.52	541.2	11.94
	East Fort Tower	Client	200	2.26	300.7	11.66
Kerala varma	Temple Tower	Client	250	2.38	402.9	11.85
	Chowallur Tower	Client	400	2.06	660.89	14.05
Koorkanchery	Smart Centre	Department	100	3.34	259.1	13.61
Bini	Kairali Sree Theatre 1	Client	200	1.34	330.3	21.69
Ramanilayam	Stadium West	Department	250	1.18	402.2	22.8
Shornur	City Centre 2	Client	160	2.08	276.5	14.6
	Top Heritage	Client	160	1.71	276.3	17.7
Mission quarters	Chemmannam 160	Client	160	2.25	276.6	13.49
Paravattani	Wheels Apartment	Client	160	2.01	276.5	14.9
	CIDBI Apartment	Client	400	2.04	660.9	14.1
	Manjali Enclave	Client	160	1.81	276.4	16.5

Feeder name	Transformer name	Transformer ownership (Client/ Department)	KVA rating	% loading - avg	Loss in kWh/month	Transformer loss % - estimated
Veliyanoor	Hari Sree Apartment	Client	160	1.54	276.3	19.71
	MRG Flat	Client	250	1.26	402.3	22.36
	Emerald 2	Client	160	0.02	276	1790
	Manichitra Arcades	Client	200	1.38	300.3	19.02
Total (kWh/month)					6195.39	
Annual Loss (MU) - estimated					0.07434	

Proposal

1. The metering point of such consumers, where the client is installing transformer and seeking LT connection, shall be changed to the High voltage side. This will reduce the losses occurring due to the transformer low loading and the transformer loss will accommodate in the billing.
2. Matter needs to be took up with KSERC for implementing the same as the existing regulations does not cater such connection for LT consumers.
3. Estimated reduction in the transformer loss is 3.07% which accounts to 0.743 lakhs units per annum.
4. Estimated financial savings by the changing the metering point to High voltage side for the above listed transformers are Rs 4.83 lakhs per annum.
5. Also proposed to replace the old rewinded transformer with new five star rated ones which will reduce the overall transformer loss from the existing 1.515%.
6. A detailed transformer loss study analysis shall be done separately to analyse the same, in the meantime, DISCOM can select the transformers that are older than 30 years for replacing.

Table 86: ECM-04

Particulars	Units	Values
Present annual unit loss by metering at Low voltage side of the transformer for LT consumers	kWh/annum	74,340
Cost per unit	Rs/kWh	6.65
Annual financial loss	Rs/annum	4,94,361
Estimated investment for one CT & PT connection from the DISCOM side	Rs/location	1,25,000
Number of locations taken into consideration for this analysis	Locations/ trfr nos	18
Estimated total investment	Rs	22,50,000
Simple payback period	Months	55
	Years	4.55

ANNEXURE: COLLECTED DATA

1. ABOUT THE ACCREDITED ENERGY AUDIT FIRM

Centre for Energy Environment and Productivity (CEEP) is an Empanelled Accredited Energy Auditing Firm (EAEA) recognised by BEE. Consulting and training in the areas of energy audit, ISO 50001, cleaner production and environmental management,

Empanelled Accredited Energy Auditor with Bureau of Energy Efficiency (BEE) which have wide experience in the energy audit sector and have conducted the same in Chemical, Textile, Steel and DISCOM.

NAME AND DETAILS OF ENERGY MANAGER/AEA

M/s TCED, Thrissur District-Kerala -680001 have a BEE Certified Energy Auditor – Mr. Nikhil B (CEA – 24811), whom will be the signatory for all BEE activities.

On behalf of Centre for Energy Environment and Productivity (CEEP), Mr. Ashok K M P (CEA 34760/22) signed the quarterly Energy accounting report for the financial year 2023-24 and will be sign for the upcoming FY 2024-25.

The contact details of Accredited energy auditor and Energy manager from CEEP is given in the table below.

TABLE 87: CONTACT DETAILS OF AEA & CEA

Sr No	Name	Certification	EM/EA/AEA/Registration No	Phone no	Email
1	Mr. J Nagesh Kumar	• Accredited Energy Auditor	AEA-0133	9444882553, 8668115663	ceepnagesh@gmail.com
2	Mr. Sunil kumar V K	• Sector Expert	EA – 3642	9497752463	vkoilothsunil@gmail.com
3	Mr. Ashok K M P	• Certified Energy Auditor	EA-34760/22	7356111991	ashokkmp@gmail.com
4	Ms. Della David	• Certified Energy Auditor	EA 34867/22	7356111992	delladavid19984@gmail.com

2. CHECKLIST PREPARED BY AUDITING FIRM

1. KSEB bill –FY 2023-24 – April to March
2. Truing up & ARR Document –FY
3. Bill collection data as per the performa for the FY
4. Annual financial statement – P&L – balance sheet
5. Electricity Transmission and consumption data: Both FY (year wise)
 1. Substation meter reading
 2. Feeder meter readings -
 3. HT consumer meter reading - corresponding feeder wise
 4. LT consumer meter reading
 5. Solar export data – unit, location, size of the plant, voltage level, metering type (net or gross), feeder name, consumer no:
6. Transformer details
 1. Incomer transformer data
 2. Feeder wise transformer data (HT and DT separately)
 3. Name plate details of transformers
 4. No load and Copper loss of transformers
7. Energy Meter data
 1. Feeder meter & DT meter – serial no., type of meter
 2. Consumer meter – type & its number
8. HT network diagram (GRID Map)
9. Incomer substation single line diagram
10. Cable details
 1. HT cable – type, location, size, length
 2. LT cable – type, location, size, length
 3. HT & LT overhead line – type
11. Street light – number, location (estimate)
12. Quarterly Performa sheet submitted during the last FY to BEE

3. APPROACH, SCOPE & METHODOLOGY OF ENERGY AUDIT

PERIOD OF AUDIT

The energy audit field study was carried out during the period from 27th June 2024 to 12th August 2024 for the field study is given in the table below.

Table 88: Activity chart – Energy audit

ACTIVITIES	27 th June 2024	27 th July to 03 rd August 2024	4 th August to 12 th August 2024
<ul style="list-style-type: none"> Kick-off meeting with the concerned DISCOM officials Data collection site survey plan 			
<ul style="list-style-type: none"> Site survey 11kV HT line mapping DT mapping Feeder wise measurement at switching station. Metering deviations of major HT consumers. 			
<ul style="list-style-type: none"> Verification of T&D Losses, other Calculation Finalization of form and submission of draft report 			

SCOPE OF AUDIT

- Study and validation of the methodology adopted, data source and its accuracy of the energy audit works carried out for internal as well as external reporting in the following areas.
 - 11 kV level for study of 11 kV distribution loss in 06 feeders.
 - Losses incurred in individual 11 kV feeders
 - Calculation of technical loss of 11 kV line
 - Sample LT level study of Distribution transformer and LT distribution loss.
 - Losses incurred in LT line of different 11/0.433 kV distribution transformer in each feeder on 10% sample basis.
 - Calculation of technical loss of LT line with actual LT line data.
 - Selection of the distribution transformer shall be based on the differentiated consumer pattern, length of the distribution lines, old lines etc.
- Collection and Review of the energy related data of last Financial Year (FY) in the Proforma by visiting the DISCOM physically.

3. Verification of existing pattern of energy distribution across periphery of electricity distribution company
4. Collection and verification of energy flow data of electricity distribution company at all applicable voltage level of distribution network.
5. Collection of data on energy received and distributed by DISCOM and verify the accuracy of data
6. Collection & analysis the data and prepare the same with report;
7. Input energy details:
 - a) Collection of input energy from recorded system meter reading
 - b) All the inputs points of transmission system
 - c) Details provided by transmission unit
 - d) System loading and Captures infrastructure details (i.e., no of circle, division, sub-division, feeders, DTs, & Consumers).
8. Parameters for computation of distribution losses:
 - a) Details of open access, HT sale, LT sale and transmission losses
 - b) Number of consumers category wise in each circle
 - c) Consumers connected load category wise in each circle
 - d) Details of billed and un-billed energy category wise of each circle
 - e) Metered and un-metered details.
 - f) Boundary meter details
 - g) Energy Cost and Tariff data
 - h) Source of energy Supply (e.g., electricity from grid or self-generation), including generation from renewables;
 - i) Energy supplied to Open Access Consumers which is directly purchased by Open Access Consumers from any supplier other than electricity distribution company
9. Monitoring and verifications of input energy and consumption pattern at various voltage levels
10. Identify the areas of energy leakage, wastage or inefficient use;
11. Identify high loss-making areas/networks, for initiating target based corrective action;
12. Identify overloaded segments of the network for necessary capacity additions.
13. Computation of agriculture consumption (approved by SERC)
14. Methodology for loss computation various losses.
15. Computation of Average Billing Rate (ABR)
 - a) Total revenue billed category wise.
 - b) Category wise ABR with tariff subsidy.
 - c) Category wise ABR without tariff subsidy.

- d) Collection Efficiency (Category wise) and computation of AT&C loss.
16. Observe and compile various Energy Conservation (ENCON) options implemented by the DISCOM and prepared report containing details of expenditure made by DC along with saving and payback period.
 17. Recommendations to facilitate energy audit, energy accounting and improve energy efficiency
 18. Study the details of loss/gain of DISCOM, analysis of Average Cost of Supply (ACS) and Average Revenue realized (ARR) gap, details of energy charges/Power purchase cost along with the financial analysis.
 19. Current System Metering Status at various voltage level of DISCOM
 - a) Status of Functional meters for all consumers, transformers and feeders.
 - b) Status of default meters (non-functional meters) for all consumers, transformers and feeders
 20. Current status of pre-requisites mentioned in regulations.
 21. Copies of relevant authentic and certified documents should support the report. Each document should be sealed and signed by DISCOM authorized representative as well as by agency's AEA.
 22. Prepare final report of DISCOM as per the scope of work and as per the regulation of Energy Audit, 2021, in a standard format duly indexed, covering profile of the unit and its details of energy related data w.r.t. DISCOMs Sector, analytical & Statistical details and any other relevant information.

METHODOLOGY

In order to meet requirements of the scope of Work, CEEP, adopted the following phase wise approach for completion of the assignment

Phase 1 – Pre-audit phase

- a. Kick off meeting with DISCOM officials.

The following were the agenda during the kick off meeting.

- Introduction of the team
- Briefing of energy audit – Schedule of plan & execution
- Discussion about data collection format.
- Discussion on the scope of energy audit

After detailed deliberations following points were discussed.

- TCED will provide the transportation facility for the field measurement.

- TCED will provide a single person of contact for the energy audit assistance who has access to the T Soft (TCED internal software).
 - TCED will provide an engineer in the field who has knowledge on the distribution lines
- b. Assigning of team members.
- c. Collection and Review of the energy related data

Phase 2 – Audit phase

Field survey:

- a. The field survey had been conducted for HT lines and transformers of the designated area as representative data for compiling a comprehensive and diligent assessment.
- b. A detail route plan of the distribution network had been also ascertained by way of segmenting data through walk down surveys along 11kV incoming feeder and corresponding 11kV feeders were also surveyed.
- c. Hourly load analysis was done for all the six feeders and feeder energy meters were calibrated against the power analyzer.
- d. HT lines & Transformers are mapped using the Global positioning system (GPS).
- e. HT line length and partial LT line length were identified using the GPS.
- f. The consumption data, type of cable, transformer details etc were collected from the DISCOM and verified with the field data.
- g. Analysis of various types of losses in the system was done. Various losses in the system are as listed below.

Technical Losses:

- HT (11 kV) line losses
- Distribution transformer losses (Iron & Copper losses).
- L.T. Line losses
- HT and LT cable losses

Miscellaneous technical losses

- Losses due to loose jump connections in the line
- Losses due to short circuits & earth faults Losses in service mains of installations.
- Losses incurred in CT'S of energy meters.
- Losses incurred in old static energy meters.

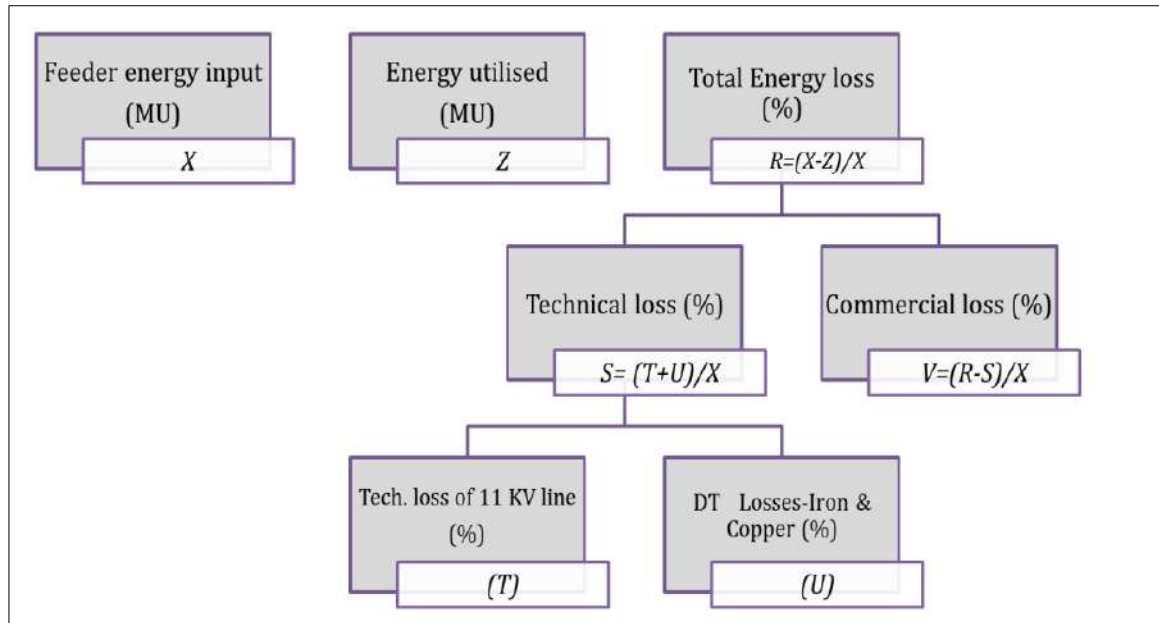

Figure 25: Schematic representation of technical losses

Commercial losses

- Mistakes in the billing.
- Meters not recording (MNR)
- Meters not recording correctly
- Meters bye passed due to defects/ intentionally.
- Meters not read & billed.
- Theft and pilferage.

Phase 3 – Post audit phase

After the identification of various loss reduction initiatives based on the HT & LT distribution detailed analysis was carried out in this phase of the study to prepare a strategy for loss reduction. Under this strategy, detailed steps are defined for loss measurement, energy audit and loss verification as well. A Final Report was prepared after discussion with TCED officials. Submitted the report with complete database and techno economic analysis.

CALCULATIONS INVOLVED IN LOSS ANALYSIS

Technical losses occur in the system due to cables, overhead lines, transformers and other equipment in the substation. The losses in cables and overhead lines depends on the length, type of the cable/overhead line as well as the current passing through it.

The length of the overhead lines could be determined after mapping HT/LT lines and transformers using GPS and the type of overhead line was identified. The type of HT/LT cables, its length, were collected during the field visit. The energy consumption pattern during the previous 12 months for all HT consumers and LT consumers (under each distribution transformer) were analyzed and average monthly energy consumption was noted.

A. LT Losses

For LT side, the average monthly energy consumption is noted (at the transformer secondary side). The **LT overhead line losses** are calculated as per the formula given below

$$LT \text{ line losses per month } \left(\frac{kWh}{month} \right) = 3I_L^2 * R_L * d * 24 * 30 \dots\dots\dots (1)$$

Where: I_L = average value of current passing through the LT overhead line (A)

R_L = Resistance/km of the LT overhead line (Ω /km)

d = mean length of the LT overhead line (km)

The value of I_L can be calculated from the total average monthly kWh consumption of all consumers under a single Distribution Transformer as per the following equation

$$I_L = \frac{\text{Total Average monthly kWh consumption under each Distribution Transformer } \left(\frac{kWh}{month} \right) * 1000}{\sqrt{3} * 400 * 24 * 30} \dots\dots\dots (2)$$

Now, Energy transmitted from the pole of the distribution transformer (DT) is given by

$$\begin{aligned} & \text{Energy transmitted from the pole of DT } \left(\frac{kWh}{month} \right) = \\ & \text{Total energy consumption under each DT } \left(\frac{kWh}{month} \right) + \text{LT line losses } \left(\frac{kWh}{month} \right) \dots\dots\dots (3) \end{aligned}$$

LT cable line losses are calculated as follows:

$$LT \text{ cable losses per month } \left(\frac{kWh}{month} \right) = \frac{3I_c^2 * R_c * d * 24 * 30}{1000} \dots\dots\dots (4)$$

Where: I_c = average value of current passing through the LT cable (A)

R_c = Resistance/km of the LT cable (Ω /km)

d = length of the LT cable (km)

The value of I_c can be calculated from the total average monthly energy transmitted from the pole of each Distribution Transformer as per the following equation

$$I_c = \frac{\text{Total Average monthly energy transmitted from pole of each Distribution Transformer (kWh/month)} * 1000}{\sqrt{3} * 400 * 24 * 30} \dots\dots(5)$$

Now, the energy at the secondary side of each distribution transformer is given by

$$\begin{aligned} &\text{Energy at the secondary side of each DT } \left(\frac{\text{kWh}}{\text{month}} \right) = \\ &\text{Total energy transmitted from pole of each DT } \left(\frac{\text{kWh}}{\text{month}} \right) + \text{LT cable losses } \left(\frac{\text{kWh}}{\text{month}} \right) \dots\dots\dots(6) \end{aligned}$$

B. Transformer losses

The major losses in a transformer are accounted as Core losses and Copper losses. Core losses are independent of the transformer loading whereas Copper losses depends on the loading factor. The transformer losses are given by the formula as

$$\text{Transformer losses } \left(\frac{\text{kWh}}{\text{month}} \right) = \frac{(P_{core} + x^2 * P_{Cu}) * 24 * 30}{1000} \dots\dots\dots(7)$$

Where: P_{core} = Transformer core losses (W)

P_{Cu} = Transformer Copper losses (W)

x , Transformer loading factor = Total average monthly Energy at the transformer secondary (kWh/month) / (Average monthly Power Factor * Transformer capacity in kVA)

Thus, the total energy transmitted the HT side of each distribution transformer is given by the equation

$$\begin{aligned} &\text{Total average monthly energy transmitted from the transformer primary } \left(\frac{\text{kWh}}{\text{month}} \right) = \\ &\text{Average monthly energy transmitted from the transformer secondary } \left(\frac{\text{kWh}}{\text{month}} \right) + \\ &\text{Transformer losses } \left(\frac{\text{kWh}}{\text{month}} \right) \dots\dots\dots(8) \end{aligned}$$

C. HT losses

For HT consumers the average monthly energy at the transformer HT side is available and the HT overhead line loss was calculated as per follows:

$$\text{HT line loss per month } \left(\frac{\text{kWh}}{\text{month}} \right) = 3I^2 * R * D * 24 * 30 \dots\dots\dots(9)$$

Where: I = average value of current passing through the overhead line (A)

R = Resistance/km of the HT overhead line (Ω /km)

D = length of the overhead line (km)

The value of average current is found from the average monthly energy consumption recorded at the HT side as $I = \frac{\text{average monthly kWh recorded at HT metering side}}{24 \times 30 \times 11 \times \sqrt{3}}$ (10)

For LT consumers under distribution transformer the energy transmitted from the HT side of each distribution transformer is calculated as per equation (9)

$$\begin{aligned} & \text{Total monthly average energy transmitted from the pole at switching station } \left(\frac{\text{kWh}}{\text{month}} \right) = \\ & \text{Total monthly average energy transmitted from the transformer primary } \left(\frac{\text{kWh}}{\text{month}} \right) + \\ & \text{Total monthly average HT overhead line losses } \left(\frac{\text{kWh}}{\text{month}} \right) \dots\dots\dots(11) \end{aligned}$$

HT Cable losses is given by equation (12) as follows

$$\text{HT cable losses } \left(\frac{\text{kWh}}{\text{month}} \right) = 3 I_T^2 * R_{HTcable} * D_c * 24 * 30 \dots\dots\dots(12)$$

Where: I_T = average current through the HT cable (A)

$R_{HTcable}$ = Resistance/km of HT cable (Ω /km)

D_c = length of HT Cable from incomer to Pole at switching station

The total monthly average energy transmitted from the feeder incomer =

$$\begin{aligned} & \text{The total monthly average energy transmitted from the feeder incomer (kWh/month)} \\ & = \text{Total monthly average energy transmitted from the pole at switching station} \\ & + \text{HT cable losses} \end{aligned}$$

D. Feeder Meter Calibration

Continuous logging was done at each feeder for a period of 24 hours during a normal working day. The energy transmitted from each feeder was recorded using power analyzer and it is compared against the power analyzer readings. Percentage of error in the feeder side energy meter was found using the formula shown below.

$$\% \text{ of error} = \frac{(\text{Feeder energy meter reading} - \text{Power analyser reading}) * 100}{\text{Power analyser reading}}$$

LIST OF INSTRUMENTS

The instruments used for the measurements and analysis as a part of electrical distribution audit were as follows:

Table 89: Equipment list

Equipment/software name	Make	Model	Purpose
Portable load manager	Krykard	1. ALM 31 2. ALM 35	Load and distribution loss analysis, Meter deviation
Global positioning system meter	Garmin	Etrex 10	For mapping the HT lines and to have the coordinates of the transformers
Easy GPS software			For mapping the co-ordinates
Google maps			For mapping

4. INFRASTRUCTURE DETAILS

The infrastructure details of the TCED DISCOM are given below as per the Performa filled out and verified by the accredited energy auditor.

Table 90: Infrastructure details

Form-Details of Input Infrastructure					
1	Parameters	Total	Covered during in audit	Verified by Auditor in Sample Check	Remarks (Source of data)
i	Number of circles	1	1	1	
ii	Number of divisions	1	1	1	
iii	Number of sub-divisions	1	1	1	
iv	Number of feeders	18	18	16	88.88% of the Total feeder
v	Number of DTs	480	480	410	85.42% of the total DT. Transformers of HT consumers not included in the list
vi	Number of consumers	42995	42995	34282	79.73% of the total consumers
2	Parameters	66kV and above	33kV	11/22kV	LT
a.	Number of conventional metered consumers	-	-	-	8130
i.					
ii	Number of consumers with 'smart' meters	-	-	-	-
iii	Number of consumers with 'smart prepaid' meters	-	-	-	-
iv	Number of consumers with 'AMR' meters	-	-	-	-
v	Number of consumers with 'non-smart prepaid' meters	-	-	139	34726
vi	Number of unmetered consumers	-	-		
vii	Number of total consumers	-	-	139	42856
b.i.	Number of conventionally metered Distribution Transformers	-	-	-	286
ii	Number of DTs with communicable meters	-	-	-	-
iii	Number of unmetered DTs	-	-	-	194

iv	Number of total Transformers				480
c.i.	Number of metered feeders			-	
ii	Number of feeders with communicable meters			18	
iii	Number of unmetered feeders			-	
iv	Number of total feeders			18	
d.	Line length (ct km)		4.2	117.278	287.953
e.	Length of Aerial Bunched Cables			1.85	-
f.	Length of Underground Cables		2.565	73.98	4.525

5. ELECTRICAL DISTRIBUTION SYSTEM

Thrissur is known as the cultural capital of Kerala and it is the administrative capital of Thrissur district. Thrissur is known as the cultural capital of Kerala because of its cultural, spiritual and religious leanings throughout history. It is famous for Thrissur Pooram festival, one of the most colourful and spectacular temple festivals of Kerala from ancient times. Thrissur has been politically, economically and culturally significant to the Indian subcontinent. The city is built around a 65-acre (26 ha) hillock called the Thekkinkadu Maidanam. Thrissur was once the capital of the Kingdom of Cochin and was a point of contact for Arabs, Romans, Portuguese, Dutch and English.

The Thrissur Municipal Corporation manages the distribution of electricity to the residents and Commercial establishments through **Thrissur Corporation Electricity Department**. The distribution network covers about 12.65 Sq. km. Thrissur Corporation Electricity Department (TCED is one of the 10 electricity distribution Licensees in the state of Kerala. The present TCED has 40000 plus consumer strength and the annual energy sale is about 160 MU. TCED has its own 110 kV, 66 kV and 33KV substations with 468 distribution transformers. **Thrissur Corporation is unique in that it is the only local body engaged in the distribution of electricity and aims to become an ideal licensee in India.**

With the support and consent of various govt agencies, TCED has been implementing various programs and projects for efficient use of energy and conservation. TCED has already commissioned 500 kW Solar Power plant, and orientates at more solar plants near future. In addition, TCED will soon be having its own Small Hydel Projects as much as 4 projects are already allotted to TCED by the Kerala Government.

TCED has not availed any funding so far under central support and missed modernisation and strengthening under APDRP, RAPDRP and IPDS.

Presently, as of December 2023, **TCED came under the RDSS and implementing all the required measures as per the Regulations of Energy accounting.** AT& C loss & Revenue gap for TCED is below bench marks but for an area currently handled by TCED this figure is high due to non-segregation of loss data which will be covered in Smart meter program under the RDSS with system metering.

The billing system, ERP covering Material/Procurement, Accounts and HR are missing and more importantly this utility does not have any GIS mapping of consumers and indexing them to Feeder/DTR/Consumer that enable clear energy auditing. This will be covered under IT-enabled system.

As far as KSERC filing is concerned, TCED has equal responsibility as that of other licensees within the state and compliance to variance regulations and statutory filings are mandatory and these reforms now suggested are just for these requirements only and is expected that KSERC will concur for such investment appraisals.

ELECTRICAL NETWORK CONFIGURATION

The Thrissur Corporation Electricity Department (TCED) receives power at two supply voltage:

1. 110 kV – receives at Aswini substation.
2. 66 kV – receives at Aswini Substation

The However, the Thrissur Corporation Electricity Department (TCED) have three substations in the name of its voltage level.

1. 110 kV substation at Aswini.
2. 66 kV substation at Aswini.
3. 33 kV substation at Ikkandawarrior Road.

The supply receives at 110 kV and stepdown to 11 kV feeders using 2 nos of 12.5 MVA transformers installed in the yard. Another 110-kV bus is passed through the 01 no of 16 MVA transformer to stepdown at 33 kV voltage and transmitted to 33 KV substation. In the 33-kV substation 02 nos of 5 MVA transformer will stepdown the supply to 11 kV and supplies to the feeders.

The supply that receives at 66 kV gets stepdown using 2 nos of 10 MVA transformers installed in the yard.

SUBSTATION DETAILS**➤ TRANSFORMER AND FEEDER DETAILS – SUBSTATION**

Transformer details in each substation is given in the table below:

Table 91: Substation transformer details

S/s	TR. No	Capacity of Transformer	Voltage level	Current	Volt impedance	Serial No.	MFD Name	Date of MFD
		MVA	KV	A	%			
66 kV	TR-1	10	66/11	87.5/525	9.57	120285-1	TELK	1988
	TR-2	10	66/11	87.5/525	9.71	120285-2	TELK	1989
	TR-3	10	66/11	87.6/525	9.97	120495	TELK	2005
110 kV	TR-1	12.5	110/11	65.7/657	10.21	120553-1	TELK	2008
	TR-2	12.5	110/11	65.7/657	10.12	120553-2	TELK	2008
	TR-3	16	110/33	84.1/280	10.31	120554	TELK	2008
33 kV	TR-1	5	33/11	87.6/263	7.14	110125-1	TELK	2009
	TR-2	5	33/11	87.6/263	7.01	110125-2	TELK	2009

There are 07nos of 11 kV feeders during the FY 2023-24 period under the 110-kV substation, 07 in 66 kV and 4 in 33 kV substation. The feeders are:

Table 92: Distribution Feeder name

Feeder			
33 kV s/s		110 kV s/s	
1	Paravattani	1	M O Road
2	Koorkanchery	2	Kottappuram
3	Veliyanoor	3	East Fort
4	Mission Quarters	4	Shornur Road
66 kV s/s		5	District Hospital
1	Keralavarma	6	Chembukavu
2	Poonkunnam	7	Vanjikulam
3	Bini		
4	Vivekodayam		
5	Aranattukkara		
6	Jubilee Mission Medical College		
7	Ramanilayam		

➤ **DETAILS OF CABLES AND OVERHEAD LINES - SUMMARY**

The details of 11 kV cable used at the substation is given below. The data was taken from the Single line diagram of the substation.

Table 93: Switching Station – 11 kV UG Cable Details

From	To	Cable size	Run	Core	Cable length (m)	R/km (ohm)
110/11 kV TRFR	Substation panel	500 sqmm XLPE	3	3	50	0.081
66/11 kV TRFR	Substation panel	500 sqmm XLPE	3	3	50	0.081
33/11 kV TRFR	Substation panel	300 sqmm XLPE	1	3	50	0.081
Substation panel -110/11 kV	M O Road	300 sqmm XLPE	1	3	30	0.13
	Kottappuram	300 sqmm XLPE	1	3	30	0.13
	Vanjikulam	300 sqmm XLPE	1	3	30	0.13
	Chembukavu	300 sqmm XLPE	1	3	30	0.13
	Shornur Road	300 sqmm XLPE	1	3	30	0.13
	District Hospital	300 sqmm XLPE	1	3	30	0.13
	East Fort	300 sqmm XLPE	1	3	25	0.13
Substation panel -66/11 kV	Poonkunnam	300 sqmm XLPE	1	3	50	0.13
	Keralavarma	300 sqmm XLPE	1	3	50	0.13
	Bini	300 sqmm XLPE	1	3	65	0.13
	Vivekodayam	300 sqmm XLPE	1	3	30	0.13
	Aranattukkara	300 sqmm XLPE	1	3	50	0.13
	Jubilee Mission Medical College	300 sqmm XLPE	1	3	30	0.13
	Ramanilayam	300 sqmm XLPE	1	3	30	0.13
Substation panel -33/11 kV	Paravattani	300 sqmm XLPE	1	3	30	0.13
	Koorkanchery	300 sqmm XLPE	1	3	65	0.13
	Veliyanoor	300 sqmm XLPE	1	3	30	0.13
	Mission Quarters	300 sqmm XLPE	1	3	30	0.13

The details of OH lines used in the TCED distribution system is given in the table below. The HT line length was measured using the GPS mapping and LT line length was taken from the RDSS data.

Table 94: TCED Distribution –line details

Sl. No	Feeder	HT								LT
		OH Line Length	UG Cable length							OH line Length
			95 sq.m	150 sq.mm	185 sq.mm	240 sq.mm	300 sq.mm	400 sq.mm	ABC - 120 sq mm	
m	m	m	m	m	m	m	m	m	m	
1	Bini	1838		63	122	354	1258.91		19	1710
2	Chembukavu	3,435		-	170	409	2,281		14	6,730
3	East Fort	2,119		73	47		4,641	56		9,900
4	Koorkenchery	2,782		130	232	266	2,909			10,400
5	Ramanilayam	1,811		878	221		905			3,000
6	Veliyanoor	1,493			138	32	3,703			5,580
7	Vivekodayam	2,120		40	124	86	2,508		20	5,500
8	Shornur Road	2,118		572	301		4,030			8,960
9	District Hospital	2,325		497	67	256	4,737			6,550
10	Jubilee Mission						2,821			NA
11	Arnattukkarra	4,079				214	5,731		12	NA
12	Kottappuram	2,582		63	455		2,942			NA
13	Vanjikulam	2,173		164	310	185	1,957		1,728	11,900
14	Keralavarma	2,920		157	274	123	5,428		28	8,950
15	M O Road	1,736	170	149	480	266	5,159		26	10,200
16	Mission Quarters	4,507		135	23	31	4,704	39		10,150
17	Paravattani	3,163		272	111		5,053			10,450
18	Poonkunam	2,095		230	296		3,932			11,900
Total		43296	170	3423	3373	2221	64699	95	1846	121880

➤ **TRANSFORMER DETAILS – FEEDER WISE**

The details of Transformers in each feeder wise that has been audited under the DISCOM is summarized and listed below in table. **The detailed list is provided in the Annexure.**

Table 95: Feeder wise transformer data - Summary

Sl No	Feeder	No: of Transformer	DTR Meter		No of Consumers			
			Yes	No	LT	HT	Total	
1	Mission Quarters	31	24	7	982	6	988	
2	Veliyanoor	18	9	9	1,931	9	1,940	
3	Koorkenchery	23	16	7	3,057	5	3,062	
4	Paravattani	25	18	7	2,978	6	2,984	
5	Arnattukkara	31	15	16	NA**	NA**	NA**	
6	Jubilee Mission	Dedicated feeder HT					2	2
7	Vivekodhayam	21	12	9	1,858	10	1,868	
8	Bini	16	10	6	1,002	12	1,014	
9	Poonkunam	33	10	23	2,471	5	2,476	
10	Keralavarma	38	21	17	3,437	2	3,439	
11	Ramanilayam	19	10	9	683	9	692	
12	M O Road	33	13	20	2,543	24	2,567	
13	Kottappuram	39	31	8	NA**	NA**	NA**	
14	Chembukavu	25	20	5	2,721	6	2,727	
15	Shornur Road	44	29	15	2,922	8	2,930	
16	DH	34	16	18	3,190	9	3,199	
17	East Fort	27	10	17	2,131	8	2,139	
18	Vanjikulam	23	15	8	2,247	8	2,255	
	Total	480	279	201	34153	129	34282	

**NA – Feeder or transformer wise consumer data not available in the DISCOM. DISCOM is building the database along with the RDSS scheme which will be completed by December 2024.

6. POWER PURCHASE DETAILS

POWER ALLOCATION

The State Government of Kerala allocates the energy available from various sources among the state DISCOM's to ensure balanced financial viability and fairly uniform tariff for various categories of consumers in different parts of the state. The allocation is also to ensure payment of power purchase cost including transmission and other related expenses. The point of connection charges shall be paid by DISCOM proportionate to energy allocation of each source. The TCED has only single source of power – KSEBL – which is owned and operated by the Kerala State Government. The power purchase capacity of the TCED as per the Power purchase agreement is 09 MW.

AVERAGE BILLING RATE (ABR):

ABR for a consumer category is determined by dividing total expected revenue from the category by total expected sale to that category. Mathematically, it can be represented as:

$$ABR \text{ of a category of consumer} = \frac{\text{Total Expected revenue from a category}}{\text{Total Sale of power to that category}}$$

The ABR (Average rate /kWh) of each category as per the audited sheet of TCED is given below. The net average rate/unit is given as **Rs 8.93/kWh**.

Note: There is no tariff subsidy for the DISCOM consumers as per the KSERC regulations

Figure 26: Average billing rate – category wise

Consumer type	Tariff	Number of consumers	Units	Total charges	Average rate per kWh
		Nos	MU	Rs in lakhs	Rs/kWh
Domestic	LTI	23383	46.60	2899.65	6.22
Industrial	LTIV-A	485	3.36	237.03	7.05
Industrial	LTIV-B	4	0.06	4.63	7.76
Agricultural	LTVA	181	0.06	2.45	4.44
Agricultural	LTVB	1	0.00	0.02	7.81
Non-Domestic	LTVIA	254	2.24	167.06	7.45
Non-Domestic	LTVIB	467	2.78	220.04	7.91
Non-Domestic	LTVIC	503	5.27	581.39	11.03
Non-Domestic	LTVID	32	0.06	1.41	2.38
Non-Domestic	LTVIE	43	0.07	4.96	7.01
Non-Domestic	LTVIF	716	5.43	562.51	10.36
Non-Domestic	LTVIG	83	1.11	113.26	10.21
Non-Domestic	LTVIIA	14597	49.78	5253.27	10.55
Non-Domestic	LTVIIB	1688	0.85	61.58	7.23
Non-Domestic	LTVIIC	15	0.34	31.62	9.20
Streetlight	LTVIIIB	325	1.17	58.51	5.00
Non-Domestic	LT IX	77	0.08	15.59	18.70

Non-Domestic	LTX	2	0.05	3.08	6.68
Non-Domestic	HT IA	5	0.90	72.59	8.10
Non-Domestic	HT IB	0	0.00	0.00	0.00
Non-Domestic	HT 2A	10	2.65	209.07	7.90
Non-Domestic	HT 2B	29	19.15	1805.34	9.43
Non-Domestic	HT 4	0	0.00	0.00	0.00
Non-Domestic	HT 4-A	58	14.46	1500.49	10.38
Non-Domestic	HT 4-B	36	13.02	1328.75	10.21
Non-Domestic	SPS	1	0.35	35.91	10.27
	Total	42995	169.85	15172.85	8.93

Source: **Truing up and financial year statement 2022-23

AVERAGE POWER PURCHASE COST PER UNIT

Average per unit cost power purchase for a consumer category is determined by dividing total unit purchase cost from the category by total input purchase in units. Mathematically, it can be represented as:

$$APC \text{ of a category of consumer} = \frac{\text{Total Purchase cost from a category}}{\text{Total input purchase units}}$$

The net average power purchase cost per unit of the DISCOM is available from the Trueing up document and summarised in the table below.

Table 96: Average purchase cost – DISCOM

FY	Total input energy purchased (MU)**	Total purchase cost (Rs lakhs)	APC (Rs/unit)
2020-21	129.33	8878.8	6.86
2021-22	137.59	9502	6.9
2022-23	159.12	11,632.97	7.31
2023-24	178.98	13399.61	7.49

**Total input energy purchased (MU) = Input energy (MU) at the DISCOM from 110 kV, 66kV incomer & solar export energy billed excluding solar own generation by DISCOM.

- Source: Audited balance sheet and financial year statement 2022-23

ACS - ARR GAP ANALYSIS

The Average cost of supply (ACS) and the average revenue realised (ARR) is conducted in the DISCOM during the energy audit and summarized in the below table and chart.

Table 97: ACS- ARR gap

	Input energy (MU)**	Total expenditure (Rs in lakhs)	Total revenue (Rs)	ACS (Rs/kWh)	ARR (Rs/kWh)	ACS - ARR gap (Rs/kWh)
2020-21	129.33	13615.48	13230.11	10.53	10.23	-0.3
2021-22	137.59	11,702.32	10,913.60	8.51	7.93	-0.57
2022-23	159.12	13,649.41	14,193.08	8.58	8.92	-0.34
2023-24	178.98	15,201.46	15,737.38	8.49	8.79	-0.30

**Total input energy purchased (MU) = total Input energy (MU) at the DISCOM substation and solar export energy billed excluding solar own generation by DISCOM.

- **Source:** Audited balance sheet and financial year statement 2022-23

7. SINGLE LINE DIAGRAM

110 KV & 66 KV SUBSTATION

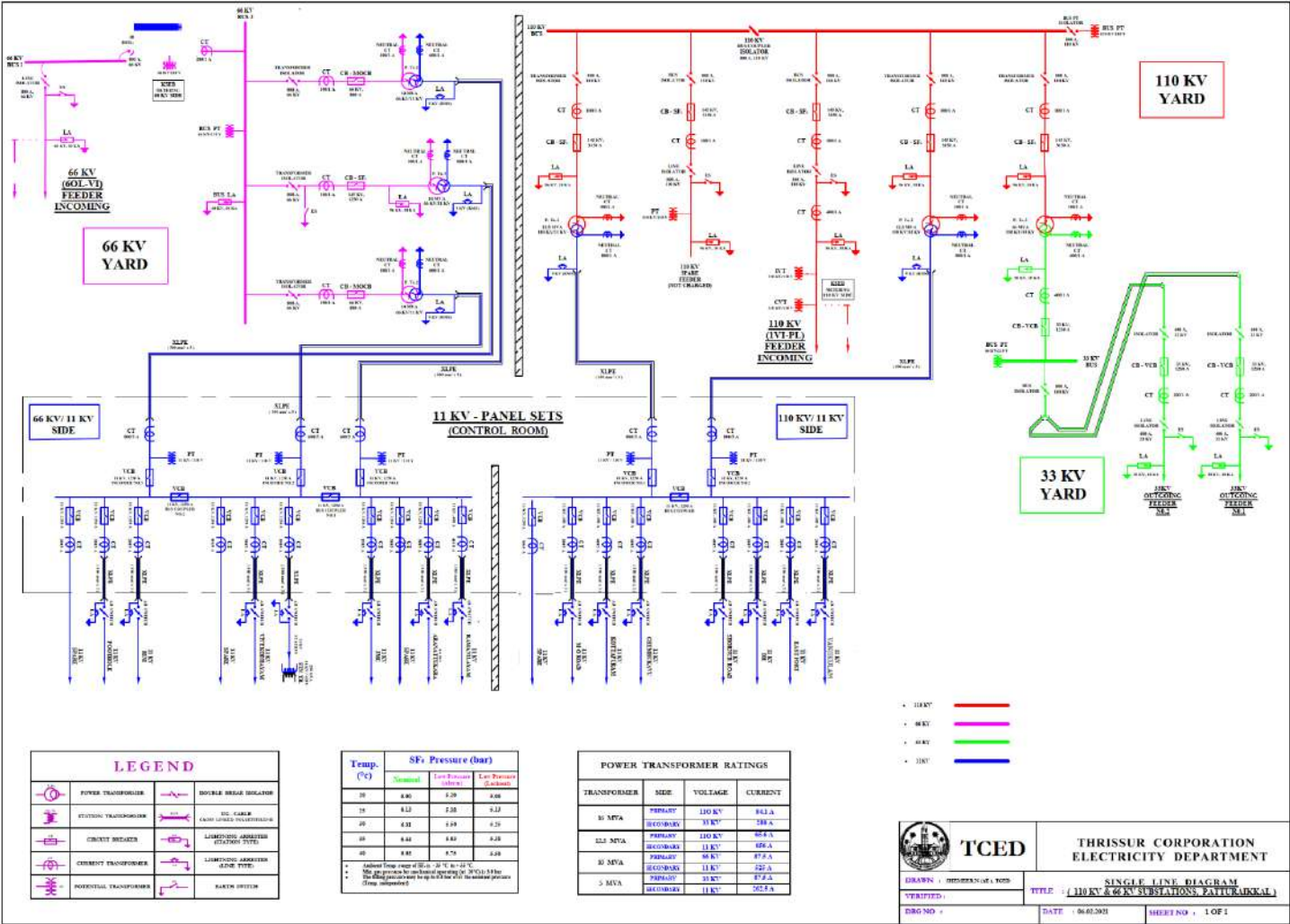

Figure 27: 110 KV & 66 KV substation

33 KV SUBSTATION

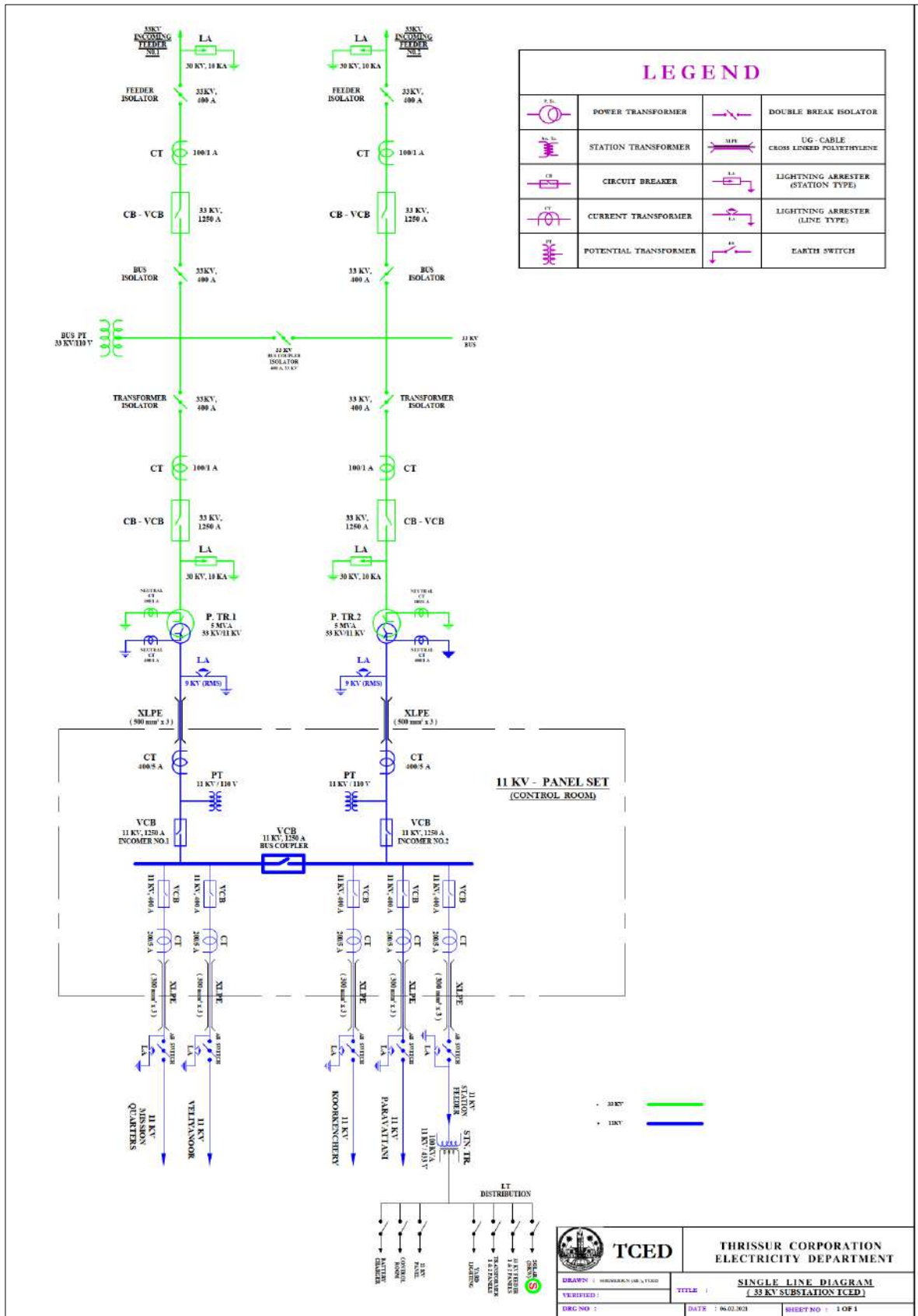

Figure 28: 33 KV substation

8. CATEGORY OF SERVICE DETAILS

DETAILS OF CONSUMERS AND CONSUMPTION

The details of consumers and consumption is given in the table below:

Table 98: Details of consumers and consumption

Summary of Energy						
Period from 1st April 2023 to 31st March 2024						
S. No	Type of Consumers	Category of Consumers (EHT/HT/LT /Others)	Voltage Level (In Voltage)	No of Consumers	Total Consumption (In MU)	Remarks (Source of data)
1	Domestic	LT	0.415	23383	46.60	
2	Commercial	LT	0.415	18222	64.69	
3	IP Sets					
4	Hor. & Nur. & Coffee/Tea & Rubber (Metered)					
5	Hor. & Nur. & Coffee/Tea & Rubber (Flat)					
6	Heating and Motive Power					
7	Water Supply					
8	Public Lighting	LT	0.415	325	1.17	VIII B
9	HT Water Supply					
10	HT Industrial	HT	11	5	0.90	HT IA
11	Industrial (Small)	LT	0.415	489	3.42	LT IV
12	Industrial (Medium)					
13	HT Commercial	HT	11	95	27.84	HT 4A, 4B, SPS
14	Applicable to Government Hospitals & Hospitals					
15	Lift Irrigation Schemes/Lift Irrigation Societies					
16	HT Res. Apartments Applicable to all areas					
17	Mixed Load - own consumption					
18	Government offices and department	LT	0.415	255	3.39	
19	HT general	HT	11	22	16.79	HT 2A, 2B
20	Agriculture	LT	0.415	182	0.06	LT V
	Total			42995	169.869	

DIVISION WISE STATUS OF DT LEVEL METERING

The division wise status of DT level metering is given in the table below.

Table 99: Division wise status of DT level metering

a. Division wise status of DT level metering											
Zone name	Circle name	Division name	Feeder name	Total no of DT on feeder	No of unmetred DTs	No of metered DTs			No. of DTs with functional meters		
						AMR metered (communicable)	AMI metered (communicable)	Non-AMR / AMI metered (non-communicable)	Communicating (Total No out of 7 and 8)	Non-communicating (Total No. out of 7,8 and 9)	
1	2	3	4	5= (6+7+8+9)	6	7	8	9	10	11	
TCED	TCED		Ramanilayam	19	9		10		10		
TCED	TCED		Bini	16	6		10		10		
TCED	TCED		Chembukavu	25	5		20		20		
TCED	TCED		Shornur Road	44	15		29		29		
TCED	TCED		East Fort	27	10		17		17		
TCED	TCED		Koorkenchery	23	7		16		16		
TCED	TCED		Veliyanoor	18	9		9		9		
TCED	TCED		Vivekodhayam	21	9		12		12		
TCED	TCED		Arnattukkara	31	16		15		15		
TCED	TCED		DH	34	18		16		16		
TCED	TCED		Kottappuram	39	8		31		31		
TCED	TCED		Vanjikulam	23	8		15		15		
TCED	TCED		M O Road	33	20		13		13		
TCED	TCED		Mission Quarters	31	7		24		24		
TCED	TCED		Paravattani	25	7		18		18		
TCED	TCED		Poonkunam	33	23		10		10		
TCED	TCED		Keralavarma	38	17		21		21		
TCED	TCED		Jubilee Mission	Dedicated feeder							

DETAILS OF DT WISE LOSSES

The details of DT wise losses as per the Performa is given in the table below.

Table 100: DT wise losses

b. Details of DT-wise losses													
Sub-station ID	Feeder ID	Feeder Name	DT Id no	DT Capacity (kVA)	Predominant consumer type of DT (Domestic/Industrial/Agriculture/Mixed)	Type of metering (Unmetered/AMI/AMR/Other)	Status of meter (functional/non-functional)	% of data received automatically (if AMI/AMR)	No. of connected consumers	Input Energy (MU)	Billed Energy (MU)	Loss of Energy (MU)	% Loss
		1	2						3	4	5	6 = 4-5	(7) = [(6)/(4)]*100
Not available as 100% DT metering not done also the DT measurement not yet commenced													

Note: The DT level input energy is not recorded by the DISCOM that results in non-evaluation of DT level losses.

9. FIELD VERIFICATION DATA

ENERGY & POWER QUALITY ANALYSIS - AT SWITCHING STATION

The objective of this section is to establish how the facility is performing in terms of energy consumption and the quality of power at the switching station.

➤ Incomer 110 KV - Measurement Evaluation

The continuous power measurement of incomer feeder (110 kV) conducted using the Krykard ALM 31 power quality analysers. The incomer side was logged for 5 hours and measured data is summarized in the following table. The measurement-averaging period was 20 seconds. The measurement was done on 29th July 2024.

The summary of measured parameters of the transformer is given in the table below.

Table 101: Incomer Measurement Data

Incomer Name		Incomer 110 kV
Date of measurement		29 th July 2024
Basic Parameters		
Parameters	Units	Incomer 110 kV
Voltage line (kV)	Min	112
	Avg	114
	Max	115
Current (A)	Min	64.5
	Avg	77.9
	Max	85.2
Frequency (Hz)	Min	49.8
	Avg	49.97
	Max	50.11
Energy Parameters		
Parameters	Units	Incomer 110 kV
Energy consumed (kWh)	Total	36,355
Energy received (kVAh)	Total	38,084
Power factor		0.95
Active power (kW)	Min	12,385.6
	Avg	14,805.2
	Max	16,168.8
Apparent power (kVA)	Min	13,074.6
	Avg	15,509.5
	Max	16,933.2
Reactive power (kVAr)	Min	3,461.0
	Avg	3,591.6
	Max	3,582.5
Power quality parameters		
Parameters	Units	Incomer 110 kV
Voltage imbalance %	Min	0.1
	Avg	0.2

	Max	0.4
Current imbalance %	Min	1.1
	Avg	1.9
	Max	1.4
THDv %	Min	1.8
	Avg	2.0
	Max	2.8
THDa %	Min	3.3
	Avg	4.0
	Max	0.1

➤ **Electrical Parameters - Profile**

- **Power variations - Incomer**

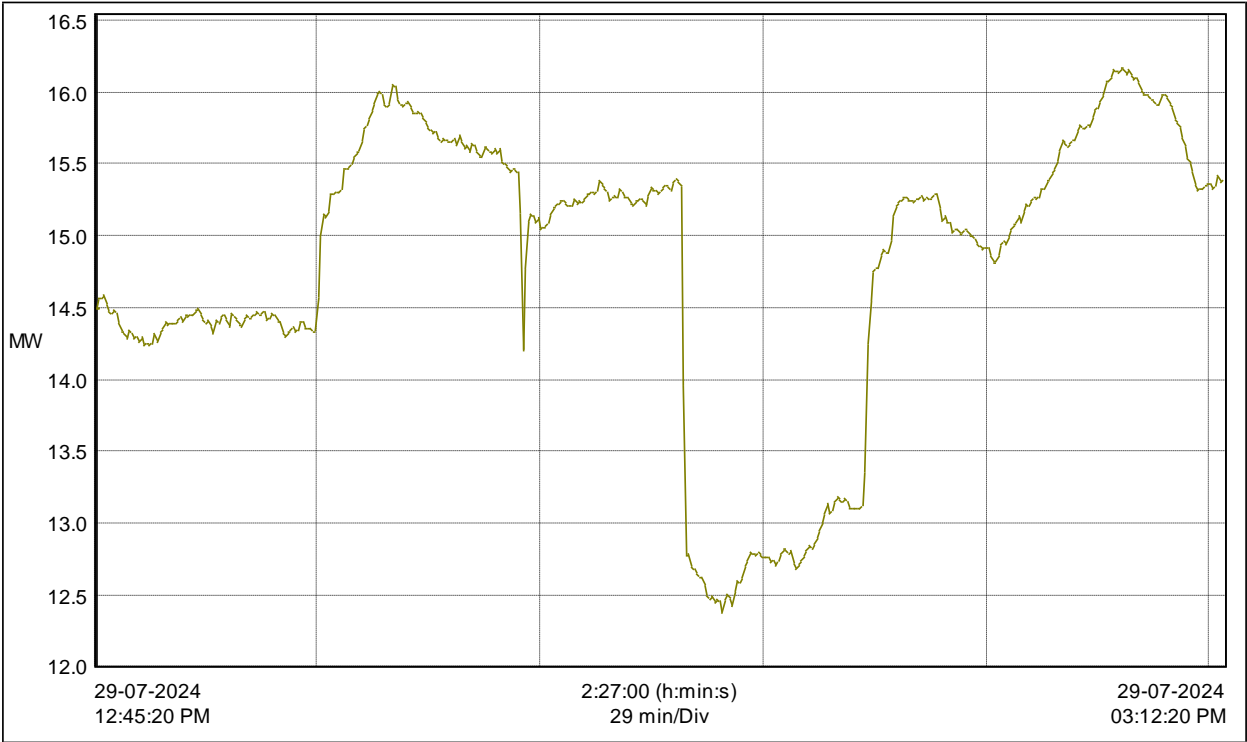

Figure 29: Power variations - continuous logged data

- Demand variations – incomer

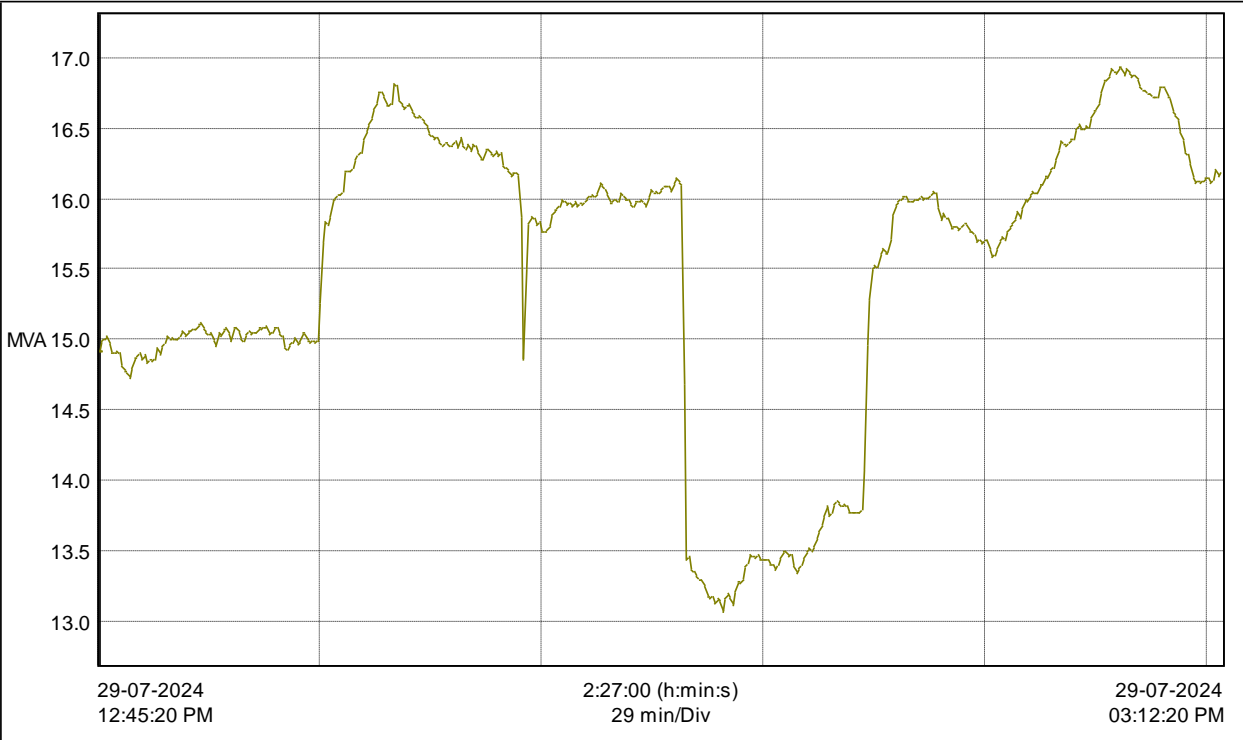

Figure 30: Demand variations – continuous logged data

- Power factor variations - Incomer

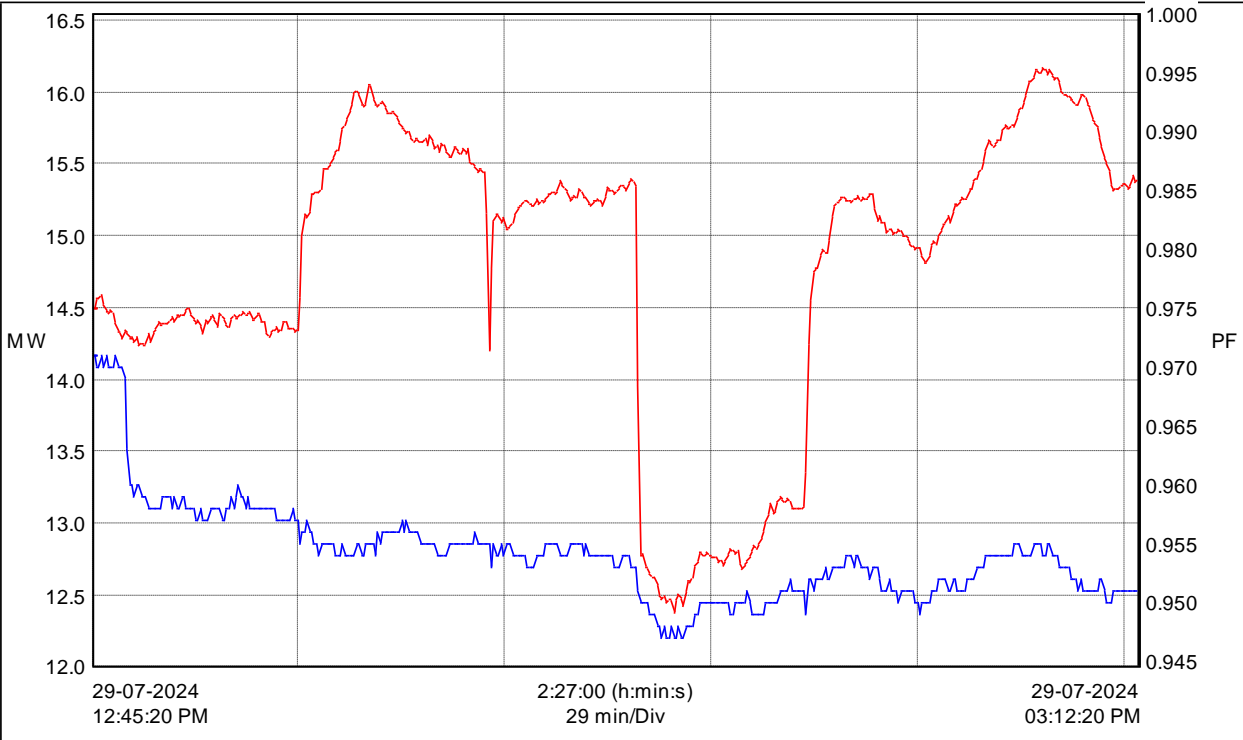

Figure 31: Power factor – variations

➤ Power quality

Harmonics study revolves around the use of non-linear loads that are connected to electric power systems including static power converters, arc discharge devices, saturated magnetic devices and to a lesser degree, rotating machines. Static power converters of electric power are the largest non-linear loads and are used in industry for a variety of purposes such as electro- chemical power supplies, adjustable speed drives, and uninterruptible power supplies.

Classification, effects and standards are given in tables below.

TABLE 102: HARMONICS CLASSIFICATION

	1st order	2nd order	3rd order	3rd order	4th order	5th order	6th order
Frequency Hz	50	100	150	200	250	300	350
Sequence	+	-	0	+	-	0	+

Table 103: CURRENT HARMONICS LIMIT (IEEE 519-2014)

Maximum harmonic current distortion in percent of I_L						
Individual harmonic order (odd harmonics) ^{a, b}						
I_{sc}/I_L	$3 \leq h < 11$	$11 \leq h < 17$	$17 \leq h < 23$	$23 \leq h < 35$	$35 \leq h \leq 50$	TDD
$< 20^c$	4.0	2.0	1.5	0.6	0.3	5.0
$20 < 50$	7.0	3.5	2.5	1.0	0.5	8.0
$50 < 100$	10.0	4.5	4.0	1.5	0.7	12.0
$100 < 1000$	12.0	5.5	5.0	2.0	1.0	15.0
> 1000	15.0	7.0	6.0	2.5	1.4	20.0

^aEven harmonics are limited to 25% of the odd harmonic limits above.

^bCurrent distortions that result in a dc offset, e.g., half-wave converters, are not allowed.

^cAll power generation equipment is limited to these values of current distortion, regardless of actual I_{sc}/I_L , where

I_{sc} = maximum short-circuit current at PCC
 I_L = maximum demand load current (fundamental frequency component) at the PCC under normal load operating conditions

Table 104: VOLTAGE HARMONICS LIMIT (IEEE 519-2014)

Voltage distortion limits		
Bus voltage at PCC	Individual voltage distortion %	Total voltage harmonics distortion %
$V \leq 01$ kV	5.0	8.0
01 kV $< V \leq 69$ kV	3.0	5.0
69.001 kV $< V \leq 161$ kV	1.5	2.5
161.001 kV and above	1.0	1.5

Thus, harmonic limits at the TCED 110 kV incomer is given in the table below:

Table 105: Standard limits as per the IEEE 519-2014 – at TCED incomer

2. Normal range of I_{sc}/I_L at TCED incomer	-	<20
3. Maximum standard Total demand distortion – current	-	5%
4. Maximum standard Total harmonic distortion – voltage	-	2.5%

Harmonic values at the TCED incomer are given in the table below:

Table 106: Harmonics values – TCED incomer

Particulars	THDv max	THDa max	Remarks
	%	%	
Permissible limit	2.5	5	
Incomer 110 kV	2	4	within limits
Incomer 66 kV	NA	NA	Not able to measure

- **Harmonic spectrum**

Voltage harmonic spectrum:

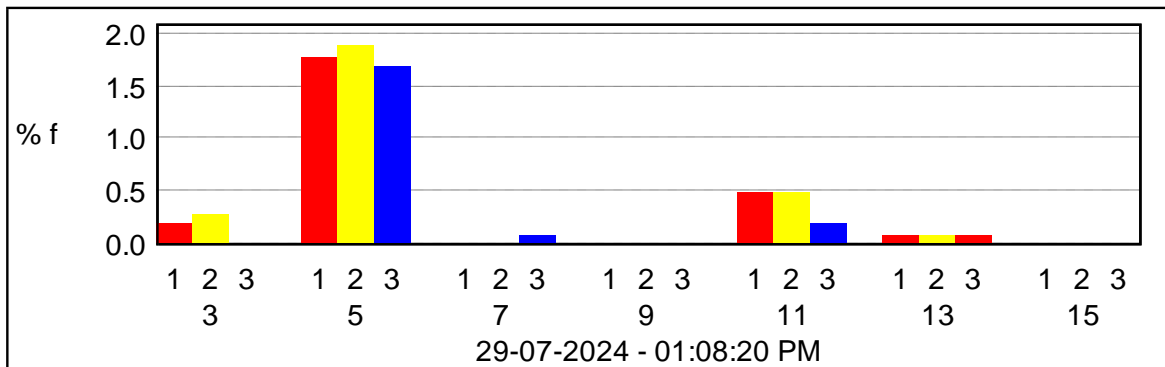

Figure 32: Voltage harmonic spectrum

Current harmonic spectrum:

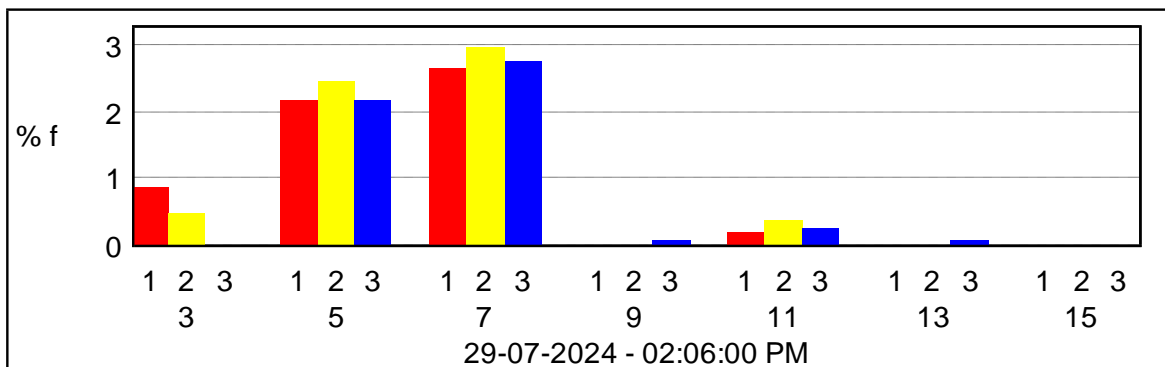

Figure 33: Current harmonic spectrum

OBSERVATIONS AND RECOMMENDATION – ELECTRICAL NETWORK CONFIGURATION

Table 107: Observations & recommendation – electrical network configuration

Observation	Recommendation	Benefit
Incomer measurement evaluation		
<ul style="list-style-type: none"> Real time Demand variation shows that the maximum demand registered at normal period (2:59 pm) and it was 16.93 MVA. The high demand in the normal period is due to the effect of commercial buildings in the DISCOM area, mainly due to the Air conditioning loads in those buildings. 	<ul style="list-style-type: none"> Nil 	<ul style="list-style-type: none"> Nil
Energy & power quality analysis		
<ul style="list-style-type: none"> The measured per day consumption through the 110-kV s/s approx. is 0.356 MU. 	<ul style="list-style-type: none"> The current THD values are within the IEEE 519 standard limit (<5%). The voltage THD values are within the IEEE 519 standard limit (<2.5%) 	<ul style="list-style-type: none"> Nil

PICTURES

General photos



110 KV substation



110 kV substation

10. LIST OF DOCUMENTS VERIFIED WITH EACH PARAMETER

The following are the documents verified during Annual Energy Audit:

Table 108: List of Documents verified

FY 2023-24 Data Verification		
Sl No	Name	Name Supporting Document
Input Energy		
1	Input Energy (MU)	Electricity bill of FY April 2023-March 2024 from KSEBL and Consumer bills
Feeder wise Losses		
2	Feederwise Energy Accounting	TCED software
3	No of connection metered (Nos)	TCED software
4	No of connection Unmetered (Nos)	TCED software
5	Connected Load Metered (MW)	TCED software
6	Connected Load Unmetered (MW)	TCED software
7	Input Energy (MU)	KSEB bill and TCED software for solar export data
8	Metered energy (MU)	TCED software
9	Unmetered energy/Assessment Energy (MU)	TCED software
10	T&D Losses (MU)	Manual calculation
11	Collected Amount	TCED billing software
12	AT&C Loss	TCED software
Details of Input Energy Sources		
13	Generation at Transmission Periphery (Details)	KSEB bill and TCED software for solar export data
14	Embedded Generation in DISCOM Area	TCED software - solar export data

PROFIT & LOSS STATEMENT – FY 2022-23

TCED (From 1 April 2023)			
THRISSUR			
Income & Expenditure Statement			
1-Apr-2023 to 31-Mar-2024			
Particulars	1-Apr-2023 to 31-Mar-2024	Particulars	1-Apr-2023 to 31-Mar-2024
Opening Stock		Sales Accounts	1,51,55,33,318.36
Purchase Accounts	1,33,97,38,280.00	Revenue From Sale of Power	1,51,45,75,668.61
Purchase of Power (Bulk Supply)	1,33,76,15,091.00	Self Consumption Income	9,57,649.75
Solar Ec Arrear(Exp)	48,366.00	Indirect Incomes	2,72,34,819.38
Solar Units Purchased	20,74,823.00	Collection Charges	12,49,125.85
Indirect Expenses	20,74,03,073.19	Interest Income	1,55,06,654.00
Administration & General Charges	2,61,66,497.19	Miscellaneous Income	89,56,006.53
Depreciation Expense	2,63,88,992.00	Penalty Income	6,75,020.00
Employee Cost	12,20,89,616.00	Pole Rental Charges	8,31,475.00
Interest and Finance Charges	2,95,44,663.00	APPLETE AUTHORITY	1,000.00
Repairs & Maintenance	32,13,305.00	Conversion Charges Income	5,631.00
		RENT FROM RMU	9,907.00
		Closing Stock	
		Excess of Expenditure over Income	43,73,215.45
Total	1,54,71,41,353.19	Total	1,54,71,41,353.19

Figure 35: Profit & loss statement

Source: submitted Truing up FY 2023-24

ELECTRICITY BILL - KSEBL - 110 KV INCOMER

KERALA STATE ELECTRICITY BOARD LIMITED

Office of the Special Officer(Revenue), Pattom,Thiruvananthapuram
DEMAND NOTICE FOR APRIL 2024
 (As per CHAPTER VII OF KERALA ELETRICITY SUPPLY CODE -2014)

Con.	1336680002643	Bill Date	04-Apr-2024	Due Date	11-Apr-2024	Bill No	11028111164429 Ver : 0
Tariff	Licensee: Thrissur Corporation	DC Date	26-Apr-2024	CD	62810295	BG	62810295
ASSISTANT SECRETARY, THRISSUR CORPORATION ELECTRICITY DEPARTMENT, CORPORATION OFFICE, THRISSUR, THRISSUR, 680002 Mobile no-9446143072 LCN :21/Thr.Corp				SBI Virtual A/c No(IFS Code:SBIN0070493)-null Consumer GSTIN_ID-32AAAL1623J1Z7/KSEB (L)GST ID=32AAECK227718Z1 TDS u/s 194Q : 75117.17			
Arrears as on 29-Feb-2024				Date of Previous Reading	29-Feb-2024	electricitydepartment@yahoo.co.in	
Disputed	0	Undisputed	0	Date of Present Reading	31-Mar-2024	Supply Voltage	110 kV EHT
Contract Demand(kVA)	75% of CD (KVA)	130% of CD (KVA)	Connected Load (KW)	Average		Billing Type	Non-DPS
0.0	0.0	0.0	0	MD (kVA)	Consumption (kWh)	PF	Section 110 KV Sub Station,Viyur
				20580.00	8710200	0.96	Circle Transmission Circle.
Reading Details of meter X2005320-Working (KVA,KWh,KVAh & KVArh) for 03-2024							
1. Energy Consumption(KWh)				3. Energy Consumption(KVArh) Lag and kVArh (Lead)			
Zone	FR	IR	MF	Units	Zone	FR	IR
1	42597.90	39905.00	2000.000	53858.00	1	12142.1	11361.6
2	14618.90	13646.70	2000.000	19444.00	2	3534.10	3282.40
3	17825.90	16536.10	2000.000	25796.00	3	4434.00	4123.00
			Total	99098.00		Total	kVArh(Lag)
							2686400 kVArh(Lead)
2. Energy Consumption(KVAh)				4. Demand (KVA)			
Zone	FR	IR	MF	Units		Readings	MF
1	44307.10	41502.80	2000.000	56086.00	1	11.52	2000.000
2	15044.00	14039.30	2000.000	20094.00	2	10.21	2000.000
3	18376.00	17049.20	2000.000	26536.00	3	7.81	2000.000
			Total	102716.00	5.Factory Lighting		
					6.Colony Lighting		
					7.Generator		
Ave.PF=KWh/KVAh				0.96			
INVOICE							
	Unit	Rate	Amount (Rs)	Amount			
1	Total Demand Charge			9			
a	Demand Charge	23040.0	400.000	9216000.00	Meter Rent		
b		0.0	400.000	0.00	Central GST Amount@9%		
c		0.0	400.000	0.00	State GST Amount@9%		
d	Excess Demand Charge	0	200.000	0.00	Reconnection Fee		
e			200.000	0.00	Charges for Belated Payments		
f			200.000	0.00	Kerala Flood Cess		
	Sub Total (a+b+c+d+e+f)			9216000.00	Green Energy Charge		
2	Total Energy Charges						
a	Energy charges	99098.00	6.65000	65900170.00			
b			9.97500	0.00			
c			4.98750	0.00			
	Sub Total(a+b+c)			65900170.00			
3	PF Incentive / Disincentive			0.00			
	Total Energy Charge			65900170.00			
4	Energy Charges on Lighting load						
a	Factory Lighting	0	0.1				
b	Colony Lighting	0	0.1	0.00	10.Total(add 1 to 9)		
	Sub Total(a+b)			0.00	Plus/Minus (Round off)		
5	Electricity Duty	65900170	0.100				
6	Ele. Surcharge	9909800	0.025				
7	Duty on self generated energy	0	0.150	0.00	UnDisputed Amt Amount		
8	Penalty for non-segn. of light load						
					Less: 1. Advance / Credit		
					2. CD Interest		
					3. CD/Oth Ref		
					Net Payable		
					75117350.00		
<i>(Rupees Seven Crore Fifty One Lakh Seventeen Thousand Three Hundred Fifty Only)</i>							
E & O E				Balance Advance at Credit, if any			
As per Regulation 130 of Kerala Electricity Supply Code 2014 any complaint regarding accuracy of a bill shall be first taken up with the officer designated to issue the bill (Special Officer(Revenue)). Please follow our official Facebook page fb.com/ksebl for information & announcements.(Please see the instructions overleaf)							
SPECIAL OFFICER (REVENUE)							
<small>Please Detach and enclose with the CD</small>							
1336680002643	11028111164429	Rs.75117350.00		February 2023			
ASSISTANT SECRETARY, THRISSUR CORPORATION							
DD/Payment Instruction	Name of the		Date	Signature			

ELECTRICITY BILL - KSEBL - 66 KV INCOMER

KERALA STATE ELECTRICITY BOARD LIMITED

Office of the Special Officer(Revenue), Pattom,Thiruvananthapuram

DEMAND NOTICE FOR APRIL 2024

(As per CHAPTER VII OF KERALA ELECTRICITY SUPPLY CODE -2014)

Con.	133668002662	Bill Date	04-Apr-2024	Due Date	11-Apr-2024	Bill.No	11028111164428 Ver : 0	
Tariff	Licensee: Thrissur Corporation	DC Date	26-Apr-2024	CD		35836290 BG	35836290	
ASSISTANT SECRETARY, THRISSUR CORPORATION ELECTRICITY DEPARTMENT, CORPORATION OFFICE, THRISSUR, THRISSUR, 680001 Mobile no-9446143072				SBI Virtual A/c No(IFS Code:SBIN0070493)-KSEBHT21C1029 Consumer (GSTIN) ID-32AAALT1623J1277KSEB (LJGST ID=32AAAECK22774B21 TDS u/s 194Q: 54649.94				
LCN :21/1029				Date of Previous Reading 29-Feb-2024 electricitydepartment@yahoo.co.in				
Arrears as on 29-Feb-2024				Date of Present Reading 31-Mar-2024 Supply Voltage 66 kV EHT				
Disputed	0	Undisputed	193914	Average		Billing Type Non-DPS		
Contract Demand(kVA)	75% of CD (KVA)	130% of CD (KVA)	Connected Load (KW)	MD (KVA)	Consumption (kWh)	PF	Section 110 KV Sub Station,Vyyur	
8000.0	6000.0	10400.0	0	15617.70	6467367	0.97	Circle Transmission Circle,	
Reading Details of meter KSEB000021"-Working (KVA,KWh,KVAh & KVArh) for 03-2024								
1. Energy Consumption(KWh)				3. Energy Consumption(KVArh) Lag and kVArh (Lead)				
Zone	FR	IR	MF	Units	Zone	FR	IR	
1	1030721.00	1010223.00	200.000	4099800	1	320667.315333	200.000	
2	335614.00	328979.00	200.000	1327000	2	95069.093530	200.000	
3	455539.00	446731.00	200.000	1761600	3	149218.147213	200.000	
Total				7188200	Total kVArh(Lag) 1777000 kVArh(Lead) 0			
2. Energy Consumption(KVAh)				4. Demand (KVA)				
Zone	FR	IR	MF	Units	1	85.607	200.000	
1	1060412.00	1059220.00	200.000	4238400	2	71.367	200.000	
2	349206.00	342397.00	200.000	1361800	3	53.135	200.000	
3	480561.00	471522.00	200.000	1807800	5.Factory Lighting 0.0			
Total				7408000	6.Colony Lighting 0.0			
Ave PF=KWh/KVAh				0.97	7.Generator 0			
INVOICE								
				Unit	Rate	Amount (Rs)	Amount	
1.Total Demand Charge						6848400.00	9 Other Charges	
a. Demand Charge				17121.0	400.000	6848400.00	Reconnection Fee 0.00	
b.				0.0	400.000	0.00	Charges for Belated Payments 0.00	
c.				0.0	400.000	0.00	Green Energy Charge 0.00	
d. Excess Demand Charge				0	200.000	0.00		
e.				200.000		0.00		
f.				200.000		0.00		
Sub Total (a+b+c+d+e+f)						6848400.00		
2.Total Energy Charges						47801530.00		
a. Energy charges				7188200	6.65000	47801530.00		
b.					9.97500	0.00		
c.					4.98750	0.00		
Sub Total(a+b+c)						47801530.00		
3.PF Incentive / Disincentive						0.00		
Total Energy Charge						47801530.00		
4.Energy Charges on Lighting load								
a. Factory Lighting				0	0.1		10.Total(add 1 to 9)	
b. Colony Lighting				0	0.1	0.00	Plus/Minus (Round off) 0.00	
Sub Total(a+b)							UnDisputed Arr Amount 193914.00	
5.Electricity Duty				47801530	0.100		Less 1. Advance / Credit	
6.Ele. Surcharge				7188200	0.025		2. CD Interest 0.00	
7.Duty on self generated energy				0	0.150	0.00	3. CD/oth Ref 0.00	
8.Penalty for non-segn. of light load							Net Payable 54843844.00	
(Rupees Five Crore Forty Eight Lakh Forty Three Thousand Eight Hundred Forty Four Only)								
E & O E				Balance Advance at Credit, if any				
SPECIAL OFFICER (REVENUE)								
Please Detach and advise with the DC								
133668002662	1102811164428	Rs.54843844.00		February 2023				
ASSISTANT SECRETARY, THRISSUR CORPORATION								
DD/Payment Instruction		Name of the		Date		Signature		

As per Regulation 130 of Kerala Electricity Supply Code 2014 any complaint regarding accuracy of a bill shall be first taken up with the officer designated to issue the bill (Special Officer(Revenue)). Please follow our official Facebook page fb.com/ksebl for information & announcements. (Please see the instructions overleaf)

MONTHLY ENERGY BILL DETAILS - FY 2023-24

Table 109: Energy bill summary – FY 2023-24- 110 kV incomer

CONSUMER	THRISSUR COPRATION ELECTRICITY DEPARTMENT					SUPPLY VOLTAGE		110KV/EHT		CONSUMER NO:		LCN :21/THR.CORP	
	Month	Apr-23	May-23	Jun-23	Jul-23	Aug-23	Sep-23	Oct-23	Nov-23	Dec-23	Jan-24	Feb-24	Mar-24
kVA Normal	23760	26800	21480	18740	22160	18360	18360	22360	19420	18600	20100	23040	
kVA Peak	19800	19740	18960	16680	18380	17080	17380	17980	18180	17140	18540	20420	
kVA Off Peak	15200	15460	13600	11100	12800	12180	11100	11820	11800	11060	13820	15620	
CONTRACT DEMAND CHARGE	902880 0	1018400 0	8162400 0	712120 0	842080 0	6976800 0	6976800 0	8944000 0	7768000 0	7440000 0	8040000 0	9216000 0	98278800
KWH NORMAL	485440 0	4546600 0	5113000 0	444180 0	435660 0	4814000 0	4792000 0	4519600 0	4608400 0	5385800 0	4854400 0	4546600 0	58668600
KWH PEAK	162800 0	1570200 0	1753400 0	153740 0	154900 0	1619000 0	1684000 0	1577000 0	1647800 0	1944400 0	1628000 0	1570200 0	20214800
KWH OFF-PEAK	196360 0	1788200 0	2114800 0	178420 0	181100 0	1885600 0	2000800 0	1806600 0	2061400 0	2579600 0	1963600 0	1788200 0	24837200
TOTAL KWH	844600 0	7905000 0	8981200 0	776340 0	771660 0	8318600 0	8476800 0	7903200 0	8317600 0	9909800 0	8446000 0	7905000 0	10372060 0
KWH CHARGE	548990 00	5138250 0	5837780 0	504621 00	501579 00	5531869 0	5637072 0	5255628 0	5531204 0	6590017 0	54899000 0	5138250 0	68062280 0
PF	0.97	0.97	0.97	0.97	0.97	0.97	0.97	0.97	0.96	0.96	0.97	0.97	
METER RENT	1000	1000	1000	1000	1000	1000	1000	1000	1000	1000	1000	1000	12000
CENTRAL GST	90	90	90	90	90	90	90	90	90	90	90	90	1080
STATE GST	90	90	90	90	90	90	90	90	90	90	90	90	1080
OTHERS	51	81	28	0	0	0	1	1	1	0	51	81	211
GRAND TOTAL	630626 31	5850496 1	6679980 8	574400 80	571358 80	6426387 0	6413990 1	5999746 1	6335322 1	7511735 0	63062631	5850496 1	77891597 1

Table 110: Energy bill summary – FY 2023-24- 66 kV incomer

CONSUMER	THRISSUR COPRATION ELECTRICITY DEPARTMENT				SUPPLY VOLTAGE			66KV/EHT		CONSUMER NO:		LCN :21/1029	
	Apr-23	May-23	Jun-23	Jul-23	Aug-23	Sep-23	Oct-23	Nov-23	Dec-23	Jan-24	Feb-24	Mar-24	Sum
kVA Normal	16742	18112	16261	12974	14749	16107	16610	14837	14636	14740	15763	17121	
kVA Peak	14887	13070	12644	10932	13309	12306	13908	13742	13021	13612	14134	14273	
kVA Off Peak	9697	9232	9713	6840	8726	7903	8909	8537	8233	9211	9110	10627	
CONTRACT DEMAND CHARGE	6361960	6882560	6179180	4930120	5604620	6120660	6311800	5934800	5854400	5896000	6305200	6848400	73229700
KWH NORMAL	3628000	4012600	3364600	3173800	3486800	3302000	3838800	3475000	3756200	3781000	3531000	4099600	43449400
KWH PEAK	1167800	1205800	1049600	996400	1132200	1031000	1203200	1159200	1214800	1251400	1166200	1327000	13904600
KWH OFFPEAK	1578000	1603800	1262200	1143200	1355600	1209800	1418000	1354600	1465000	1550200	1451400	1761600	17153400
TOTAL KWH	6373800.00	6822200.00	5676400.00	5313400.00	5974600.00	5542800.00	6460000.00	5988800.00	6436000.00	6582600.00	6148600.00	7188200.00	74507400
KWH CHARGE	41429700	44344300	36896600	34537100	38834900	36028200	41990000	39825520	42799400	43774290	40888190	47801530	489149730
PF	0.97	0.97	0.97	0.97	0.97	0.97	0.97	0.97	0.97	0.97	0.97	0.97	
OTHERS	41	23	25	39	13	13	23	14	14	10	23	0	238
GRAND TOTAL	47791701	51226883	43075805	39467259	44439533	42148873	48301823	45760334	48653814	49670300	47193413	54649930	562379668

SIGNED PERFORMA

➤ **General information**

General Information			
1	Name of the DISCOM	THRISSUR CORPORATION ELECTRICITY DEPARTMENT (TCED)	
2	ii) Year of Establishment	1937	
	iii) Government/Public/Private	GOVERNMENT	
3	DISCOM's Contact details & Address		
i	City/Town/Village	THRISSUR	
ii	District	THRISSUR	
iii	State	KERALA	Pin 680001
iv	Telephone	0487-2422470	Fax
4	Registered Office		
i	Company's Chief Executive Name	N K KRISHNAKUMAR	
ii	Designation	ASSISTANT SECRETARY	
iii	Address	THRISSUR CORPORATION ELECTRICITY DEPARTMENT, MO ROAD	
iv	City/Town/Village	THRISSUR	P.O. 680001
v	District	THRISSUR	
vi	State	KERALA	Pin 680001
vii	Telephone	0487-2422470	Fax
5	Nodal Officer Details*		
i	Nodal Officer Name (Designated at DISCOM's)	JOSE TS	
ii	Designation	ELECTRICAL ENGINEER	
iii	Address	TCED, THRISSUR CORPORATION ELECTRICITY DEPARTMENT, MO ROAD	
iv	City/Town/Village	THRISSUR	P.O. 680001
v	District	THRISSUR	
vi	State	KERALA	Pin 680001
vii	Telephone	0487-2423559	Fax
6	Energy Manager Details*		
i	Name	B NIKHIL	
ii	Designation	ASSISTANT ENGINEER	Whether EA or EM EA
iii	EA/EM Registration No.	EA-24811	
iv	Telephone	Fax	
v	Mobile	9037192013	E-mail ID psiced.iged@kerala.gov.in
7	Period of Information		
	Year of (FY) information including Date and	01-April 2023 to 31-March-2024	

Assistant Engineer
Electricity Department
Thriassur Corporation



N. K. KRISHNAKUMAR M.A., B.A.
ASSISTANT SECRETARY
ELECTRICITY DEPARTMENT
THRISSUR CORPORATION
M.O. Road, Thriassur
Pin No. 680001
Telephone - 0487 2422470
Mobile - 8921037758
E-mail: electricitydepartment@thriassur.com

➤ Performance Summary of DISCOM – Form-1

Performance Summary of Electricity Distribution Companies			
1	Period of Information Year of (FY) information including Date and Month (Start & End)	01-April 2023 to 31-March-2024	
2	Technical Details		
(a)	Energy Input Details		
(i)	Input Energy Purchase (From Generation Source)	Million kwh	182.078
(ii)	Net input energy (at DISCOM Periphery after adjusting the transmission losses and energy traded)	Million kwh	182.078
(iii)	Total Energy billed (is the Net energy billed, adjusted for energy traded)	Million kwh	169.87
(b)	Transmission and Distribution (T&D) loss Details	Million kwh	12.209
	Collection Efficiency	%	6.71
		%	99.22%
(c)	Aggregate Technical & Commercial Loss	%	7.43%

I/We undertake that the information supplied in this Document and Pro-forma is accurate to the best of my knowledge and if any of the information supplied is found to be incorrect and such information result into loss to the Central Government or State Government or any of the authority under them or any other person affected, I/we undertake to indemnify such loss.

Authorised Signatory and Seal

Name of Authorised Signatory
Name of the DISCOM:
Full Address:-

Signature:-
Name of energy manager: J Nagesh Kumar
AEA 0133
Registration Number:

Apartment, Capital
Nagary, Dehradun
Thiruvananthapuram

Circle for Energy, Government of India
No. 101, 102, 103, 104, 105
New Delhi, 110 002, India
Tel: 011-26101000, 26101001, 26101002, 26101003, 26101004, 26101005, 26101006, 26101007, 26101008, 26101009, 26101010, 26101011, 26101012, 26101013, 26101014, 26101015, 26101016, 26101017, 26101018, 26101019, 26101020, 26101021, 26101022, 26101023, 26101024, 26101025, 26101026, 26101027, 26101028, 26101029, 26101030, 26101031, 26101032, 26101033, 26101034, 26101035, 26101036, 26101037, 26101038, 26101039, 26101040, 26101041, 26101042, 26101043, 26101044, 26101045, 26101046, 26101047, 26101048, 26101049, 26101050, 26101051, 26101052, 26101053, 26101054, 26101055, 26101056, 26101057, 26101058, 26101059, 26101060, 26101061, 26101062, 26101063, 26101064, 26101065, 26101066, 26101067, 26101068, 26101069, 26101070, 26101071, 26101072, 26101073, 26101074, 26101075, 26101076, 26101077, 26101078, 26101079, 26101080, 26101081, 26101082, 26101083, 26101084, 26101085, 26101086, 26101087, 26101088, 26101089, 26101090, 26101091, 26101092, 26101093, 26101094, 26101095, 26101096, 26101097, 26101098, 26101099, 26101100, 26101101, 26101102, 26101103, 26101104, 26101105, 26101106, 26101107, 26101108, 26101109, 26101110, 26101111, 26101112, 26101113, 26101114, 26101115, 26101116, 26101117, 26101118, 26101119, 26101120, 26101121, 26101122, 26101123, 26101124, 26101125, 26101126, 26101127, 26101128, 26101129, 26101130, 26101131, 26101132, 26101133, 26101134, 26101135, 26101136, 26101137, 26101138, 26101139, 26101140, 26101141, 26101142, 26101143, 26101144, 26101145, 26101146, 26101147, 26101148, 26101149, 26101150, 26101151, 26101152, 26101153, 26101154, 26101155, 26101156, 26101157, 26101158, 26101159, 26101160, 26101161, 26101162, 26101163, 26101164, 26101165, 26101166, 26101167, 26101168, 26101169, 26101170, 26101171, 26101172, 26101173, 26101174, 26101175, 26101176, 26101177, 26101178, 26101179, 26101180, 26101181, 26101182, 26101183, 26101184, 26101185, 26101186, 26101187, 26101188, 26101189, 26101190, 26101191, 26101192, 26101193, 26101194, 26101195, 26101196, 26101197, 26101198, 26101199, 26101200, 26101201, 26101202, 26101203, 26101204, 26101205, 26101206, 26101207, 26101208, 26101209, 26101210, 26101211, 26101212, 26101213, 26101214, 26101215, 26101216, 26101217, 26101218, 26101219, 26101220, 26101221, 26101222, 26101223, 26101224, 26101225, 26101226, 26101227, 26101228, 26101229, 26101230, 26101231, 26101232, 26101233, 26101234, 26101235, 26101236, 26101237, 26101238, 26101239, 26101240, 26101241, 26101242, 26101243, 26101244, 26101245, 26101246, 26101247, 26101248, 26101249, 26101250, 26101251, 26101252, 26101253, 26101254, 26101255, 26101256, 26101257, 26101258, 26101259, 26101260, 26101261, 26101262, 26101263, 26101264, 26101265, 26101266, 26101267, 26101268, 26101269, 26101270, 26101271, 26101272, 26101273, 26101274, 26101275, 26101276, 26101277, 26101278, 26101279, 26101280, 26101281, 26101282, 26101283, 26101284, 26101285, 26101286, 26101287, 26101288, 26101289, 26101290, 26101291, 26101292, 26101293, 26101294, 26101295, 26101296, 26101297, 26101298, 26101299, 26101300, 26101301, 26101302, 26101303, 26101304, 26101305, 26101306, 26101307, 26101308, 26101309, 26101310, 26101311, 26101312, 26101313, 26101314, 26101315, 26101316, 26101317, 26101318, 26101319, 26101320, 26101321, 26101322, 26101323, 26101324, 26101325, 26101326, 26101327, 26101328, 26101329, 26101330, 26101331, 26101332, 26101333, 26101334, 26101335, 26101336, 26101337, 26101338, 26101339, 26101340, 26101341, 26101342, 26101343, 26101344, 26101345, 26101346, 26101347, 26101348, 26101349, 26101350, 26101351, 26101352, 26101353, 26101354, 26101355, 26101356, 26101357, 26101358, 26101359, 26101360, 26101361, 26101362, 26101363, 26101364, 26101365, 26101366, 26101367, 26101368, 26101369, 26101370, 26101371, 26101372, 26101373, 26101374, 26101375, 26101376, 26101377, 26101378, 26101379, 26101380, 26101381, 26101382, 26101383, 26101384, 26101385, 26101386, 26101387, 26101388, 26101389, 26101390, 26101391, 26101392, 26101393, 26101394, 26101395, 26101396, 26101397, 26101398, 26101399, 26101400, 26101401, 26101402, 26101403, 26101404, 26101405, 26101406, 26101407, 26101408, 26101409, 26101410, 26101411, 26101412, 26101413, 26101414, 26101415, 26101416, 26101417, 26101418, 26101419, 26101420, 26101421, 26101422, 26101423, 26101424, 26101425, 26101426, 26101427, 26101428, 26101429, 26101430, 26101431, 26101432, 26101433, 26101434, 26101435, 26101436, 26101437, 26101438, 26101439, 26101440, 26101441, 26101442, 26101443, 26101444, 26101445, 26101446, 26101447, 26101448, 26101449, 26101450, 26101451, 26101452, 26101453, 26101454, 26101455, 26101456, 26101457, 26101458, 26101459, 26101460, 26101461, 26101462, 26101463, 26101464, 26101465, 26101466, 26101467, 26101468, 26101469, 26101470, 26101471, 26101472, 26101473, 26101474, 26101475, 26101476, 26101477, 26101478, 26101479, 26101480, 26101481, 26101482, 26101483, 26101484, 26101485, 26101486, 26101487, 26101488, 26101489, 26101490, 26101491, 26101492, 26101493, 26101494, 26101495, 26101496, 26101497, 26101498, 26101499, 26101500, 26101501, 26101502, 26101503, 26101504, 26101505, 26101506, 26101507, 26101508, 26101509, 26101510, 26101511, 26101512, 26101513, 26101514, 26101515, 26101516, 26101517, 26101518, 26101519, 26101520, 26101521, 26101522, 26101523, 26101524, 26101525, 26101526, 26101527, 26101528, 26101529, 26101530, 26101531, 26101532, 26101533, 26101534, 26101535, 26101536, 26101537, 26101538, 26101539, 26101540, 26101541, 26101542, 26101543, 26101544, 26101545, 26101546, 26101547, 26101548, 26101549, 26101550, 26101551, 26101552, 26101553, 26101554, 26101555, 26101556, 26101557, 26101558, 26101559, 26101560, 26101561, 26101562, 26101563, 26101564, 26101565, 26101566, 26101567, 26101568, 26101569, 26101570, 26101571, 26101572, 26101573, 26101574, 26101575, 26101576, 26101577, 26101578, 26101579, 26101580, 26101581, 26101582, 26101583, 26101584, 26101585, 26101586, 26101587, 26101588, 26101589, 26101590, 26101591, 26101592, 26101593, 26101594, 26101595, 26101596, 26101597, 26101598, 26101599, 26101600, 26101601, 26101602, 26101603, 26101604, 26101605, 26101606, 26101607, 26101608, 26101609, 26101610, 26101611, 26101612, 26101613, 26101614, 26101615, 26101616, 26101617, 26101618, 26101619, 26101620, 26101621, 26101622, 26101623, 26101624, 26101625, 26101626, 26101627, 26101628, 26101629, 26101630, 26101631, 26101632, 26101633, 26101634, 26101635, 26101636, 26101637, 26101638, 26101639, 26101640, 26101641, 26101642, 26101643, 26101644, 26101645, 26101646, 26101647, 26101648, 26101649, 26101650, 26101651, 26101652, 26101653, 26101654, 26101655, 26101656, 26101657, 26101658, 26101659, 26101660, 26101661, 26101662, 26101663, 26101664, 26101665, 26101666, 26101667, 26101668, 26101669, 26101670, 26101671, 26101672, 26101673, 26101674, 26101675, 26101676, 26101677, 26101678, 26101679, 26101680, 26101681, 26101682, 26101683, 26101684, 26101685, 26101686, 26101687, 26101688, 26101689, 26101690, 26101691, 26101692, 26101693, 26101694, 26101695, 26101696, 26101697, 26101698, 26101699, 26101700, 26101701, 26101702, 26101703, 26101704, 26101705, 26101706, 26101707, 26101708, 26101709, 26101710, 26101711, 26101712, 26101713, 26101714, 26101715, 26101716, 26101717, 26101718, 26101719, 26101720, 26101721, 26101722, 26101723, 26101724, 26101725, 26101726, 26101727, 26101728, 26101729, 26101730, 26101731, 26101732, 26101733, 26101734, 26101735, 26101736, 26101737, 26101738, 26101739, 26101740, 26101741, 26101742, 26101743, 26101744, 26101745, 26101746, 26101747, 26101748, 26101749, 26101750, 26101751, 26101752, 26101753, 26101754, 26101755, 26101756, 26101757, 26101758, 26101759, 26101760, 26101761, 26101762, 26101763, 26101764, 26101765, 26101766, 26101767, 26101768, 26101769, 26101770, 26101771, 26101772, 26101773, 26101774, 26101775, 26101776, 26101777, 26101778, 26101779, 26101780, 26101781, 26101782, 26101783, 26101784, 26101785, 26101786, 26101787, 26101788, 26101789, 26101790, 26101791, 26101792, 26101793, 26101794, 26101795, 26101796, 26101797, 26101798, 26101799, 26101800, 26101801, 26101802, 26101803, 26101804, 26101805, 26101806, 26101807, 26101808, 26101809, 26101810, 26101811, 26101812, 26101813, 26101814, 26101815, 26101816, 26101817, 26101818, 26101819, 26101820, 26101821, 26101822, 26101823, 26101824, 26101825, 26101826, 26101827, 26101828, 26101829, 26101830, 26101831, 26101832, 26101833, 26101834, 26101835, 26101836, 26101837, 26101838, 26101839, 26101840, 26101841, 26101842, 26101843, 26101844, 26101845, 26101846, 26101847, 26101848, 26101849, 26101850, 26101851, 26101852, 26101853, 26101854, 26101855, 26101856, 26101857, 26101858, 26101859, 26101860, 26101861, 26101862, 26101863, 26101864, 26101865, 26101866, 26101867, 26101868, 26101869, 26101870, 26101871, 26101872, 26101873, 26101874, 26101875, 26101876, 26101877, 26101878, 26101879, 26101880, 26101881, 26101882, 26101883, 26101884, 26101885, 26101886, 26101887, 26101888, 26101889, 26101890, 26101891, 26101892, 26101893, 26101894, 26101895, 26101896, 26101897, 26101898, 26101899, 26101900, 26101901, 26101902, 26101903, 26101904, 26101905, 26101906, 26101907, 26101908, 26101909, 26101910, 26101911, 26101912, 26101913, 26101914, 26101915, 26101916, 26101917, 26101918, 26101919, 26101920, 26101921, 26101922, 26101923, 26101924, 26101925, 26101926, 26101927, 26101928, 26101929, 26101930, 26101931, 26101932, 26101933, 26101934, 26101935, 26101936, 26101937, 26101938, 26101939, 26101940, 26101941, 26101942, 26101943, 26101944, 26101945, 26101946, 26101947, 26101948, 26101949, 26101950, 26101951, 26101952, 26101953, 26101954, 26101955, 26101956, 26101957, 26101958, 26101959, 26101960, 26101961, 26101962, 26101963, 26101964, 26101965, 26101966, 26101967, 26101968, 26101969, 26101970, 26101971, 26101972, 26101973, 26101974, 26101975, 26101976, 26101977, 26101978, 26101979, 26101980, 26101981, 26101982, 26101983, 26101984, 26101985, 26101986, 26101987, 26101988, 26101989, 26101990, 26101991, 26101992, 26101993, 26101994, 26101995, 26101996, 26101997, 26101998, 26101999, 26102000, 26102001, 26102002, 26102003, 26102004, 26102005, 26102006, 26102007, 26102008, 26102009, 26102010, 26102011, 26102012, 26102013, 26102014, 26102015, 26102016, 26102017, 26102018, 26102019, 26102020, 26102021, 26102022, 26102023, 26102024, 26102025, 26102026, 26102027, 26102028, 26102029, 26102030, 26102031, 26102032, 26102033, 26102034, 26102035, 26102036, 26102037, 26102038, 26102039, 26102040, 26102041, 26102042, 26102043, 26102044, 26102045, 26102046, 26102047, 26102048, 26102049, 26102050, 26102051, 26102052, 26102053, 26102054, 26102055, 26102056, 26102057, 26102058, 26102059, 26102060, 26102061, 26102062, 26102063, 26102064, 26102065, 26102066, 26102067, 26102068, 26102069, 26102070, 26102071, 26102072, 26102073, 26102074, 26102075, 26102076, 26102077, 26102078, 26102079, 26102080, 26102081, 26102082, 26102083, 26102084, 26102085, 26102086, 26102087, 26102088, 26102089, 26102090, 26102091, 26102092, 26102093, 26102094, 26102095, 26102096, 26102097, 26102098, 26102099, 26102100, 26102101, 26102102, 26102103, 26102104, 26102105, 26102106, 26102107, 26102108, 26102109, 26102110, 26102111, 26102112, 26102113, 26102114, 26102115, 26102116, 26102117, 26102118, 26102119, 26102120, 26102121, 26102122, 26102123, 26102124, 26102125, 26102126, 26102127, 26102128, 26102129, 26102130, 26102131, 26102132, 2610

➤ Details of Division wise losses

Details of Division Wise Losses (See note below)**																						
Division Wise Losses																						
Period From Apr 2023 to Mar 2024																						
Sl.No	Name of area	Grid code	Name of Division	Consumer profile						Energy parameters				Losses			Commercial Parameters					
				Consumer category	No of connection metered (Nos)	No of connection Un-metered (Nos)	Total Number of connections (Nos)	% of Number of connections	Connected load (MW)	Connected load Unmetered (MW)	Total Connected Load (MW)	% of connected load	Input energy (MWh)	Metered energy (MWh)	Unmetered/Assessment energy (MWh)	Total energy (MWh)	% of energy consumption	T&L loss (MWh)	T&L loss (%)	Billed Amount in Rs. Crore	Collected Amount in Rs. Crore	Collection Efficiency (%)
1	TCED	TCED	TCED	Residential	23383	0	23383	54%	109.31	0	109.307	84.9%	46.60	0	46.60	22.43%			32.61	32.53	99.72%	
				Agricultural	182	0	182	0.42%	0.43	0	0.437	0.2%	9.06	0	9.06	0.05%			0.03	0.03	99.42%	
				Commercial/Industrial-LT	18666	0	18666	40%	89.42	0	89.424	86.7%	71.51	0	71.51	42.10%	12.208	6.71%	54.04	79.24	98.90%	
				Commercial/Industrial-HT	139	0	139	0.31%	43.35	0	43.353	77.8%	50.53	0	50.53	25.75%			54.04	53.70	99.47%	
				Others	325	0	325	0.7%	0.86	0	0.863	0.6%	1.17	0	1.17	0.65%			0.59	0.59	100.00%	
Sub-total				42995	0	42995	100%	243.39	0	243.39	100%	182.078	169.869	0	169.869	100%	12.208	6.71%	167.40	166.30	99.22%	7.43%
2				Residential	0	0	0	0%	0	0	0	0%	0	0	0	0%			0	0	0.00%	
				Agricultural	0	0	0	0%	0	0	0	0%	0	0	0	0%			0	0	0.00%	
				Commercial/Industrial-LT	0	0	0	0%	0	0	0	0%	0	0	0	0%			0	0	0.00%	
				Commercial/Industrial-HT	0	0	0	0%	0	0	0	0%	0	0	0	0%			0	0	0.00%	
				Others	0	0	0	0%	0	0	0	0%	0	0	0	0%			0	0	0.00%	
Sub-total				0	0	0	0%	0	0	0	0%	0	0	0	0%			0	0	0.00%	100%	
76	Total			Residential	23383	0	23383	54.99%	109.31	0	109.308	84.9%	46.60	0	46.60	22.43%			32.63	32.53	99.72%	
				Agricultural	182	0	182	0.42%	0.437	0	0.437	0.2%	9.065	0	9.065	0.05%			0.03	0.03	99.42%	
				Commercial/Industrial-LT	18666	0	18666	44.14%	89.424	0	89.424	86.7%	71.51	0	71.51	42.10%	12.208	6.71%	54.04	79.24	98.90%	
				Commercial/Industrial-HT	139	0	139	0.32%	43.353	0	43.353	77.4%	50.53	0	50.53	25.73%			54.04	53.70	99.37%	
				Others	325	0	325	0.7%	0.863	0	0.863	0.6%	1.17	0	1.17	0.65%			0.59	0.59	100.00%	
77	At company level			42995	0	42995	100%	243.39	0	243.39	100%	182.078	169.869	0	169.869	100%	12.208	6.71%	167.40	166.30	99.22%	7.43%

** Note - It shall be mandatory to record the energy supplied separately for each category of consumers which is being provided a separate rate of subsidy in the tariff, by the state government, so that the subsidy due for the electricity distribution company is quarterly calculated by multiplying the energy supplied to each of such category of consumers by the applicable rate of subsidy notified by the state government.

I/We undertake that the information supplied in this Document and Pro-forma is accurate to the best of my knowledge and if any of the information supplied is found to be incorrect and such information result into loss to the Central Government or State Government or any of the authority under them or any other person affected, I/we undertake to indemnify such loss.

Authorized Signatory and Seal

Name of Authorized Signatory:

Name of the DISCOM:
Full Address:-



J. K. Prasad

M. K. KRISHNAKUMAR M.A., M.Sc.
Assistant Secretary
ELECTRICITY DEPARTMENT
THIRUVANANTHAPURAM MUNICIPAL CORPORATION
6th floor, P.O. No. 743648
Contact Phone - 6457 24224/6
Contact Mobile - 921037768
E-mail: electricdept@tmc.gov.in
tmc@tmc.gov.in

J. M. ...
Assistant Engineer
Electricity Department
Thiruvananthapuram Corporation

Signature:-
Name of Energy Manager: J. Nagesh Kumar
Registration Number: AEA 0133

J. Nagesh Kumar

Center for Energy, Environment and Productivity
Post No. 1330, 50th Street, P.O. Box,
Pondicherry, Tamil Nadu, Chennai - 605 040
Ph: 044 2616 9482, 944488953

J. Nagesh Kumar

➤ Details of infrastructure

Form - Details of Input Infrastructures					
1	Parameters	Total	Covered during in audit	Verified by Auditor in Sample Check	Remarks (Source of data)
i	Number of circles	1	1	1	1
ii	Number of divisions	1	1	1	1
iii	Number of sub-divisions	1	1	1	1
iv	Number of feeders	18	18	16	
v	Number of DTs	490	490	410	16 feeders out of 18
vi	Number of consumers	42995	42995	34282	
2	Parameters	66kV and above	33kV	11/22kV	LT
a.i	Number of conventional metered consumers	-	-	-	8130
ii	Number of consumers with 'smart' meters	-	-	-	-
iii	Number of consumers with 'smart prepaid meters	-	-	-	-
iv	Number of consumers with 'AMR' meters	-	-	-	-
v	Number of consumers with 'non smart prepaid' meters	-	-	139	34726
vi	Number of unmetered consumers	-	-	-	-
vii	Number of total consumers	-	-	139	42856
b.i	Number of conventionally metered Distribution Transformers	-	-	-	286
ii	Number of DTs with communicable meters	-	-	-	-
iii	Number of unmetered DTs	-	-	-	194
iv	Number of total Transformers	-	-	-	480
c.i	Number of metered feeders	-	-	-	-
ii	Number of feeders with communicable meters	-	-	18	-
iii	Number of unmetered feeders	-	-	-	-
iv	Number of total feeders	-	-	18	-
d	Line length (ct km)	-	4.2	179.956	287.953
e	Length of Aerial Bunched Cables	-	-	1.85	-
f	Length of Underground Cables	-	2.565	71.83	4.525
3	Voltage level	Particulars	MU	Reference	Remarks (Source of data)
i	66kV and above	Long Term Conventional	178.228	Includes input energy for franchisees	
		Medium Conventional	0		
		Short Term Conventional	0		
		Banking	0		
		Long-Term Renewable energy	0.000		
		Medium and Short Term RE	0		
		Captive, open access input	0		
		Sale of surplus power	0		
		Quantum of inter-state transmission loss	0		
		Power procured from inter-state sources	178.228		
Power at state transmission boundary	178.228				
iii		Input in DISCOM wires network	178.228		
v	11 kV	Renewable Energy Procurement	0.549	Self generation = solar power plant in own buildings + 11 kV export received	
		Small capacity conventional/ biomass/ hydro plants	0.00		
		Sales Migration Input	0.00		

vi		Renewable Energy Procurement	3.31	Total LT export	
	LT	Sales Migration input	0		
vii		Energy Embedded within DISCOM wires network	3.85		
viii		Total Energy Available/ Input	182.078		
4	Voltage level	Energy Sales Particulars	MU	Reference	
i	LT Level	DISCOM consumers	119.34	Include sales to consumers in franchisee areas, unmetered consumers	Total LT Sales
		Demand from open access, captive	0.00		
		Embedded generation used at LT level	3.310	Demand from embedded generation at LT level	
		Sale at LT level	119.34		
		Quantum of LT level losses	12.15	Included the LT OH line length, LT cable, Switch gear & Commercial losses	Manually calculated using distribution line length and feeder wise
ii	11 kV Level	Energy Input at LT level	131.48		
		DISCOM consumers	50.53	Include sales to consumers in franchisee areas, unmetered consumers	
		Demand from open access, captive	0.00	Non DISCOM's sales	
		Embedded generation at 11 kV level used	0.54	Demand from embedded generation at 11kV	
		Sales at 11 kV level	50.53		
		Quantum of Losses at 11 kV	0.06	HTT + HT losses	distribution line length and feeder wise consumption
		Energy input at 11 kV level	50.60		
		Total Energy Requirement	182.078		
		Total Energy Sales	169.869		
Energy Accounting Summary					
5	DISCOM	Input (in MU)	Safe (in MU)	Loss (in MU)	Loss %
i	LT	131.48	119.34	12.147	9.24
ii	11 Kv	50.596	50.533	0.063	0.12
iii	33 kv				
iv	> 33 kv				
Loss Estimation for DISCOM					
	T&D loss (MU)	12.209			
	D loss (MU)	12.209			
	T&D loss (%)	6.71			
	D loss (%)	6.71			



[Handwritten Signature]

ASSTANT SECRETARY
ELECTRICITY DEPARTMENT
MUNICIPAL CORPORATION
THIRUVANANTHAPURAM
Kerala
Phone: 0471-2323470
Mobile: 9847103720

[Handwritten Signature]
Assistant Engineer
Electricity Department
Thiruvananthapuram Corporation

[Handwritten Signature]

Energy Department
P.O. No. 105, 106 Street, 11 Block,
P.O. Box, Anna Nagar, Chennai - 600 042.
Tel: 54 518 362, 54422702

➤ Form input energy

Form input energy (Date of input energy & instrument)													
A. Secondary energy sources & transmission													
Sl. No.	Description										Period From APR 2023 to Month 2024	Value	Unit
A.1	Input Energy purchased from:										112.478		
A.2	Transmission loss (%)										0		
A.3	Transmission loss (kWh)										0		
A.4	Energy purchased from generator (kWh)										0.05		
A.5	Other energy source (kWh)										0		
A.6	Total kWh										112.528		
A.7	Net input energy (measured as kWh) per kWh or at distribution substation (kWh)										112.528		Local net input
A.8	A kWh metering available as per IS 146 for use or not from IS 146										Yes		
A.9	A kWh metering available as IS 146 for use or not from IS 146										Yes		
A.10	No. of metering available at 11										59.306		2% out of 400 transformers
A.11	No. of metering available at 220										126		
A.12	No. of meters at 66KV or above level										0		
A.13	No. of meters at 33KV or above level										0		
A.14	No. of meters at 11KV or above level										28		not available
A.15	No. of 11KV meters										0		
A.16	Line length (km. km) at 66KV voltage level										0		
A.17	Line length (km. km) at 33KV voltage level										0.2		Measured through HT line mapping
A.18	Line length (km. km) at 11KV voltage level										179.156		Measured through HT line mapping
A.19	Line length (km) at 11KV level										287.913		Measured through HT line mapping
A.20	Length of Parallel Bundled Cables										1.85		Measured through HT line mapping
A.21	Length of Underground Cables										78.92		Site measurement
A.22	Total kWh										112.528		

B. Metering of input energy at location power													
Sl. No.	Line	CT	Transformer	Instrument	Location	Instrument	Instrument	Instrument	Instrument	Instrument	Instrument	Instrument	Instrument
B.1	T-100	1000	110	110	110	110	110	110	110	110	110	110	110
B.2	T-100	1000	110	110	110	110	110	110	110	110	110	110	110
B.3	T-100	1000	110	110	110	110	110	110	110	110	110	110	110
B.4	T-100	1000	110	110	110	110	110	110	110	110	110	110	110
B.101	Total kWh										112.528	0.05	112.578

I/We undertake that the information supplied in this Document and Form is accurate to the best of my knowledge and if any of the information supplied is found to be incorrect and such information results in loss to the Central Government or State Government or any of the authority under them or any other person affected, I/we undertake to indemnify such loss.

Authorized Signatory and Seal:

Name of Authorized Signatory: *Assistant Engineer*
 Name of the Division: *Electricity Department*
 Full Address: *Thiruvananthapuram Corporation*
 Seal:

Name of Energy Consumer: *[Signature]*
 Registration Number: *[Signature]*
 Date of Entry into Service of Meters: *[Signature]*
 Meter No. / Meter Class: *[Signature]*
 Meter Location: *[Signature]*

[Signature]
 Assistant Secretary
 Electricity Department
 Thiruvananthapuram Corporation
 Thiruvananthapuram
 Phone No. 743643
 Mobile No. 9447 222470
 Email: electricitydepartment@tceco.nic.in
 02/10/2024

➤ Details of input energy sources

Details of Input Energy Sources												
Project Period: 01st April 2022 to Mar 2022												
A. Generation of Electricity (Details)												
S.No.	Name of Generation Station	Generating Capacity (MW)	Type of Fuels (Diesel, Coal, Gas, Biomass, Solar, Wind, etc.)	Type of Plant (CCGT, Steam, etc.)	Type of Contract (PPA, etc.)	Value of Input (₹/kWh)	Cost of Input (₹/kWh)	Value of Output (₹/kWh)	Efficiency (%)	Remarks	Source of Data	Remarks
1	MIL											
2												
B. Electrical Generation in DISCOM Area												
S.No.	Name of Generation Station	Generating Capacity (MW)	Type of Fuels (Diesel, Coal, Gas, Biomass, Solar, Wind, etc.)	Type of Plant (CCGT, Steam, etc.)	Value of Input (₹/kWh)	Cost of Input (₹/kWh)	Value of Output (₹/kWh)	Efficiency (%)	Remarks	Source of Data	Remarks	
1	Coal generation	1.0	Coal	Net metering	Renewable Source	0.1	0.1	0.1				
2	From consumers	2.85	Renewable	Net metering	Renewable Source	0.11	0.11	0.11				Manual measurement - Field sheet

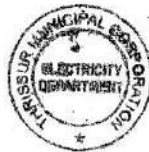

Assistant Engineer
Electricity Department
Thiruvananthapuram Corporation

J. M. ...
Date for Energy, End-use and Feasibility
Audit No. 1006/2022 dated 14/03/2022
Postal Colony, Anna Nagar, Chennai - 600 042
Ph: 044 25 2622, 044850703

M. K. ...

Mr. M. K. KRISHNAMOORTHY M. K. KRISHNAMOORTHY M.A., I.E.E.
Assistant Secretary
Electricity Department
Thiruvananthapuram Corporation
Address: ...
Contact No: 743648
Mobile No: 9447 242247
E-mail: ...
Tel: 242247

01/03/22
Electrical Engineer
Electricity Department
Thiruvananthapuram Corporation
Tel: 242247

➤ Details of consumers and consumption

Period From APR 2023 to MAR 2024						
S.No	Type of Consumers	Category of Consumers (HT/HT/LT/Others)	Voltage Level (kV)	No of Consumers	Total Consumption (in MU)	Remarks (Source of data)
1	Domestic	LT	0.415	29363	46.60	
2	Commercial	LT	0.415	18222	64.89	
3	IP Sels					
4	For. & Nur. & Coffea/Tea & Rubber (Metered)					
5	For. & Nur. & Coffea/Tea & Rubber (Flat)					
6	Heating and Motive Power					
7	Water Supply					
8	Public Lighting	LT	0.415	325	1.17	VIII B
9	HT Water Supply					
10	HT Industrial	HT	11	5	0.90	HT IA
11	Industrial (Small)	LT	0.415	489	3.42	LT IV
12	Industrial (Medium)					
13	HT Commercial	HT	11	65	27.84	HT 4A,43,SPS
14	Applicable to Government Hospitals & Hospitals					
15	Lift Irrigation Schemes/Lift Irrigation Societies					
16	HT Res. Apartments Applicable to all areas					
17	Mixed Load - own consumption					
18	Government offices and department	LT	0.415	255	3.39	
19	L.T. general	HT	11	22	16.79	HT 2A,2B
20	Agriculture	LT	0.415	182	0.06	LT V
21	Government offices and department	HT	11	17	5.00	
22	Others-3 (if any, specify in remarks)					
23	Others-5 (if any, specify in remarks)					
24						
25						
				Total	42955	169.865

[Handwritten initials]

Assistant Engineer
Electricity Department
Tirissur Corporation

[Handwritten signature]

Deputy for Energy, Environmental and Productivity
Post No. 1038, 200, 2nd, 11-11-14,
Pondicherry, Anna Nagar, Chennai - 600 046.
PH : 044 2666 3683, 2666292533

[Handwritten initials]

[Handwritten signature]

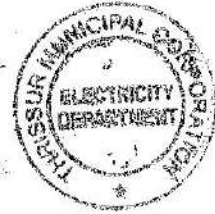

Mr. N. K. KRISHNAKUMAR M.A., P.U.C.
ASSISTANT SECRETARY
ELECTRICITY DEPARTMENT
TIRISSUR CORPORATION
Office Phone No: 743548
Office Phone - 0487 2422470
Office Mobile - 982 1937758
Email: electricitydepartment@tchen.co.in
Tirissur, 689 001

➤ Details of Feeder wise losses

a. Division wise status of DT level metering										
Zone name	Circle name	Division name	Feeder name	Total no of DT on feeder	No of unmetered DTs	No of metered DTs			No. of DTs with functional meters	
						AMR metered (communicable)	AMI metered (communicable)	Non-AMR/AMI metered (non-communicable)	Communicating (Total No out of 7 and 8)	Non-communicating (Total No out of 7,8 and 9)
1	2	3	4	5=(6+7+8+9)	6	7	8	9	10	11
TCED	TCED		Ramanlayam	19	9	9	10		10	
TCED	TCED		Biri	16	6		10		10	
TCED	TCED		Chembukavu	25	5		20		20	
TCED	TCED		Shernur Road	44	15		29		29	
TCED	TCED		East Fort	27	10		17		17	
TCED	TCED		Koorkenchery	23	7		16		16	
TCED	TCED		Veliyanoor	18	9		9		9	
TCED	TCED		Vivekodayam	21	9		12		12	
TCED	TCED		Arnattukkara	31	16		15		15	
TCED	TCED		DH	34	18		16		16	
TCED	TCED		Kottappuram	39	8		31		31	
TCED	TCED		Vanjikulam	23	8		15		15	
TCED	TCED		M O Road	33	20		13		13	
TCED	TCED		Mission Quarters	31	7		24		24	
TCED	TCED		Paravattani	25	7		18		18	
TCED	TCED		Poonkunam	33	23		10		10	
TCED	TCED		Keralavarma	38	17		21		21	
TCED	TCED		Jubilee Mission	Dedicated feeder	Dedicated feeder					

b. Details of DT wise losses													
Sub station ID	Feeder ID	Feeder Name	DT ID no	DT Capacity (kVA)	Predominant consumer type of DT (Domestic/Industrial/Agriculture/Mixed)	Type of metering (Unmetered/AMI/AMR/Other)	Status of meter (functional/non-functional)	% of data received automatically (if AMI/AMR)	No. of connected consumers	Input Energy (MU)	Billed Energy (MU)	Loss of Energy (MU)	% Loss
1	2	3	4	5	6	7	8	9	10	11	12	13	14
Not available as 100% DT metering not done also the DT measurement not yet commenced													(7) = $\frac{(12)-(11)}{(10)} \times 100$



[Handwritten Signature]

[Handwritten Signature]

[Handwritten Signature]
Assistant Engineer,
Electricity Department,
Urban Corporation

[Handwritten Signature]

Mr. N. K. KRISHNANWAR M.A., I.L.D.
Assistant Revenue Officer
ELECTRICITY DEPARTMENT
TAMIL NADU MUNICIPAL CORPORATION
Chennai-600 002
Phone - 287 242470
Fax - 287 242470

Date of this statement as provided
10th Jul 2019
Prepared by: Mr. N. K. KRISHNANWAR
in presence of: Mr. N. K. KRISHNANWAR

10th Jul 2019
Electricity Department
Urban Corporation
Chennai-600 002

➤ Details of Subsidy

Consumer category (Separate for each subsidized consumer category)	Billed energy			Subsidized billed energy			Applicable rate of subsidy as notified by state govt		Subsidy due from state govt			Subsidy actually billed/claimed from state govt (as against col 12)	Subsidy received from state govt (As against col 13)	Balance subsidy yet to be received from state govt
	(in kWh)			(in kWh)			(in Rs/kWh)		(in Rs Cr)			(in Rs Cr)	(in Rs Cr)	(in Rs Cr)
	Metered	Unmetered	Total	Metered (out of col 2)	Unmetered* (out of col 3)	Total	Metered energy	Unmetered energy	Metered energy	Unmetered energy	Total			
1	2	3	4 = 2+3	5	6	7 = 4*6	8	9	10 = 5*8	11 = 6*9	12 = 10 + 11	13	14	15 = 13 + 14
Residential	46597667	0	46597667	0	0	0	0	0	0	0	0	0	0	0
Agricultural	55321	0	55321	0	0	0	0	0	0	0	0	0	0	0
Commercial/Industrial-LT	71512412	0	71512412	0	0	0	0	0	0	0	0	0	0	0
Commercial/Industrial-HT	50532779	0	50532779	0	0	0	0	0	0	0	0	0	0	0
Others + own consumption	1170525	0	1170525	0	0	0	0	0	0	0	0	0	0	0
Total	169868704		169868704											
*Basis of assessment of energy to be provided in the notes along with relevant Government Orders														
** Provide copy of relevant work orders														
NO SUBSIDY IN TCED														



[Handwritten Signature]

M. K. KRISHNAN NARAYANAN
 ASSISTANT SECRETARY
 ELECTRICITY DEPARTMENT
 THIRUVANANTHAPURAM MUNICIPAL CORPORATION
 Thiruvananthapuram
 Telephone - 0477 2422479
 Fax - 0477 2422479
 Email - mkrishnan@tmc.gov.in

[Handwritten Signature]

Office for Energy, Environment and Productivity
 Plot No. 8030, 80th Street, P. O. Box,
 Panchi Colony, Anna Nagar, Chennai - 600 086
 Ph: 044 2616 0483, 044 2616 0422

[Handwritten Signature]
 Assistant Engineer -
 Electricity Department
 Thiruvananthapuram Corporation

[Handwritten Signature]

➤ Details of DT level losses

a. Division wise status of DT level metering										
Zone name	Circle name	Division name	Feeder name	Total no of DT on feeder	No of unmetered DTs	No of metered DTs			No. of DTs with functional meters	
						AMR metered (communicable)	AMI metered (communicable)	Non-AMR / AMI metered (non-communicable)	Communicating (Total No out of 7 and 8)	Non-communicating (Total No. out of 7,8 and 9)
1	2	3	4	5=(6+7+8+9)	6	7	8	9	10	11
TCED	TCED		Ramanilayam	19		9		10		10
TCED	TCED		Bini	16		6		10		10
TCED	TCED		Chembukavu	25		5		20		20
TCED	TCED		Shornur Road	44		15		29		29
TCED	TCED		East Fort	27		10		17		17
TCED	TCED		Koorkechay	23		7		16		16
TCED	TCED		Veliyanoor	18		9		9		9
TCED	TCED		Vivekodayam	21		9		12		12
TCED	TCED		Arnattukkara	31		16		15		15
TCED	TCED		DH	34		18		16		16
TCED	TCED		Kottappuram	39		8		31		31
TCED	TCED		Vanjikulam	23		8		15		15
TCED	TCED		M O Road	33		20		13		13
TCED	TCED		Mission Quarters	31		7		24		24
TCED	TCED		Paravattam	25		7		18		18
TCED	TCED		Poonkunam	33		23		10		10
TCED	TCED		Keralavarma	38		17		21		21
TCED	TCED		Jubilee Mission	Dedicated feeder	Dedicated feeder					

b. Details of DT-wise losses													
Sub-station ID	Feeder ID	Feeder Name	DT Id no	DT Capacity (KVA)	Predominant consumer type of DT (Domestic/Industrial/Agriculture/Mixed)	Type of metering (Unmetered/AMI/AMR/Other)	Status of meter (functional/non-functional)	% of data received automatically (if AMI/AMR)	No. of connected consumers	Input Energy (MU)	Billed Energy (MU)	Loss of Energy (MU)	% Loss
		1	2						3	4	5	6 = 4-5	(7) = [(6)/(4)] *100
Not available as 100% DT metering not done also the DT measurement not yet commenced													



[Signature]
 M. R. KRISHNANUMAR M.A., I.L.M.
 J.P. DIVISION ASSISTANT SECRETARY
 J.P. DIVISION ELECTRICITY DEPARTMENT
 THIRUVANANTHAPURAM CORPORATION
 Contact No: 243248
 Mobile No: 9447247288
 Email: mkrishna@thiruvananthapuram.tn.nic.in

[Signature]
 J. M. S.
 Jt. Secy, Thiruvananthapuram
 10th Fl, 2nd Stage, 2nd Cross
 Thiruvananthapuram - 695 012

[Signature]
 Assistant Engineer
 Electricity Department
 Thiruvananthapuram

[Signature]
 J. M. S.
 Jt. Secy, Thiruvananthapuram
 10th Fl, 2nd Stage, 2nd Cross
 Thiruvananthapuram - 695 012

12. ABBREVIATIONS

ABR	:	Average billing rate	UG	:	Underground
ACSR	:	Aluminium core steel reinforced	UPS	:	Uninterruptible power supply
APFC	:	Automatic Power Factor controller	VFD	:	Variable frequency drive
AVG	:	Average			
BD	:	Billing demand			
BDV	:	Breakdown voltage			
BEE	:	Bureau of energy efficiency			
CEA	:	Central electrical authority			
CFL	:	Compact fluorescent lamp			
CFM	:	Feet cube per minute			
CT	:	Current transformer			
DB	:	Distribution Board			
DC	:	Designated consumer			
DT	:	Distribution transformer			
EC	:	Energy Conservation			
FD	:	Forced draft			
HPSV	:	High pressure sodium vapour			
HT	:	High Tension			
IEC	:	International electro technical commission			
IEEE	:	The Institute of electrical and electronics engineers			
IS	:	Indian Standard			
KG	:	Kilo gram			
KSEB	:	Kerala state electricity board			
KVA	:	Kilo Volt Ampere			
KVAH	:	Kilo volt Ampere Hour			
KVAR	:	Kilo volt ampere			
KW	:	Kilo Watts			
KWH	:	Kilo watt hour			
LED	:	Light emitting diode			
LT	:	Low tension			
MAX	:	Maximum			
MH	:	Metal halide			
MU	:	Million units			
MVA	:	Mega volt ampere			
MW	:	Mega watt			
NEMA	:	National Electrical Manufacturers Association			
ONAN	:	Oil natural air natural			
PCC	:	Point of common coupling			
PF	:	Power factor			
PSI	:	Pound square inch			
PT	:	Protentional transformer			
R/km	:	Resistance per kilometre			
RMD	:	Registered Maximum demand			
SDA	:	State designated agency			
SEC	:	Specific electricity consumption			
SFU	:	Switch Fuse Unit			
SLD	:	Single Line Diagram			
TDD	:	Total demand distortion			
THD	:	Total harmonics distortion			
TOD	:	Time of day			
TOE	:	Tonne of oil equivalent			
TPEA	:	Third party energy auditor			